

**Ranger II™ Storm Series®**  
**Wheelchairs**  
**MWD/FWD**

**Ranger II<sub>BASIC</sub>**  
**Ranger II<sub>STANDARD</sub>**  
**Ranger II<sub>JR</sub>**  
**Ranger II<sub>250 SERIES</sub>**

DEALER: THIS MANUAL MUST BE GIVEN TO THE USER OF  
THE WHEELCHAIR.

USER: BEFORE USING THIS WHEELCHAIR, READ THIS  
MANUAL AND SAVE FOR FUTURE REFERENCE.



**Yes, you can.™**

**WARNING**

**DO NOT OPERATE THIS EQUIPMENT WITHOUT FIRST READING AND UNDERSTANDING THIS MANUAL. IF YOU ARE UNABLE TO UNDERSTAND THE WARNINGS, CAUTIONS, AND INSTRUCTIONS, CONTACT A HEALTHCARE PROFESSIONAL, DEALER OR TECHNICAL PERSONNEL IF APPLICABLE BEFORE ATTEMPTING TO USE THIS EQUIPMENT - OTHERWISE INJURY OR DAMAGE MAY RESULT.**

**THE INITIAL SET UP OF THIS WHEELCHAIR MUST BE PERFORMED BY A QUALIFIED TECHNICIAN.**

**PROCEDURES OTHER THAN THOSE DESCRIBED IN THIS MANUAL MUST BE PERFORMED BY A QUALIFIED TECHNICIAN.**

**SPECIAL NOTES**

WARNING/CAUTION notices as used in this manual apply to hazards or unsafe practices which could result in personal injury or property damage.

**NOTICE**

THE INFORMATION CONTAINED IN THIS DOCUMENT IS SUBJECT TO CHANGE WITHOUT NOTICE.

**WHEELCHAIR USER**

As a manufacturer of wheelchairs, Invacare endeavors to supply a wide variety of wheelchairs to meet many needs of the user. However, final selection of the type of wheelchair to be used by an individual rests solely with the user and his/her healthcare professional capable of making such a selection.

**WHEELCHAIR TIE-DOWN RESTRAINTS AND SEAT POSITIONING STRAPS**

Invacare recommends that wheelchair users NOT be transported in vehicles of any kind while in wheelchairs. As of this date, the Department of Transportation has not approved any tie-down systems for transportation of a user while in a wheelchair, in a moving vehicle of any type.

It is Invacare's position that users of wheelchairs should be transferred into appropriate seating in vehicles for transportation and use be made of the restraints made available by the auto industry. Invacare cannot and does not recommend any wheelchair transportation systems.

**AS REGARDS RESTRAINTS - SEAT POSITIONING STRAPS - IT IS THE OBLIGATION OF THE DME DEALER, THERAPISTS AND OTHER HEALTHCARE PROFESSIONALS TO DETERMINE IF A SEAT POSITIONING STRAP IS REQUIRED TO ENSURE THE SAFE OPERATION OF THIS EQUIPMENT BY THE USER. SERIOUS INJURY CAN OCCUR IN THE EVENT OF A FALL FROM A WHEELCHAIR.**

**SAVE THESE INSTRUCTIONS**

# TABLE OF CONTENTS

The following procedures refer to RANGER II MWD - RANGER II<sub>BASIC</sub>, RANGER II<sub>STANDARD</sub> and RANGER II<sub>250 SERIES</sub> RANGER II FWD - RANGER II<sub>BASIC</sub> and RANGER II<sub>STANDARD</sub> and RANGER II<sub>250 Series</sub>\*

<b>SPECIAL NOTES</b> .....	<b>2</b>	REPOSITIONING BATTERY CHARGER CONNECTOR .....	32
<b>SPECIFICATIONS</b> .....	<b>4</b>	FUSE REPLACEMENT .....	33
<b>PROCEDURE 1 - GENERAL GUIDELINES</b> .....	<b>7</b>	<b>PROCEDURE 7 - RETAINING STRAP</b> .....	<b>34</b>
REPAIR OR SERVICE INFORMATION .....	7	REPLACING BATTERY BOX RETAINING STRAP .....	34
OPERATING INFORMATION .....	7	<b>PROCEDURE 8 - WHEELS</b> .....	<b>36</b>
SAFETY/HANDLING OF WHEELCHAIRS .....	9	ENGAGING/DISENGAGING MOTORS WITH CLUTCHES .....	36
WARNING/CAUTION LABEL LOCATION .....	14	ENGAGING/DISENGAGING MOTORS WITH MOTOR LOCKS .....	36
<b>PROCEDURE 2 - SAFETY INSPECTION CHECKLIST/TROUBLESHOOTING</b> .....	<b>18</b>	ADJUSTING FORKS .....	37
SAFETY INSPECTION CHECKLIST .....	20	<b>PROCEDURE 9 - SHROUDS</b> .....	<b>38</b>
TROUBLESHOOTING GUIDE - MECHANICAL ..	18	REMOVING/INSTALLING SHROUDS .....	38
TROUBLESHOOTING GUIDE - ELECTRICAL ...	18	<b>PROCEDURE 10 - BATTERIES</b> .....	<b>42</b>
CHECKING BATTERY CHARGE LEVEL .....	18	INSTALLING/REMOVING BATTERIES INTO/FROM BATTERY BOXES .....	42
<b>PROCEDURE 3 - FRONT RIGGINGS</b> .....	<b>21</b>	CONNECTING BATTERY CABLES .....	43
INSTALLING/REMOVING FOOTRESTS .....	21	<b>PROCEDURE 11 - FWD WHEELCHAIRS</b> .....	<b>47</b>
ADJUSTING FOOTREST HEIGHT .....	21	TRANSPORTING RANGER II FWD .....	47
REPLACING HEEL LOOPS .....	22	WHEN TO CHARGE BATTERIES .....	48
INSTALLING/REMOVING ELEVATING LEGRESTS .....	22	CHARGING BATTERIES .....	49
RAISING/LOWERING ELEVATING LEGRESTS AND/OR ADJUSTING CALFPADS .....	23	REPLACING BATTERIES .....	49
ADJUSTING/REPLACING TELESCOPING FRONT RIGGING SUPPORT .....	23	INSTALLING/REMOVING BATTERY BOXES ...	50
ADJUSTING REMOVABLE FOOTBOARD .....	24	BATTERY TRAY .....	52
PREPARING REMOVEABLE FOOTBOARD FOR WHEELCHAIR TRANSPORTATION .....	26	<b>PROCEDURE 12 - MWD WHEELCHAIRS</b> .....	<b>54</b>
<b>PROCEDURE 4 - ARMS</b> .....	<b>27</b>	TRANSPORTING RANGER II MWD .....	54
INSTALLING/REMOVING FLIP BACK ARMRESTS .....	27	WHEN TO CHARGE BATTERIES .....	55
ADJUSTING FLIP BACK ARMRESTS .....	27	CHARGING BATTERIES .....	56
ADJUSTING CAPTAIN'S SEAT ARMRESTS .....	28	REPLACING BATTERIES .....	57
<b>PROCEDURE 5 - UPHOLSTERY/ CAPTAIN'S SEAT/POSITIONING STRAP</b> .....	<b>29</b>	INSTALLING/REMOVING BATTERY BOXES ...	58
REPLACING SEAT UPHOLSTERY .....	29	ADJUSTING THE STABILIZERS .....	59
ADJUSTING CAPTAIN'S SEAT .....	29	BATTERY TRAY .....	59
REMOVING/INSTALLING CAPTAIN'S SEAT .....	30	<b>LIMITED WARRANTY</b> .....	<b>BACK COVER</b>
REPLACING SEAT POSITIONING STRAP .....	30		
<b>PROCEDURE 6 - ELECTRONICS</b> .....	<b>31</b>		
PREPARING MKIV JOYSTICK FOR USE .....	31		
REPOSITIONING MKIV JOYSTICK .....	31		
DISCONNECTING/CONNECTING LIMIT SWITCH .....	31		

# SPECIFICATIONS

SPECIFICATIONS

	RANGER II MWD - RANGER II <sub>BASIC</sub>	RANGER II <sub>STANDARD</sub>	RANGER II <sub>250 SERIES</sub>
	<b>INTEGRATED SLING SEAT</b>		<b>CAPTAIN'S SEAT</b>
			<b>BACK TYPE</b>
			<b>LOW SOLID SEAT (LOBSS)</b>
			<b>HIGH<sup>1</sup> (HIB)</b>
<b>Seat Width Range:</b>	16, 18 or 20-inches		
<b>Seat Depth Range:</b>	16, 17 or 18-in. - in 1-inch increments (17 and 18-in. by extension)		
<b>Back Height Range Std.:</b>	16, 17, 18, 19 or 20-in. - In 1-in increments	16-in.	18-in.
<b>Opt. Headrest:</b>	N/A	N/A	22-in.
<b>Opt. Backrest Ext.:</b>	N/A	23-in.	28-in.
<b>Back Angle Range:</b>	90° to 105° - in 5° increments	(55° - 114°) <sup>2</sup>	(98°) <sup>2</sup> (35° - 170°) <sup>2</sup>
<b>Seat-to-Floor:</b>	18-1/4-inches	22-in.	19-1/2-in. 22-in.
<b>Overall Width (No joystick):</b>	24-7/8-inches	24-3/4-in.	24-3/4-in. 24-3/4-in.
<b>Overall Height:</b>	34-3/8-in. - 18-in. Back Height	35-in.	35-in. 39-in.
<b>Weight<sup>3,6</sup></b>			
	<b>RANGER II<sub>BASIC</sub></b>	<b>RANGER II<sub>STANDARD</sub></b>	<b>RANGER II<sub>BASIC</sub></b>
	<b>RANGER II<sub>250 SERIES</sub></b>		<b>RANGER II<sub>250 STANDARD</sub></b>
<b>W/O Batteries:</b>	110 to 114 lbs.	112 to 116 lbs.	131 to 135 lbs.
<b>W/Batteries (Gel Cell):</b>	178 to 182 lbs.	190 to 194 lbs.	206 to 210 lbs.
<b>Shipping:</b>	134 to 153 lbs.	146 to 155 lbs.	161 to 165 lbs.
<b>Armrests:</b>	Removable, Flip Back, Fixed or Adjustable Height - Desk and Full Length		Flip Back - Adjustable Height - Full Length (Std.)
<b>Upholstery:</b>	Black Nylon		Vinyl or Cloth with Vinyl (RANGER II <sub>250 SERIES</sub> - Gray fabric trimmed w/ gray Vinyl)

	INTEGRATED SLING SEAT AND CAPTAIN'S SEAT
<b>Overall Length</b> (Drive wheel in Front Position - Refer to <b>PERCENTAGE OF WEIGHT DISTRIBUTION</b> in <b>PROCEDURE 1</b> of this manual.)	43-1/2-inches <b>(With 8-in. rear casters and 93 front riggings)</b>
<b>Front Stabilizers</b>	7-inch Urethane
<b>Drive Wheels/Tires:</b>	12-1/2 x 2-1/4-in. (Std.); 14-in.x 3-in. (Opt.) (Flat Free or Pneumatic)
<b>Casters w/Precision Sealed Bearings:</b>	8 x 1-3/4-in. Semi Pneumatic (Std.), 8 x 2-in. Pneumatic (Opt.) 6 x 2-in. Semi Pneumatic (Opt.)
<b>Footrest/Legrest:</b>	Swingaway, Removable Footboard
<b>Battery/Size (Not Supplied):</b>	RANGER II <sub>BASIC</sub> /RANGER II <sub>STANDARD</sub> - 22NF Gel Cell (Two (2) Required); RANGER II <sub>250 SERIES</sub> uses - U1 GEL CELL)

PERFORMANCE	RANGER II <sub>BASIC</sub>	RANGER II <sub>250 SERIES</sub>	RANGER II <sub>STANDARD</sub>
<b>Speed (M.P.H.):</b>	0 to 3.8	0 to 3.6	0 to 4.8
<b>Turning Radius:</b>	≥ 23-inches	≥ 23-inches	≥ 23-inches
<b>Range (variable)<sup>4</sup>:</b>	18-22 miles	12-14 miles	18-22 miles
<b>❖ Weight Limitation<sup>5</sup>:</b>	250 lbs.	250 lbs.	300 lbs.

❖ **NOTE:** Refer to **PERCENTAGE OF WEIGHT DISTRIBUTION** in **PROCEDURE 1** of this manual.

**Footnotes:**

1. High Back not available on model RANGER II<sub>250 SERIES</sub>.
2. Low and High Back Types have an Infinite adjustment. Low Backs with Solid Seat have no adjustment.
3. 18-in. wide x 16-in. deep wheelchair with MKIV RII electronics.
4. Range will vary with battery conditions, surface, terrain and operators weight.
5. Includes seating systems and accessories.
6. Weight varies between motors. RANGER II<sub>BASIC</sub> AND RANGER II<sub>250 SERIES</sub> have clutches. The RANGER II<sub>STANDARD</sub> has motor locks.

# SPECIFICATIONS

	RANGER II FWD -RANGER II <sub>BASIC</sub>	RANGER II <sub>STANDARD AND</sub>	AND RANGER II <sub>250 SERIES</sub>
	INTEGRATED SLING SEAT		CAPTAIN'S SEAT
			BACK TYPE
			LOW SOLID SEAT (LOBSS)
			HIGH (HIB)
Seat Width Range:	16, 18 or 20-inches	19-in.	19-in. 19-in.
Seat Depth Range:	16, 17 or 18-in. - In 1-in. increments (17 and 18-in. by extension)	17-in.	17-in. 17-in.
Back Height Range Std.:	16, 17, 18, 19 or 20-in. - In 1-in. increments	16-in.	18-in. 22-in.
Opt. Headrest:	N/A	N/A	N/A 28-in.
Opt. Backrest Ext.:	N/A	23-in.	N/A N/A
Back Angle Range:	90° to 105° - in 5° increments	(55° - 114°) <sup>1</sup>	(98°) <sup>1</sup> (35° - 170°) <sup>1</sup>
Seat-to-Floor:	18-1/2-in.	22-in.	19-1/2-in. 22-in.
Overall Width (No joystick):	24-5/8-in.	24-3/4-in.	24-3/4-in. 24-3/4-in.
Overall Height:	34-3/8-in. - 16-in. Back Height	35-in.	35-in. 39-in.
Weight <sup>2,5</sup> W/O Batteries:	<b>RANGER II<sub>BASIC</sub></b> <sup>5</sup>	<b>RANGER II<sub>STANDARD</sub></b> <sup>5</sup>	<b>RANGER II<sub>BASIC</sub></b> <sup>5</sup>
W/Batteries (Gel Cell):		<b>RANGER II<sub>250 SERIES</sub></b>	<b>RANGER II<sub>STANDARD</sub></b> <sup>5</sup>
Shipping:	90 to 100 lbs.	105 to 115 lbs.	122 to 127 lbs.
Armrests:	170 to 180 lbs.	185 to 195 lbs.	203 to 207 lbs.
Upholstery:	105 to 115 lbs.	120 to 130 lbs.	153 to 157 lbs.
	Removable, Flip Back, Fixed or Adjustable Height - Desk and Full Length		Flip Back - Adjustable Height - Full Length (Std.)
	Black Nylon		Vinyl or Cloth with Vinyl

	INTEGRATED SLING SEAT AND CAPTAIN'S SEAT		
	REAR POSITION	❖DRIVE WHEEL POSITION MIDDLE POSITION	FORWARD POSITION
Overall Length			
With 8-in. rear casters and 93 front riggings:	43-1/2-inches	43-1/2-inches	43-1/2-inches
With 8-in. rear casters and no front riggings:	32-1/2-inches	33-1/2-in.	N/A
Drive Wheels/Tires:	❖ NOTE: Refer to PERCENTAGE OF WEIGHT DISTRIBUTION in PROCEDURE 1 of this manual.		
Casters w/Precision Sealed Bearings:	12-1/2 x 2-1/4-in. (Std.); 14-in.x 3-in. (Opt.) (Flat Free or Pneumatic)		
Footrest/Legrest:	8 x 1-3/4-in. Semi Pneumatic (Std.), 8 x 2-in. Pneumatic (Opt.)		
Battery/Size (Not Supplied):	6 x 2-in. Semi Pneumatic (Opt.)		
	Swingaway, Removable Footboard		
	22NF Gel Cell (Two (2) Required)		

PERFORMANCE	RANGER II <sub>BASIC</sub>	RANGER II <sub>250 SERIES</sub>	RANGER II <sub>STANDARD</sub>
Speed (M.P.H.):	0 to 3.8	0 to 3.6	0 to 4.0
Turning Radius:	≥ 26-inches	≥ 25.8-inches	≥ 26-inches
Range (variable) <sup>3</sup> :	17-22 miles	12-14 miles	12-16 miles
❖ Weight Limitation <sup>4</sup> :	250 lbs.	250 lbs.	300 lbs.

❖ NOTE: Refer to PERCENTAGE OF WEIGHT DISTRIBUTION in PROCEDURE 1 of this manual.

- Footnotes:**
1. Low and High Back Types have an Infinite adjustment. Low Backs with Solid Seat have no adjustment.
  2. 18-in. wide x 16-in. deep wheelchair with MKIV RII electronics.
  3. Range will vary with battery conditions, surface, terrain and operators weight.
  4. Includes seating systems and accessories.
  5. Weight varies between motors. RANGER II<sub>BASIC</sub> has clutches. The RANGER II<sub>STANDARD</sub> has motor locks.

# SPECIFICATIONS

S  
P  
E  
C  
I  
F  
I  
C  
A  
T  
I  
O  
N  
S

RANGER II FWD - RANGER II <sub>JR</sub>	
	<b>INTEGRATED SLING SEAT</b>
<b>Seat Width Range:</b>	14-inches
<b>Seat Depth Range:</b>	16 to 18-inches - In 1-inch increments (17 and 18-inch by extension)
<b>Back Height Range:</b>	16 to 20-inches - In 1-inch increments
<b>Back Angle Range:</b>	90° to 105° - in 5° increments
<b>Seat-to-Floor:</b>	18-1/2-inches
<b>Overall Width (No joystick):</b>	20-5/8-inches
<b>Overall Height:</b>	34-3/8-inches - 16-inch Back Height
<b>Overall Length</b>	❖ REAR DRIVE POSITION
<b>With 8-inch rear casters and 93 front riggings:</b>	43-1/2-inches
<b>With 8-inch rear casters and no front riggings:</b>	32-1/2-inches ❖ <i>NOTE: Refer to PERCENTAGE OF WEIGHT DISTRIBUTION in PROCEDURE 1 of this manual.</i>
<b>Drive Wheels/Tires</b>	12-1/2 X 2-1/4-inch (Pneumatic-Standard, Flat Free - Optional)
<b>Caster w/Precision Sealed Bearings:</b>	8 x 1-3/4-inch Semi Pneumatic (Std.), 8 x 2-inch Pneumatic (Opt.) 6 x 2-inch Semi Pneumatic (Opt.)
<b>Footrests/Legrests:</b>	Swingaway, Removable Footrest
<b>Weight<sup>1</sup></b>	
<b>W/O Batteries:</b>	83 lbs.
<b>W/Batteries (Gel Cell):</b>	132 lbs.
<b>Shipping:</b>	98 lbs.
<b>Armrests:</b>	Removable, Flip Back, Fixed or Adjustable Height - Desk and Full Length
<b>Upholstery:</b>	Black Nylon
<b>Batteries:</b>	U1 Gel Cell

## PERFORMANCE

<b>Speed (M.P.H.):</b>	0 to 3.6
<b>Turning Radius:</b>	24-inches
<b>Range (variable)<sup>2</sup>:</b>	14 miles
<b>❖ Weight Limitation<sup>3</sup>:</b>	200 lbs.

❖ *NOTE: Refer to PERCENTAGE OF WEIGHT DISTRIBUTION in PROCEDURE 1 of this manual.*

### Footnotes:

1. 18-in. wide x 16-in. deep wheelchair with MKIV RII electronics.
2. Range will vary with battery conditions, surface, terrain and operators weight.
3. Includes seating systems and accessories.

***This Procedure Includes the Following:******Repair or Service Information******Operating Information******Safety/Handling of Wheelchairs******Warning/Caution Label Location - MWD Models******Warning/Caution Label Location - FWD Models*****WARNING****CONTROLLER SETTINGS FOR RANGER II<sub>JR</sub>**

Set-up of the Electronic Control Unit is to be performed **ONLY** by a qualified technician. Factory setting of the controller **MUST** be used for daily activities. Reprogramming the controller reduces the stability/controllability of the wheelchair. Other program settings could cause the wheelchair to tip over resulting in serious injury to the user and/or damage to the surrounding property.

**REPAIR OR SERVICE INFORMATION**

Set-up of the Electronic Control Unit is to be performed **ONLY** by a qualified technician. The final tuning adjustments of the controller may affect other activities of the wheelchair. Damage to the equipment could occur under these circumstances. If any individual other than an a qualified technician performs any work on these units, the warranty is void.

**OPERATING INFORMATION****GENERAL WARNINGS**

Performance adjustments should only be made by professionals of the healthcare field or persons fully conversant with this process and the driver's capabilities. Incorrect settings could cause injury to the driver, bystanders, damage to the chair and to surrounding property.

After the wheelchair has been set-up, check to make sure that the wheelchair performs to the specifications entered during the set-up procedure. If the wheelchair does **NOT** perform to specifications, turn the wheelchair **OFF** immediately and reenter set-up specifications. Repeat this procedure until the wheelchair performs to specifications.

**DO NOT** shift your weight or sitting position toward the direction you are reaching as the wheelchair may tip over.

**DO NOT** engage or disengage the motor locks/clutches until the power is in the **OFF** position.

**DO NOT** operate on roads, streets or highways.

**DO NOT** climb, go up or down ramps or traverse slopes greater than 9°.

**DO NOT** attempt to move up or down an incline with a water, ice or oil film.

**DO NOT** attempt to drive over curbs or obstacles. Doing so may cause your wheelchair to turn over and cause bodily harm or damage to the chair.

**DO NOT** use parts, accessories, or adapters other than those authorized by Invacare.

**DO NOT** leave the power button **ON** when entering or exiting your wheelchair.

**DO NOT** stand on the frame of the wheelchair.

**DO NOT** use the footplates as a platform. When getting in or out of the wheelchair, make sure that the footplates are in the upward position or swing footrests towards the outside of the chair.

**ALWAYS** wear your seat positioning strap.

**TIRE PRESSURE**

**DO NOT** use your wheelchair unless it has the proper tire pressure (P.S.I.). **DO NOT** overinflate the tires. Failure to follow these suggestions may cause the tire to explode and cause bodily harm. The recommended tire pressure is listed on the side wall of the tire.

**GENERAL WARNINGS (CONTINUED)****ELECTRICAL**

EXTREME care should be exercised when using oxygen in close proximity to electric circuits. Contact your oxygen supplier for instruction in the use of oxygen.

**BATTERIES**

The warranty and performance specifications contained in this manual are based on the use of deep cycle gel cell or sealed lead acid batteries. Invacare strongly recommends their use as the power source for this unit.

The use of rubber gloves and safety glasses is recommended when working with batteries.

Carefully read battery/battery charger information prior to installing, servicing or operating your wheelchair.

**GROUNDING INSTRUCTIONS:**

DO NOT, under any circumstances, cut or remove the round grounding prong from any plug used with or for Invacare products. Some devices are equipped with three-prong (grounding) plugs for protection against possible shock hazards. Where a two-prong wall receptacle is encountered, it is the personal responsibility and obligation of the customer to contact a qualified electrician and have the two-prong receptacle replaced with a properly grounded three-prong wall receptacle in accordance with the National Electrical Code. If you must use an extension cord, use ONLY a three-wire extension cord having the same or higher electrical rating as the device being connected. In addition, Invacare has placed RED/ORANGE WARNING TAGS on some equipment. DO NOT remove these tags.

**RAIN TEST**

INVACARE has tested its power wheelchairs in accordance with ISO 7176 Part 9 "Rain Test". This provides the end user or his/her assistant sufficient time to remove his/her power wheelchair from a rain storm and retain wheelchair operation.

DO NOT leave power wheelchair in a rain storm of any kind.

DO NOT use power wheelchair in a shower or leave it in a damp bathroom while taking a shower.

DO NOT leave power wheelchair in a damp area for any length of time.

Direct exposure to rain or dampness will cause the chair to malfunction electrically and mechanically; may cause the chair to prematurely rust.

Check to ensure that the battery covers are secured in place, joystick boot is NOT torn or cracked where water can enter and that all electrical connections are secure at all times.

DO NOT use the joystick if the boot is torn or cracked. If the joystick boot becomes torn or cracked, replace IMMEDIATELY.

**WEIGHT TRAINING**

Invacare DOES NOT recommend the use of its wheelchairs as a weight training apparatus. Invacare wheelchairs have NOT been designed or tested as a seat for any kind of weight training. If occupant uses said wheelchair as a weight training apparatus, INVACARE SHALL NOT BE LIABLE FOR BODILY INJURY AND THE WARRANTY IS VOID.

**WEIGHT LIMITATION**

The Ranger II MWD models that have motors with clutches have a weight limitation of 250 lbs. The Ranger II MWD models that have motors with motor locks have a weight limitation of 300 lbs. The Ranger II MWD models that have the weight shift tilt seating system have a weight limitation of 250 lbs.

The Ranger II FWD models that have motors with clutches have a weight limitation of 250 lbs. EXCEPT RANGER II<sub>JR</sub> which has a weight limitation of 200 lbs. The Ranger II FWD models that have motors with motor locks have a weight limitation of 300 lbs. Refer to PERCENTAGE OF WEIGHT DISTRIBUTION in this procedure of the manual.



## SAFETY/HANDLING OF WHEELCHAIRS

"Safety and Handling" of the wheelchair requires the close attention of the wheelchair user as well as the assistant. This manual points out the most common procedures and techniques involved in the safe operation and maintenance of the wheelchair. It is important to practice and master these safe techniques until you are comfortable in maneuvering around the frequently encountered architectural barriers.

Use this information only as a "basic" guide. The techniques that are discussed on the following pages have been used successfully by many.

Individual wheelchair users often develop skills to deal with daily living activities that may differ from those described in this manual. Invacare recognizes and encourages each individual to try what works best for him/her in overcoming architectural obstacles that they may encounter, however, ALL WARNINGS and CAUTIONS given in this manual MUST be followed. Techniques in this manual are a starting point for the new wheelchair user and assistant with "safety" as the most important consideration for all.

### Stability and Balance

#### WARNING

**ALWAYS wear your seat positioning strap.**

To assure stability and proper operation of your wheelchair, you must at all times maintain proper balance. Your wheelchair has been designed to remain upright and stable during normal daily activities as long as you do not move beyond the center of gravity. DO NOT lean forward out of the wheelchair any further than the length of the armrests.

### Coping With Everyday Obstacles

Coping with the irritation of everyday obstacles can be alleviated somewhat by learning how to manage your wheelchair. Keep in mind your center of gravity to maintain stability and balance.

### A Note to Wheelchair Assistants

When assistance to the wheelchair user is required, remember to use good body mechanics. Keep your back straight and bend your knees whenever tilting wheelchair or traversing curbs, or other impediments.

Also, be aware of detachable parts such as arms or leg-rests. These must NEVER be used for hand-hold or lifting supports, as they may be inadvertently released, resulting in possible injury to the user and/or assistant(s).

When learning a new assistance technique, have an experienced assistant help you before attempting it alone.

## Stairways

#### WARNING

**DO NOT attempt to move an occupied power wheelchair between floors using a stairway. Use an elevator to move an occupied power wheelchair between floors. If moving a power wheelchair between floors by means of a stairway, the occupant MUST be removed and transported independently of the power wheelchair.**

Extreme caution is advised when it is necessary to move an UNOCCUPIED power wheelchair up or down the stairs. Invacare recommends using two (2) assistants and making thorough preparations. Make sure to use ONLY secure, non-detachable parts for hand-hold supports.

**DO NOT attempt to lift the wheelchair by any removable (detachable) parts. Lifting by means of any removable (detachable) parts of a wheelchair may result in injury to the user or damage to the wheelchair.**

**Follow this procedure for moving the wheelchair between floors when an elevator is NOT available:**

#### WARNING

**The weight of the wheelchair without the user and batteries is still between 83 and 142 lbs. Use proper lifting techniques (lift with your legs) to avoid injury.**

1. Remove the occupant from the wheelchair.
2. Remove the battery boxes from the wheelchair. Refer to one (1) of the following:
  - FWD WHEELCHAIRS - INSTALLING/REMOVING BATTERY BOXES** in PROCEDURE 11 of this manual.
  - MWD WHEELCHAIRS - INSTALLING/REMOVING BATTERY BOXES** in PROCEDURE 12 of this manual.
3. Bend your knees and keep your back straight.
4. Using non-removable (non-detachable) parts of the wheelchair, lift the wheelchair off of the ground and transfer the wheelchair up or down the stairs.
5. The wheelchair should not be lowered until the last stair has been negotiated and the wheelchair has been carried away from the stairway.

#### ESCALATORS? SORRY!

**DO NOT use an escalator to move a wheelchair between floors. Serious bodily injury may occur.**

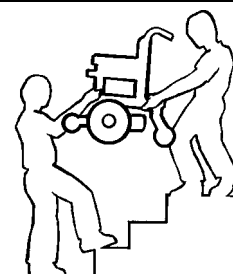

**Transferring to and From Other Seats**

**WARNING**

ALWAYS turn the wheelchair power OFF and engage the motor locks/clutches to prevent the wheels from moving BEFORE attempting to transfer in or out of the wheelchair. Also, make sure every precaution is taken to reduce the gap distance aligning both rear casters parallel with the object you are transferring onto.

**CAUTION**

When transferring, position yourself as far back as possible in the seat. This will prevent broken screws, damaged upholstery and the possibility of the wheelchair tipping forward.

*NOTE: This activity may be performed independently provided you have adequate mobility and upper body strength.*

1. Position the wheelchair as close as possible along side the seat to which you are transferring, with the rear casters pointing away from it.
2. Engage motor locks/clutches. Refer to one (1) of the following.
  - A. **WHEELCHAIRS WITH MOTORS THAT HAVE CLUTCHES** - ENGAGING/DISENGAGING MOTORS WITH CLUTCHES in PROCEDURE 8 of this manual.
  - B. **WHEELCHAIRS WITH MOTORS THAT HAVE MOTOR LOCKS** - ENGAGING/DISENGAGING MOTORS WITH MOTOR LOCKS in PROCEDURE 8 of this manual.
3. Shift body weight into seat with transfer.

During independent transfer, little or no seat platform will be beneath you. Use a transfer board if at all possible.

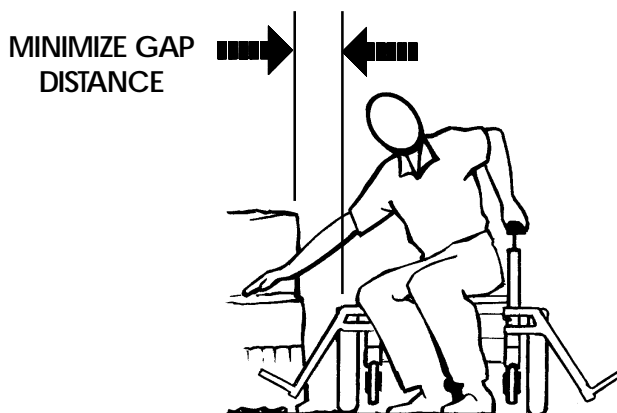

**Percentage of Weight Distribution**

**WARNING**

DO NOT attempt to reach objects if you have to move forward in the seat or pick them up from the floor by reaching down between your knees.

Many activities require the wheelchair user to reach, bend and transfer in and out of the wheelchair. These movements will cause a change to normal balance, center of gravity, and weight distribution of the wheelchair. To determine and establish your particular safety limits, practice bending, reaching and transferring activities in several combinations in the presence of a qualified healthcare professional BEFORE attempting active use of the wheelchair.

Proper positioning is essential for your safety. When reaching, leaning, bending or bending forward, it is important to use the rear casters as a tool to maintain stability and balance.

**RII MWD WHEELCHAIRS ONLY.**

**WARNING**

NEVER reposition the motors. Repositioning the motors rearward WILL reduce the stability of the wheelchair. This procedure MUST be performed by an Invacare Dealer.

**RII FWD MODEL WHEELCHAIRS ONLY (FIGURE 1).**

**WARNING**

The overall performance of the wheelchair WILL be affected by the front wheel mounting position. The following charts show the mounting position of the motors for each seat width and depth depending on the factory setting or user's weight.

If the mounting position that corresponds to the user's weight is different than the factory setting, the motors MUST BE repositioned to maintain proper stability and controllability BEFORE using the wheelchair. Otherwise injury or damage can occur.

Periodically review the following charts to make sure the motor mounting position still corresponds to the user's weight to maintain the proper stability and controllability.

Repositioning the motors MUST be performed by an Invacare Dealer.

RANGER II<sub>JR</sub> ONLY - NEVER reposition the motors. Repositioning the motors forward WILL reduce the controllability of the wheelchair. This procedure MUST be performed by an Invacare Dealer.

*NOTE: If motors are repositioned, the front riggings may need to be repositioned. Refer to ADJUSTING/REPLACING TELESCOPING FRONT RIGGING SUPPORT in PROCEDURE 3 of this manual.*

FACTORY SETTINGS - MOTOR MOUNTING POSITIONS (MOTORS WITH MOTOR LOCKS)

SEAT WIDTH	SEAT DEPTH		
	16	17	18
*14	N/A	N/A	N/A
16	FRONT	FRONT	FRONT
18	FRONT	FRONT	FRONT
20	FRONT	FRONT	FRONT

FACTORY SETTINGS - MOTOR MOUNTING POSITIONS (MOTORS WITH CLUTCHES)

SEAT WIDTH	SEAT DEPTH		
	16	17	18
*14	REAR	REAR	REAR
16	MIDDLE	MIDDLE	MIDDLE
18	MIDDLE	MIDDLE	MIDDLE
20	MIDDLE	MIDDLE	MIDDLE

USERS' WEIGHT 200 LBS AND UNDER - MOTOR MOUNTING POSITIONS

SEAT WIDTH	SEAT DEPTH		
	16	17	18
*14	REAR	REAR	REAR
16	REAR	REAR </td <td>REAR</td>	REAR
18	REAR	REAR	REAR
20	REAR	REAR	REAR

USERS' WEIGHT 201 TO 250 LBS - MOTOR MOUNTING POSITIONS

SEAT WIDTH	SEAT DEPTH		
	16	17	18
*14	N/A	N/A	N/A
16	MIDDLE	MIDDLE	MIDDLE
18	MIDDLE	MIDDLE	MIDDLE
20	MIDDLE	MIDDLE	MIDDLE

USERS' WEIGHT 251 TO 300 LBS (FWD MOTORS WITH MOTOR LOCKS ONLY)- MOTOR MOUNTING POSITIONS

SEAT WIDTH	SEAT DEPTH		
	16	17	18
*14	N/A	N/A	N/A
16	FRONT	FRONT	FRONT
18	FRONT	FRONT	FRONT
20	FRONT	FRONT	FRONT

\*NOTE: 14 wide is only for RANGER II<sub>JR</sub>

FIGURE 1 shows the motor mounting positions.

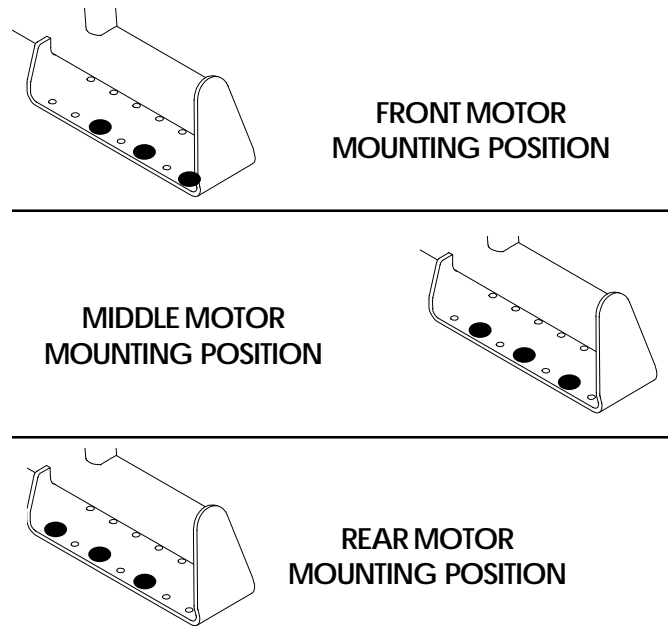
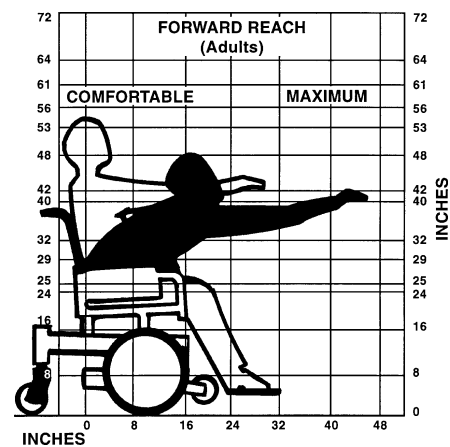

FIGURE 1 - PERCENTAGE OF WEIGHT DISTRIBUTION - FWD WHEELCHAIRS ONLY

Functional Reach From a Wheelchair

The approximate reach-limit values shown in the accompanying graphs were derived on the basis of a sample of 91 male and 36 female wheelchair users. Note the difference between the maximum and the comfortable reach limits, a subjective but important consideration in design.



Reaching, Leaning, Bending and Bending - Forward

Position the rear casters so that they are extended as far rearward as possible and engage motor locks/clutches. **DO NOT ATTEMPT TO REACH OBJECTS IF YOU HAVE TO MOVE FORWARD IN THE SEAT OR PICK THEM UP FROM THE FLOOR BY REACHING DOWN BETWEEN YOUR KNEES.**

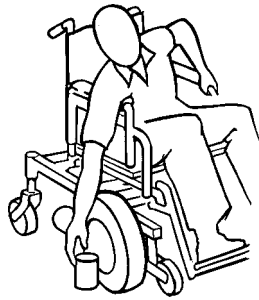
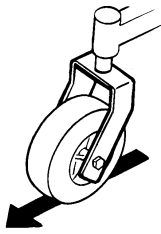
**Reaching, Bending - Backward****WARNING**

DO NOT lean over the top of the back upholstery. This will change your center of gravity and may cause you to tip over.

Position wheelchair as close as possible to the desired object. Point rear casters rearward to create the longest possible wheelbase. Reach back only as far as your arm will extend without changing your sitting position.

**WARNING**

**CAUTION: IT IS VERY IMPORTANT THAT YOU READ THIS INFORMATION REGARDING THE POSSIBLE EFFECTS OF ELECTROMAGNETIC INTERFERENCE ON YOUR POWERED WHEELCHAIR.**

Electromagnetic Interference (EMI) From Radio Wave sources

Powered wheelchairs and motorized scooters (in this text, both will be referred to as powered wheelchairs) may be susceptible to electromagnetic interference (EMI), which is interfering electromagnetic energy (EM) emitted from sources such as radio stations, TV stations, amateur radio (HAM) transmitters, two way radios, and cellular phones. The interference (from radio wave sources) can cause the powered wheelchair to release its brakes, move by itself, or move in unintended directions. It can also permanently damage the powered wheelchair's control system. The intensity of the interfering EM energy can be measured in volts per meter (V/m). Each powered wheelchair can resist EMI up to a certain intensity. This is called its "immunity level." The higher the immunity level, the greater the protection. At this time, current technology is capable of achieving at least a 20 V/m immunity level, which would provide useful protection from the more common sources of radiated EMI. This powered wheelchair model as shipped has an unknown immunity level.

There are a number of sources of relatively intense electromagnetic fields in the everyday environment. Some of these sources are obvious and easy to avoid. Others are not apparent and exposure is unavoidable. However, we believe that by following the warnings listed below, your risk to EMI will be minimized.

The sources of radiated EMI can be broadly classified into three types:

- 1) Hand-held Portable transceivers (transmitters-receivers with the antenna mounted directly on the transmitting unit. Examples include: citizens band (CB) radios, "walkie talkie", security, fire and police transceivers, cellular telephones, and other personal communication devices. **\*\*NOTE:** Some cellular telephones and similar devices transmit signals while they are ON, even when not being used;
- 2) Medium-range mobile transceivers, such as those used in police cars, fire trucks, ambulances, and taxis. These usually have the antenna mounted on the outside of the vehicle; and
- 3) Long-range transmitters and transceivers, such as commercial broadcast transmitters (radio and TV broadcast antenna towers) and amateur (HAM) radios.

**NOTE:** Other types of hand-held devices, such as cordless phones, laptop computers, AM/FM radios, TV sets, CD players, cassette players, and small appliances, such as electric shavers and hair dryers, so far as we know, are not likely to cause EMI problems to your powered wheelchair.

**WARNING****Powered Wheelchair Electromagnetic Interference (EMI)**

Because EM energy rapidly becomes more intense as one moves closer to the transmitting antenna (source), the EM fields from hand-held radio wave sources (transceivers) are of special concern. It is possible to unintentionally bring high levels of EM energy very close to the powered wheelchair's control system while using these devices. This can affect powered wheelchair movement and braking. Therefore, the warnings listed below are recommended to prevent possible interference with the control system of the powered wheelchair.

Electromagnetic interference (EMI) from sources such as radio and TV stations, amateur radio (HAM) transmitters, two-way radios, and cellular phones can affect powered wheelchairs and motorized scooters. Following the warnings listed below should reduce the chance of unintended brake release or powered wheelchair movement which could result in serious injury.

- 1) Do not operate hand-held transceivers (transmitters receivers), such as citizens band (CB) radios, or turn ON personal communication devices, such as cellular phones, while the powered wheelchair is turned ON;
- 2) Be aware of nearby transmitters, such as radio or TV stations, and try to avoid coming close to them;
- 3) If unintended movement or brake release occurs, turn the powered wheelchair OFF as soon as it is safe;
- 4) Be aware that adding accessories or components, or modifying the powered wheelchair, may make it more susceptible to EMI (Note: There is no easy way to evaluate their effect on the overall immunity of the powered wheelchair); and
- 5) Report all incidents of unintended movement or brake release to the powered wheelchair manufacturer, and note whether there is a source of EMI nearby.

**Important Information**

- 1) 20 volts per meter (V/m) is a generally achievable and useful immunity level against EMI (as of May 1994) (the higher the level, the greater the protection);
- 2) The MCC MKIV controller for this application has an unknown immunity level.

Modification of any kind to the electronics of this wheelchair as manufactured by Invacare may adversely affect the RFI immunity levels.

# WARNING/CAUTION LABEL LOCATION - MWD MODELS (RANGER II<sub>BASIC</sub> / RANGER II<sub>STANDARD</sub> / RANGER II<sub>250 SERIES</sub>)

GENERAL GUIDELINES

**CAUTION**  
 HIGHBACK CAPTAIN'S SEATS ONLY - Disconnect limit switch BEFORE removing seat - damage to seat can occur.  
 1076575

**CAUTION**

**ENGAGE**  
 STEP 2: PUSH FORWARD  
 STEP 1: PUSH IN

**DISENGAGE**  
 STEP 1: PULL BACK  
 STEP 2: PULL OUT

ENSURE BOTH CLUTCHES ARE FULLY ENGAGED BEFORE DRIVING CHAIR  
 1074126

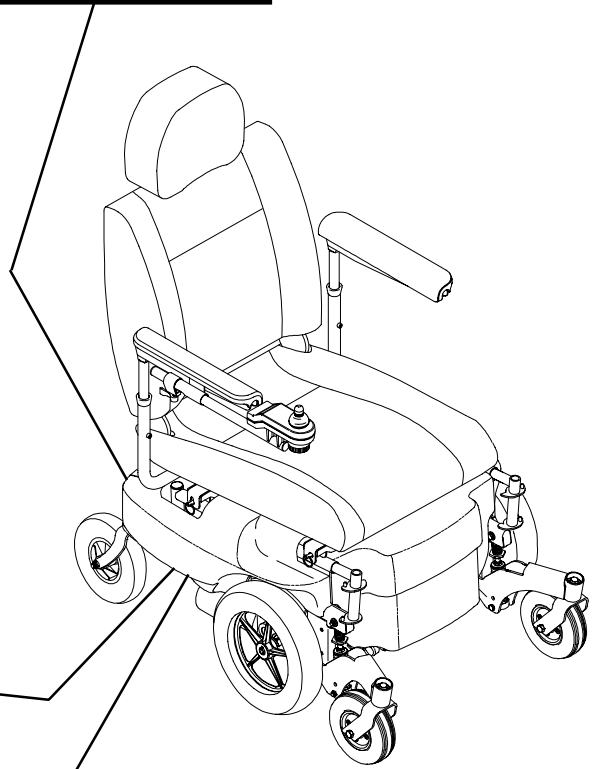

**WARNING**  
 PINCH POINTS  
 PUSH HERE TO OPEN CHAIR | PULL HERE TO FOLD CHAIR  
 1074142

Crossbrace  
 Push Bracket

# WARNING/CAUTION LABEL LOCATION - FWD MODELS (RANGER II<sub>BASIC</sub>/RANGER II<sub>STANDARD</sub>/RANGER II<sub>250 SERIES</sub>)

GENERAL GUIDELINES

**WARNING**  
Replacement controller **MUST** be SAME part number. 1080266

Controller (Back View)

Side Frame

**CAUTION**

**ENGAGE**  
STEP 2: PUSH FORWARD  
STEP 1: PUSH IN

**DISENGAGE**  
STEP 1: PULL BACK  
STEP 2: PULL OUT

ENSURE BOTH CLUTCHES ARE FULLY ENGAGED BEFORE DRIVING CHAIR

1074126

Motor Assembly

**CAUTION**  
HIGH BACK CAPTAIN'S SEATS ONLY - Disconnect limit switch **BEFORE** removing seat - damage to seat can occur. 1076575

*NOTE: Caution Label is located on side shroud.*

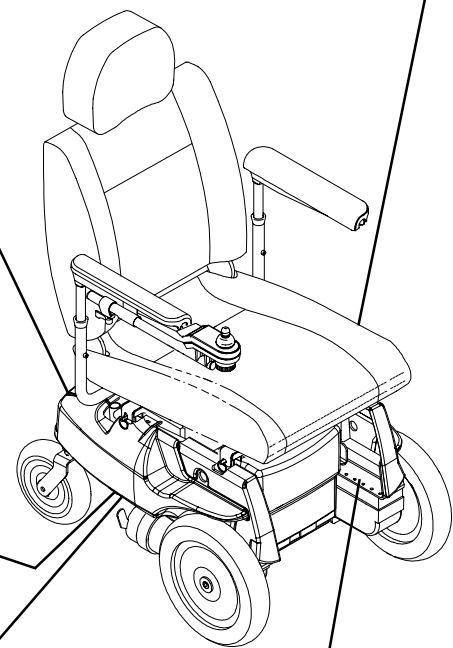

**WARNING**  
PINCH POINTS  
PUSH HERE TO OPEN CHAIR | PULL HERE TO FOLD CHAIR  
1074142

Crossbrace  
Push Bracket

**CAUTION**  
Repositioning the motors **WILL** affect the stability and/or performance of the wheelchair. Refer to PERCENTAGE OF WEIGHT DISTRIBUTION in the Owner's Manual **BEFORE** repositioning motors. 1080267

# WARNING/CAUTION LABEL LOCATION - FWD MODELS (RANGER II<sub>JR</sub>)

GENERAL GUIDELINES

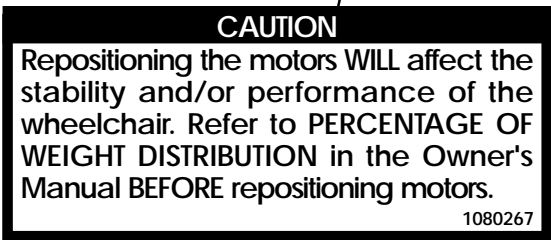
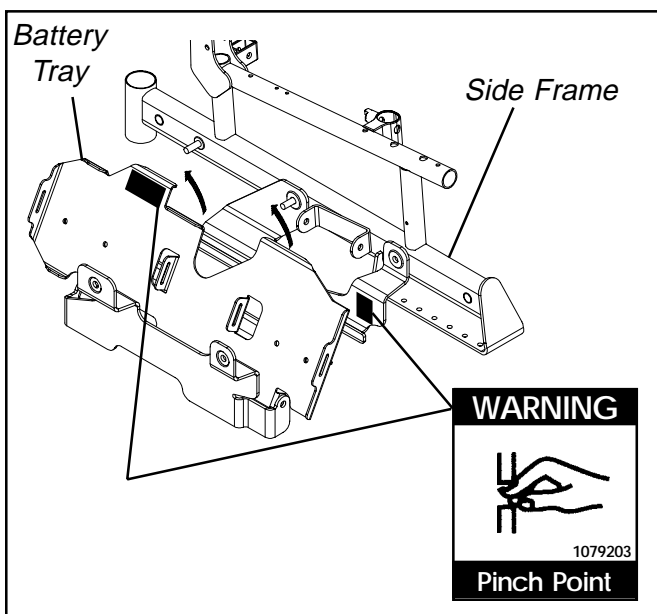
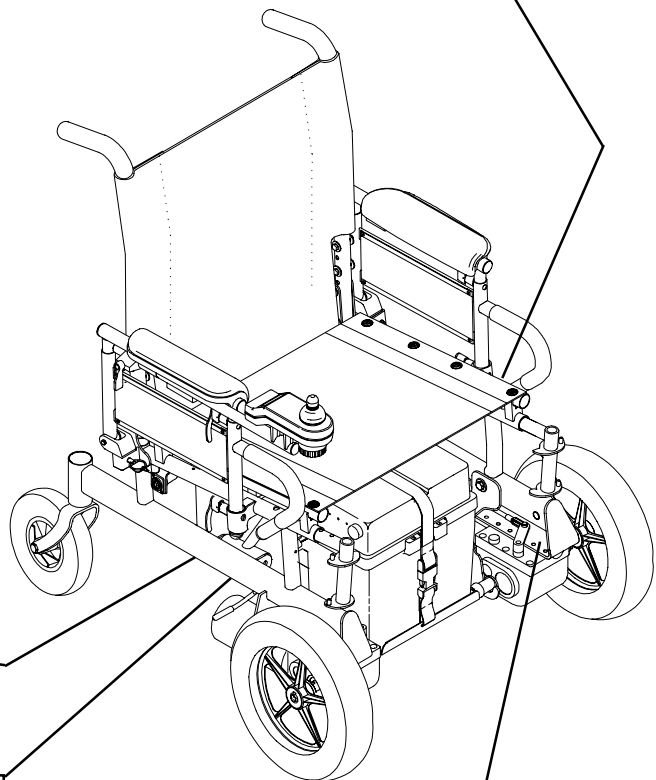
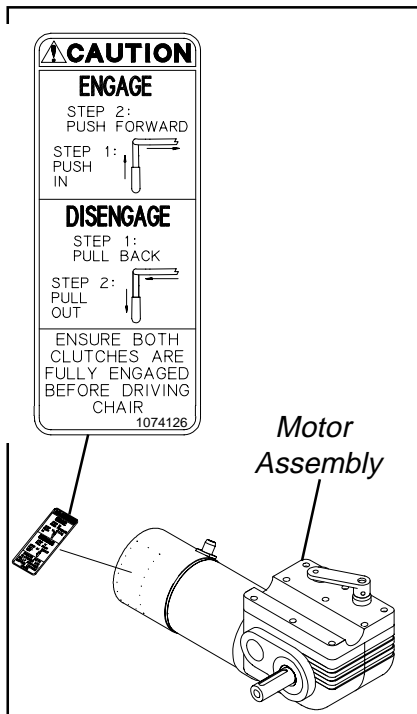



## BATTERY BOX SHIPPING INSERTS

### REMOVING BATTERY BOX SHIPPING INSERTS (RANGER II<sup>250</sup> SERIES ONLY) (FIGURE 1)

*NOTE: Wheelchairs ordered with batteries installed have shipping inserts which must be removed before using the wheelchair.*

1. Remove the battery boxes from the wheelchair. Refer to INSTALLING/REMOVING BATTERY BOXES in PROCEDURE 11 (RWD) or PROCEDURE 12 (MWD) of this manual.
2. Lift up on the shipping inserts to remove from the battery boxes
3. Install the battery boxes onto the wheelchair. Refer to INSTALLING/REMOVING BATTERY BOXES in PROCEDURE 11 (RWD) or PROCEDURE 12 (MWD) of this manual.

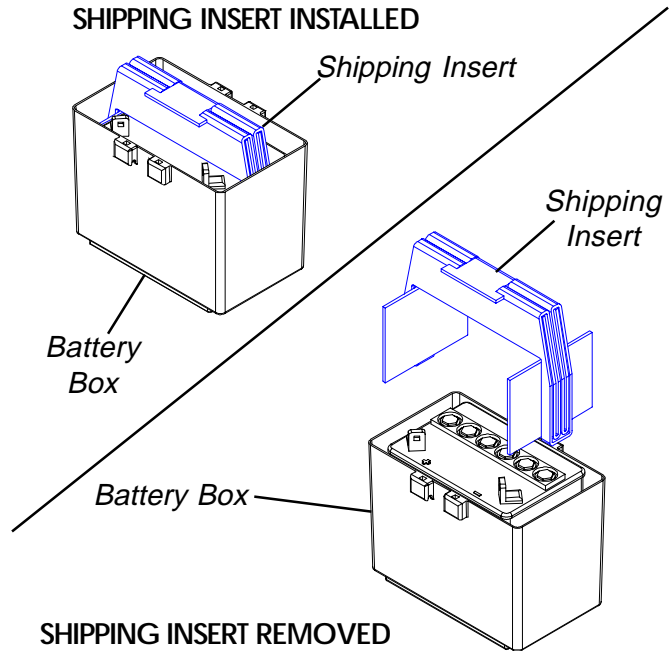

*NOTE: Battery box lid not shown for clarity.*

FIGURE 1 - REMOVING BATTERY BOX SHIPPING INSERTS

*This Procedure Includes the Following:*

*Troubleshooting*

*Checking Battery Charge Level*

*Safety Inspection Checklist*

**TROUBLESHOOTING - MECHANICAL**

CHAIR VEERS LEFT/RIGHT	SLUGGISH TURN/ PERFORMANCE	CASTERS FLUTTER	SQUEAKS AND RATTLES	LOOSENESS IN CHAIR	CHAIR 3 WHEELS	SOLUTIONS
X	X	X			X	If pneumatic, check tires for correct and equal pressure.
X	X	X	X	X		Check for loose stem nuts/bolts.
X		X				Check that both casters contact ground at the same time.

**TROUBLESHOOTING - ELECTRICAL**

SYMPTOM	PROBABLE CAUSE	SOLUTIONS
Battery won't charge	Blown Fuse. (RANGER II <sub>JR</sub> ONLY)	Replace fuse (PROCEDURE 6). (RANGER II <sub>JR</sub> ONLY)
Batteries draw excessive current when charging.	Battery failure.	Check batteries for shorted cell. Replace if necessary (FWD-PROCEDURE 11, MWD-PROCEDURE 12).
Battery indicator flashes the charge level is low—immediately after re-charge.	Electrical malfunction. Battery failure.  Malfunctioning battery charger. Electrical malfunction.	Contact Dealer/Invacare for Service. Check batteries for shorted cell. Replace if necessary (FWD-PROCEDURE 11, MWD-PROCEDURE 12). Contact Dealer/Invacare for Service. Poor connections between charger and wheelchair. Contact Dealer/Invacare for Service.
Battery indicator flashes the charge level is low—too soon after being recharged.	Batteries not charged. Weak batteries.  Electrical malfunction.	Have charger checked. Replace batteries if necessary (FWD-PROCEDURE 11, MWD-PROCEDURE 12). Contact Dealer/Invacare for Service.
Motor "chatters" or runs irregular.	Electrical malfunction.	Contact Dealer/Invacare for Service.
Wheelchair does not respond to commands. Power "ON", battery indicator flashes.	One (1) or both motor locks/clutches disengaged.	Engage motor locks/clutches (PROCEDURE 8).
Only one (1) rear wheel turns.	Electrical malfunction. One (1) motor lock/clutch is disengaged.	Contact Dealer/Invacare for Service. Engage motor lock/clutch (PROCEDURE 8).
Joystick erratic or does not respond as desired.	Electrical malfunction. Controller Programed improperly.	Contact Dealer/Invacare for Service. Contact Dealer/Invacare for Service.
Wheelchair does not respond to commands. Power indicator OFF—even after recharging.	Poor battery terminal connection.  Electrical malfunction.	Clean terminals (FWD-PROCEDURE 11, MWD-PROCEDURE 12). Contact Dealer/Invacare for Service.

*NOTE: For additional troubleshooting information and explanation of error codes, refer to the individual CONTROLLER MANUAL supplied with each wheelchair.*

**CHECKING BATTERY CHARGE LEVEL**

The following "Do's" and "Don'ts" are provided for your convenience and safety.

DON'T	DO
Don't perform any installation or maintenance without first reading this manual.	Read and understand this manual and any service information that accompanies a battery and charger before operating the wheelchair.
Don't perform installation or maintenance of batteries in an area that could be damaged by battery spills.	Move the wheelchair to a work area before checking the fluid level, adding distilled water, cleaning terminals, or opening battery box.

DON'T	DO
Don't make it a habit to discharge batteries to the lowest level.	Recharge as frequently as possible to maintain a high charge level and extend battery life.
Don't use randomly chosen batteries/chargers.	Follow recommendations in this manual when selecting a battery or charger.
Don't put new batteries into service before charging.	Fully charge a new battery before using.
Don't tip or tilt batteries.	Use a lifting strap to remove, move or install a battery.
Don't use ordinary tap water.	ONLY use distilled water to refill.
Don't overfill cells.	Keep the liquid level in the cells at the "split ring" level.
Don't use uneven levels of distilled water in cells.	Maintain the liquid in all cells at the "split ring" level.
Don't tap on clamps or terminals with tools.	Push battery clamps onto terminals. Spread clamps wider if necessary.
Don't mismatch your battery and chargers.	Use ONLY a GEL charger for a GEL or sealed battery and a regular charger for regular batteries.

**Using Hydrometer to Check Battery Cells (Lead Acid) (FIGURE 1)**

NOTE: Perform this procedure when a digital voltmeter is not available.

**WARNING**

NEVER smoke or strike a match near the batteries. If the caps of battery cells are removed, NEVER look directly into them when charging battery.

The use of rubber gloves and safety glasses is recommended when testing the battery cells.

When reading a hydrometer, DO NOT allow any liquid to come in contact with your eyes or skin. It is a form of acid and can cause serious burns, and in some cases, blindness. If you do get battery acid on you, flush the exposed areas with cool water IMMEDIATELY. If the acid comes into contact with eyes or causes serious burns, get medical help IMMEDIATELY.

The battery acid can damage your wheelchair, clothing, and household items. Therefore, take readings cautiously and only in designated areas.

ONLY use distilled water when topping off the battery cells.

Most batteries are not sold with instructions. However, warnings are frequently noted on the cell caps. Read them carefully.

5. Draw up sufficient acid to cover float balls.
6. Tap lightly to remove air bubbles.
7. Number of floating balls indicates charge.

**NUMBER OF FLOATING BALLS**

0	Discharged
1	25% Charged
2	50% Charged
3	75% Charged
4	100% Charged
* 5	Overcharged

\* Check charging system.

8. Flush the liquid back into the same cell after reading the float. Repeat this step until all cells have been properly read. A shorted or dead cell can be detected when it is the only cell that doesn't charge.
9. Flush hydrometer in cold running water by allowing the water to rise into the hydrometer as far as possible. Do this several times to guard against burn damage.
10. Replace the battery caps.
11. Install the battery boxes onto the wheelchair. Refer to one (1) of the following:

**FWD WHEELCHAIRS - INSTALLING/REMOVING BATTERY BOXES** in PROCEDURE 11 of this manual.

**MWD WHEELCHAIRS - INSTALLING/REMOVING BATTERY BOXES** in PROCEDURE 12 of this manual.

1. Remove the battery boxes from the wheelchair. Refer to one (1) of the following:

**FWD WHEELCHAIRS - INSTALLING/REMOVING BATTERY BOXES** in PROCEDURE 11 of this manual.

**MWD WHEELCHAIRS - INSTALLING/REMOVING BATTERY BOXES** in PROCEDURE 12 of this manual.

2. Remove the battery caps from the battery.
3. Squeeze the air from the hydrometer.
4. Place the hydrometer into a battery cell.

NOTE: DO NOT fill hydrometer more than 3/4 full.

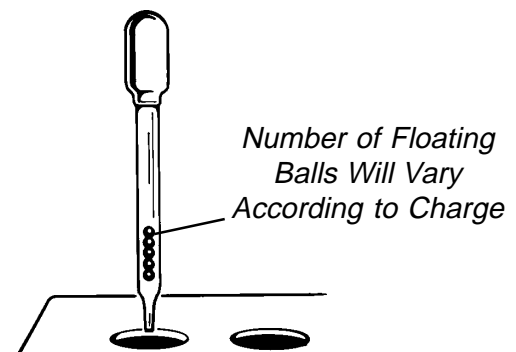

**FIGURE 1 - USING HYDROMETER TO CHECK BATTERY CELLS (LEAD ACID)**

### SAFETY INSPECTION CHECKLIST

Initial adjustments should be made to suit personal body structure and preference. Thereafter follow these maintenance procedures:

SAFETY INSPECTION

TROUBLESHOOTING

ITEM	INITIALLY	INSPECT/ ADJUST WEEKLY	INSPECT/ ADJUST MONTHLY	INSPECT/ ADJUST PERIODICALLY
<b>GENERAL (MECHANICAL TROUBLESHOOTING)</b> ● Wheelchair rolls straight (no excessive drag or pull to one side).	X			X
<b>CLOTHING GUARDS</b> ● Ensure all fasteners are secure.	X			X
<b>ARMS - (PROCEDURE 4)</b> ● Secure but easy to release; adjustment levers engage properly. ● Adjustable height arms operate and lock securely.	X X			X X
<b>FLIP BACK ARMRESTS - (PROCEDURE 4)</b> ● Do not interfere with tires when rolling. ● Pivot points free of wear and looseness.	X X		X X	
<b>SEAT AND BACK UPHOLSTERY</b> ● Inspect for rips or sagging.	X			X
<b>CAPTAIN'S SEAT</b> ● Captain's Seat is secured to the wheelchair frame. ● Remove Captain's Seat quick release pins and inspect. Replace if any signs of wear. ● HIGH BACK CAPTAIN'S SEATS ONLY - Limit switch prevents the wheelchair from operating in any recline position over 114° RELATIVE TO THE SEAT FRAME.  <b>WARNING: NEVER operate the wheelchair while in any recline position over 114° RELATIVE TO THE SEAT FRAME. If the limit switch does not stop the wheelchair from operating in a recline position over 114° RELATIVE TO THE SEAT FRAME, do not operate the wheelchair. Have the wheelchair adjusted by an Invacare dealer or qualified technician.</b>	X X X	X	X	X
<b>DRIVE WHEELS</b> ● Axle bolts and locking tab washers are secure. ● No excessive side movement or binding when lifted and spun when disengaged (free-wheeling).	X X			
<b>FRONT STABILIZERS - MWD WHEELCHAIRS ONLY</b> ● Bolts are tight. ● Adjusted for desired ride. <b>WARNING: MUST be adjusted by a qualified technician.</b>	X X		X	X
<b>CASTERS - (PROCEDURE 8)</b> ● Inspect wheel/fork assembly for proper tension by spinning caster; caster should come to a gradual stop. ● Loosen/tighten locknut if wheel wobbles noticeably or binds to a stop. <b>CAUTION: As with any vehicle, the wheels and tires should be checked periodically for cracks and wear, and should be replaced.</b>	X X		X X	
<b>CASTER/WHEEL/FORK/HEAD TUBE - (PROCEDURE 8)</b> ● Ensure all fasteners are secure.	X	X		
<b>TIRES - (PROCEDURE 8)</b> ● Inspect for flat spots and wear. ● If pneumatic tires check for proper inflation. <b>CAUTION: As with any vehicle, the wheels and tires should be checked periodically for cracks and wear, and should be replaced.</b>	X X	X X		
<b>BATTERIES- (PROCEDURE 10)</b> ● Check for cracks and wear on terminal caps and battery clamp covers. ● Check that terminal caps and battery clamp covers are properly secured to the battery terminals.	X			X
<b>CLEANING</b> ● Clean upholstery and armrests.	X			X

*NOTE: Every six (6) months take your wheelchair to a qualified dealer for a thorough inspection and servicing. Regular cleaning will reveal loose or worn parts and enhance the smooth operation of your wheelchair. To operate properly and safely, your wheelchair must be cared for just like any other vehicle. Routine maintenance will extend the life and efficiency of your wheelchair.*

<p><b>This Procedure Includes the Following:</b></p> <p><i>Installing/Removing Footrests</i></p> <p><i>Adjusting Footrest Height</i></p> <p><i>Replacing Heel Loops</i></p> <p><i>Installing/Removing Elevating Legrests</i></p> <p><i>Raising/Lowering Elevating Legrests and/or Adjusting Calfpads</i></p> <p><i>Adjusting/Replacing Telescoping Front Rigging Support</i></p> <p><i>Adjusting Removable Footboard</i></p>
--

**WARNING**

After ANY adjustments, repair or service and BEFORE use, make sure all attaching hardware is tightened securely - otherwise injury or damage may result.

*NOTE: Some footrests may require the use of two (2) hands to install/remove from the wheelchair.*

**INSTALLING/REMOVING FOOTRESTS (FIGURE 1)**

**Installing**

1. Turn the footrest to the side (open footplate is perpendicular to wheelchair) and position the mounting holes in the footrest hinge plates with the hinge pins on the wheelchair frame.
2. Install the footrest hinge plates onto the hinge pins on the wheelchair frame.
3. Push the footrest towards the inside of the wheelchair until it locks into place.

*NOTE: The footplate will be on the inside of the wheelchair when locked in place.*

4. Repeat STEPS 1-3 for opposite side of wheelchair.

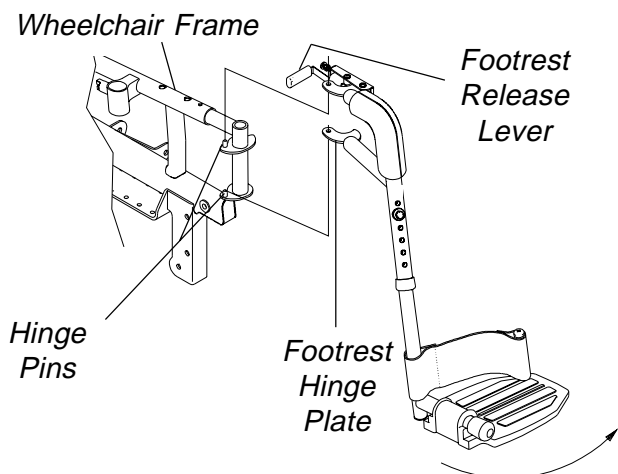

**FIGURE 1 - INSTALLING/REMOVING FOOTRESTS**

**Removing**

1. Push the footrest release lever inward and rotate the footrest outward.
2. Lift up on the footrest and remove from the wheelchair.
3. Repeat STEPS 1-2 for the opposite side of the wheelchair.

**ADJUSTING FOOTREST HEIGHT**

**All Footrests Except Model P93M Footrests (FIGURE 2)**

1. Remove any accessory from the footrest(s).
2. Remove the footrest from the wheelchair. Refer to INSTALLING/REMOVING FOOTRESTS in this procedure of the manual.

*NOTE: Lay the footrest on a flat surface to simplify this procedure.*

3. Remove the hex bolt, coved washers and locknut that secure the lower footrest to the footrest support.
4. Reposition the lower footrest to the desired height.
5. Reinstall the hex bolt, coved washers and locknut that secure the lower footrest to the footrest support and tighten securely.
6. Repeat STEPS 1-5 for the opposite side of the wheelchair footrest, if necessary.
7. Reinstall the footrest(s) onto the wheelchair. Refer to INSTALLING/REMOVING FOOTRESTS in this procedure of the manual.
8. Reinstall any accessory onto the footrest(s).

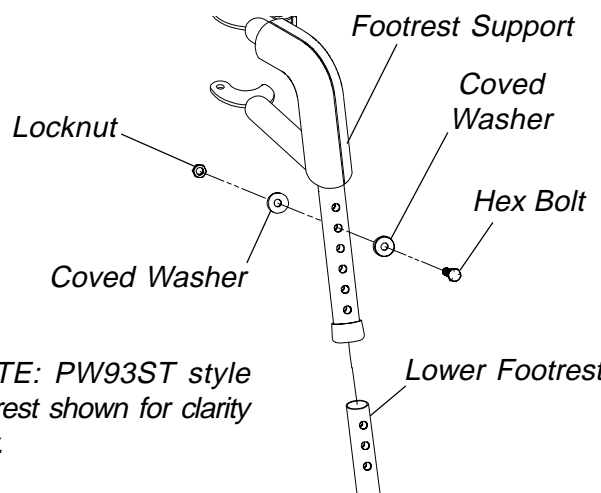

*NOTE: PW93ST style footrest shown for clarity only.*

**FIGURE 2 - ADJUSTING FOOTREST HEIGHT - ALL FOOTRESTS EXCEPT MODEL P93M FOOTRESTS**

**P93M Model Footrests (FIGURE 3)**

1. Loosen, but do not remove the lug bolt and locknut that secure the lower footrest to the footrest support.
2. Reposition the lower footrest to the desired height.
3. Securely tighten the lug bolt and locknut that secure the lower footrest to the footrest support.
4. Repeat STEPS 1-3 for the opposite side of the wheelchair footrest, if necessary.

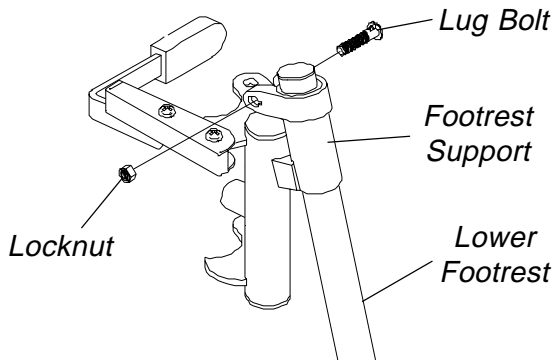

FIGURE 3 - ADJUSTING FOOTREST HEIGHT - P93M MODEL FOOTRESTS

**REPLACING HEEL LOOPS (FIGURE 4)**

1. Note the position of the hex bolt, covered washers and locknut for reinstallation.
2. Remove the hex bolt, covered washers and locknut that secure the lower footrest to the footrest support.
3. Remove the lower footrest.
4. Remove the phillips bolt, spacer and locknut that secure the existing heel loop to the lower footrest.
5. Slide the existing heel loop off the lower footrest.
6. Replace heel loop.
7. Reverse STEPS 1-6 to reassemble.

*NOTE: When securing the heel loop to the lower footrest, tighten the phillips screw and locknut until spacer is secure.*

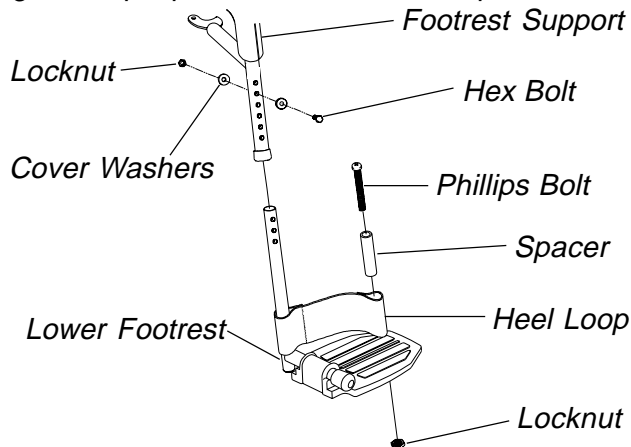

FIGURE 4 - REPLACING HEEL LOOPS

**INSTALLING/REMOVING ELEVATING LEGRESTS (FIGURE 5)**

*NOTE: On RANGER II<sub>JR</sub> Models, the Elevating Legrests MUST be elevated to install/remove from the wheelchair.*

**Installing**

1. Turn the legrest to the side (open footplate is perpendicular to wheelchair) and position the mounting holes in the legrest hinge plates with the hinge pins on the wheelchair frame.
2. Install the legrest hinge plates onto the hinge pins on the wheelchair frame.
3. Rotate legrest toward the inside of the wheelchair until it locks in place.

*NOTE: The footplate will be on the inside of the wheelchair when locked in place.*

4. Repeat STEPS 1-3 for the opposite legrest.
5. After seated in wheelchair, adjust footplate to correct height by loosening the nut and sliding the lower footrest assembly up or down until desired height is achieved.

**Removing**

1. Push the legrest release handle toward the inside of the wheelchair (facing the front of the wheelchair) and swing the legrest to the outside of the wheelchair.
2. Lift up on the legrest and remove from the wheelchair.
3. Repeat STEPS 1-2 for the opposite side of the wheelchair.

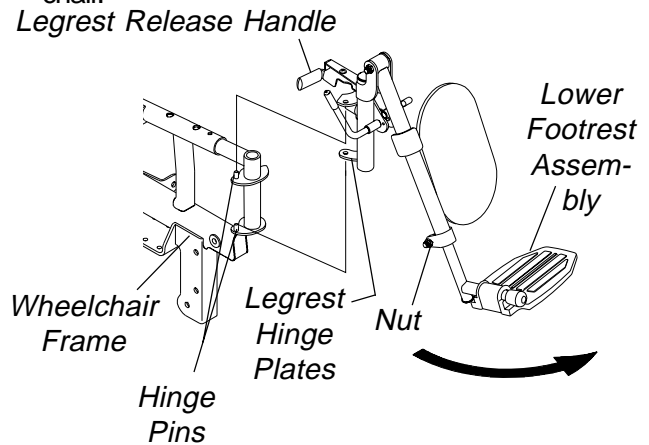

FIGURE 5- INSTALLING/REMOVING ELEVATING LEGRESTS

## RAISING/LOWERING ELEVATING LEGRESTS AND/OR ADJUSTING CALFPADS (FIGURE 6)

### Raising/Lowering Elevating Legrests

- Perform one (1) of the following:
  - RAISING - Pull back on the release lever until the leg is at the desired height.
  - LOWERING - Support leg with one (1) hand and push release lever downward with other hand.

### Adjusting Calfpads

- Turn calfpad towards the outside of the wheelchair.
- Slide the calfpad up or down until the desired position is obtained.

*NOTE: If one (1) of the top two (2) calfpad adjustment positions is being used, the legrest will need to be raised to avoid interference with the front stabilizers while going over obstacles or going up and down ramps. Refer to RAISING/LOWERING ELEVATING LEGRESTS in this procedure of the manual.*

- Turn the calfpad towards the inside of the wheelchair.

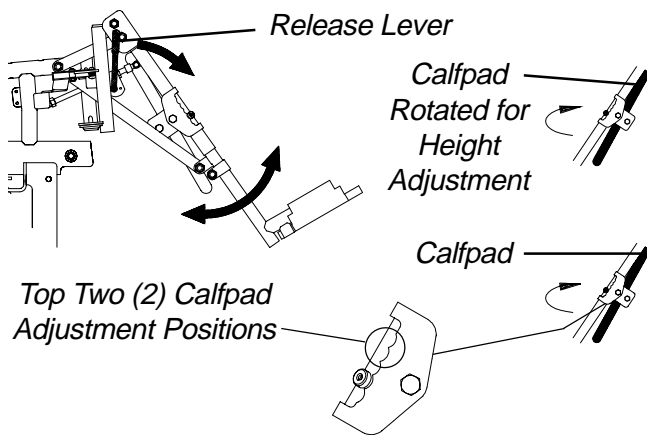

FIGURE 6- RAISING/LOWERING ELEVATING LEGRESTS AND/OR ADJUSTING CALFPADS

## ADJUSTING/REPLACING TELESCOPING FRONT RIGGING SUPPORT (FIGURE 7)

- Lift up on the crossbraces until they release from the H-blocks on the wheelchair frame.
- Remove the phillips bolt and locknut that secure the front H-block to the wheelchair frame.

- Remove the two (2) locknuts and socket bolts that secure telescoping front rigging support to wheelchair.
- If necessary, remove the hex bolt and locknut that secures the battery charger connector bracket to the wheelchair.

### Adjusting

- Position the telescoping front rigging support to the desired depth.

*NOTE: The footplate will be on the inside of the wheelchair when locked in place.*

- Insert front socket bolt into wheelchair frame and mounting hole in the telescoping front rigging support determined in STEP 1 and securely tighten with the locknut.
- Insert the rear socket bolt through the wheelchair frame and the telescoping front rigging support and securely tighten with the locknut.
- Resecure the front H-block to the wheelchair with the phillips bolt and locknut.
- If necessary, resecure the battery charger connector bracket to the wheelchair with the two (2) hex bolts and locknuts.
- Snap crossbraces into H-blocks. Wiggle crossbraces to make sure they are secured in the H-blocks.

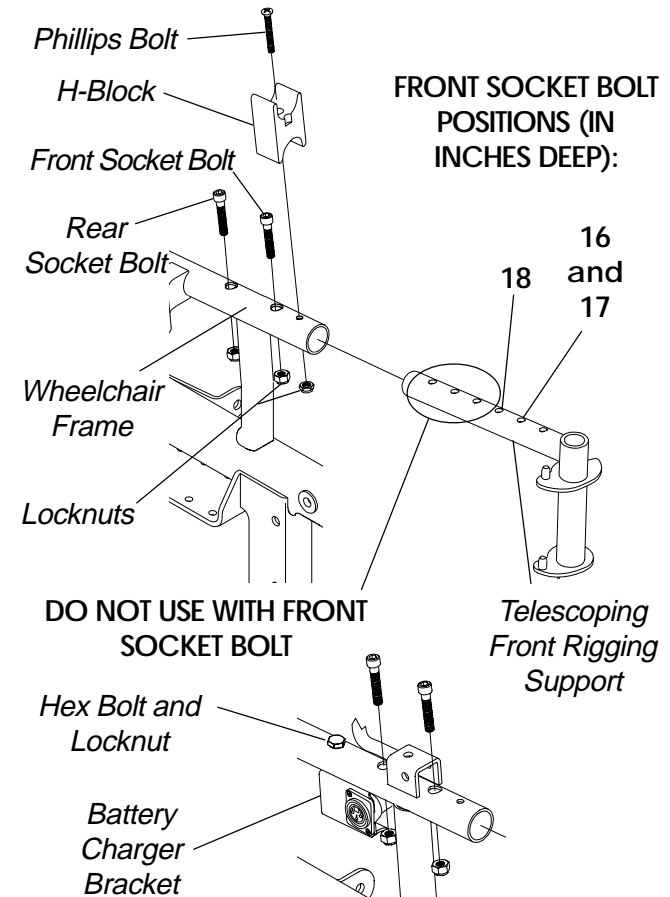

FIGURE 7 - ADJUSTING/REPLACING TELESCOPING FRONT RIGGING SUPPORT

**Replacing**

*NOTE: Observe the position of the current telescoping front rigging support before removal to ensure correct position of new support assembly.*

1. Remove the existing telescoping front rigging support from the wheelchair.
2. Install the new telescoping front rigging support into the wheelchair.
3. Adjust the telescoping front rigging support. Refer to ADJUSTING TELESCOPING FRONT RIGGING SUPPORT in this procedure of the manual.

**ADJUSTING REMOVABLE FOOTBOARD**

**Depth - All Models (FIGURE 8)**

1. Remove the four (4) flat head screws and barrel nuts that secure the removable footboard to the two (2) footplate clamps.

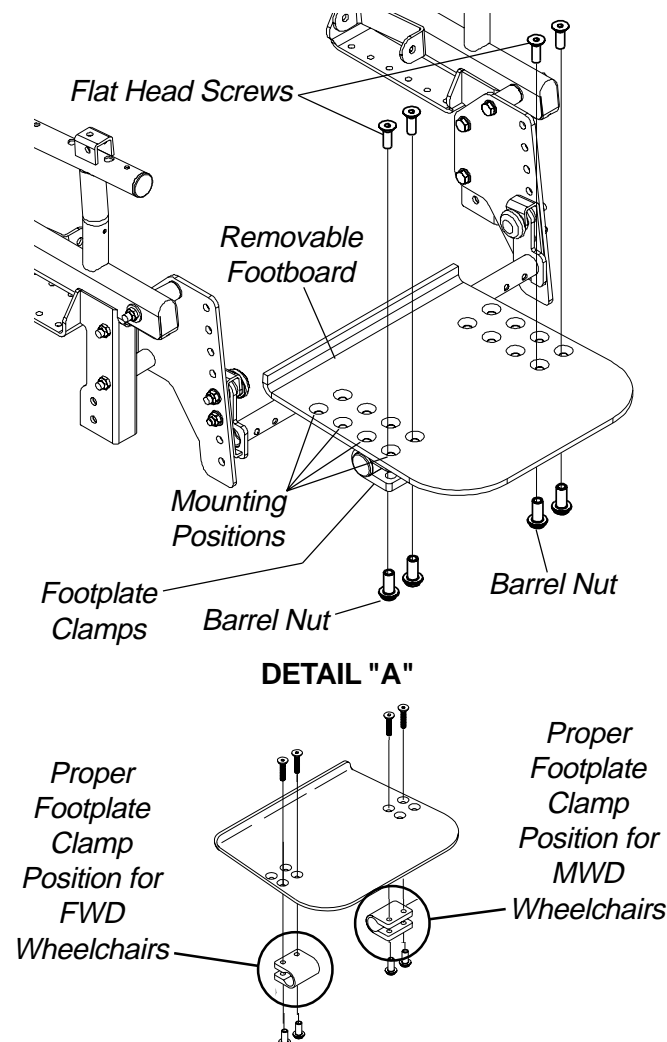

**FIGURE 8 - ADJUSTING FLIP-UP REMOVABLE FOOTBOARD - DEPTH**

2. Move the removable footboard to one (1) of the four (4) positions.

*NOTE: Before reinstalling the four (4) flat head screws, make sure the footplate clamps are in the proper position as shown in DETAIL "A".*

3. Reinstall the four (4) flat head screws and barrel nuts that secure the removable footboard to the two (2) footplate clamps. Tighten securely.

**Angle**

**ADJUSTING FOOTBOARD ANGLE - ALL MODELS (FIGURE 9).**

1. Loosen, but do not remove, the four (4) flat head screws and barrel nuts that secure the removable footboard to the two (2) footplate clamps.

*NOTE: Because of the two (2) support tubes, the angle of the removable footboard can be adjusted downward ONLY.*

2. Grasp the front of the removable footboard and rotate it DOWNWARD until the desired angle is reached.
3. While holding the removable footboard in place, tighten the four (4) flat head screws and barrel nuts securely.

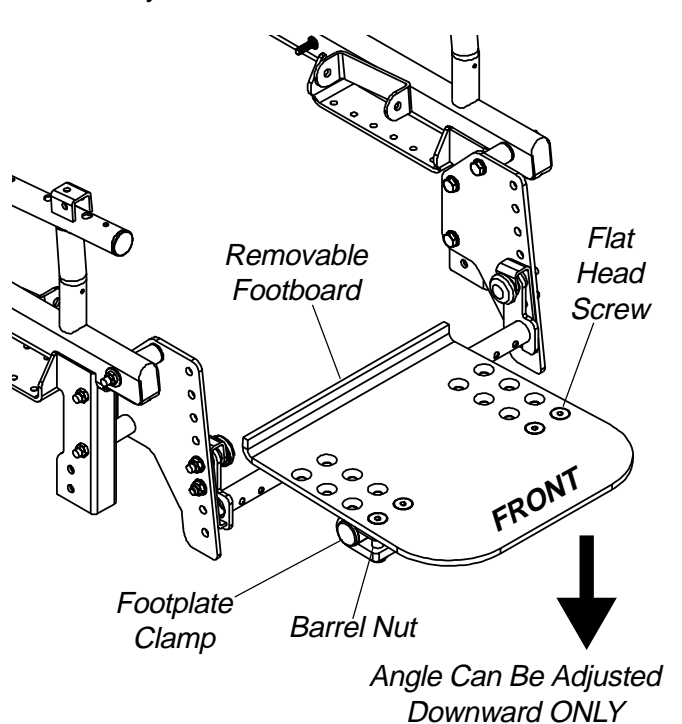

**FIGURE 9 - ADJUSTING FLIP-UP REMOVABLE FOOTBOARD - ADJUSTING FOOTBOARD ANGLE**



### ADJUSTING FOOTBOARD MOUNTING BRACKET ANGLE - FWD MODELS ONLY (FIGURE 10).

*NOTE: This procedure applies to FWD wheelchair models only.*

*NOTE: Angle availability is limited when the motors are in the forward-most position.*

1. Remove the caplug cap.
2. Remove the front hex screw and caplug washer that secure the footboard mounting bracket and bushing to the wheelchair.
3. Repeat STEPS 1-2 for the opposite footboard mounting bracket.
4. Move the footboard mounting brackets to one (1) of three (3) positions.

*NOTE: To ensure the existing hex screws tighten securely, apply Loctite 242 onto the threads.*

5. Reinstall the two (2) hex screws and caplug washers through the two (2) footboard mounting brackets and bushings and into the wheelchair.
6. Torque the two (2) hex screws to 13-ft/lbs.
7. Reinstall the two (2) caplug caps.

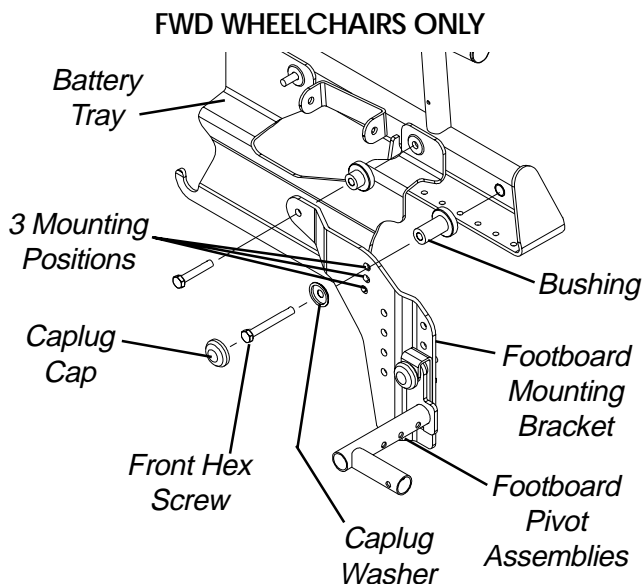

**FIGURE 10 - ADJUSTING REMOVABLE FOOTBOARD - ADJUSTING FOOTBOARD MOUNTING BRACKET ANGLE**

### ADJUSTING THE REMOVABLE FOOTBOARD HEIGHT (FIGURE 11)

1. Remove the removable footboard plate. Refer to REMOVING/INSTALLING THE REMOVABLE FOOTBOARD ONTO/FROM THE WHEELCHAIR in PROCEDURE 3 of the Owner's Manual.
2. Remove the caplug cap.
3. Remove the mounting screw, caplug washer, flat washer and nut that secures the two (2) large washers and support tube to the height adjustment bracket and footboard bracket. Refer to DETAIL "A".
4. Remove the nut, flat washer and that secure the threaded arm on the height adjustment bracket to the footboard bracket. Refer to DETAIL "B".
5. Perform one (1) of the following:
  - A. **MWD WHEELCHAIRS** - Move the height adjustment bracket to one (1) of seven (7) height positions.
  - B. **FWD WHEELCHAIRS** - Move the height adjustment bracket to one (1) of five (5) height positions.
6. Reinstall the flat washer and nut that secures the threaded arm on the height adjustment bracket to the footboard bracket. Refer to DETAIL "B".
7. Reinstall the mounting screw, caplug washer, flat washer and nut that secures the two (2) large washers and support tube to the height adjustment bracket and footboard bracket. Refer to DETAIL "A".
8. Reinstall the caplug caps.
9. Repeat STEPS 2-8 for the opposite footboard bracket.
10. Reinstall the removable footboard plate. Refer to REMOVING/INSTALLING THE REMOVABLE FOOTBOARD ONTO/FROM THE WHEELCHAIR in PROCEDURE 3 of the Owner's Manual.

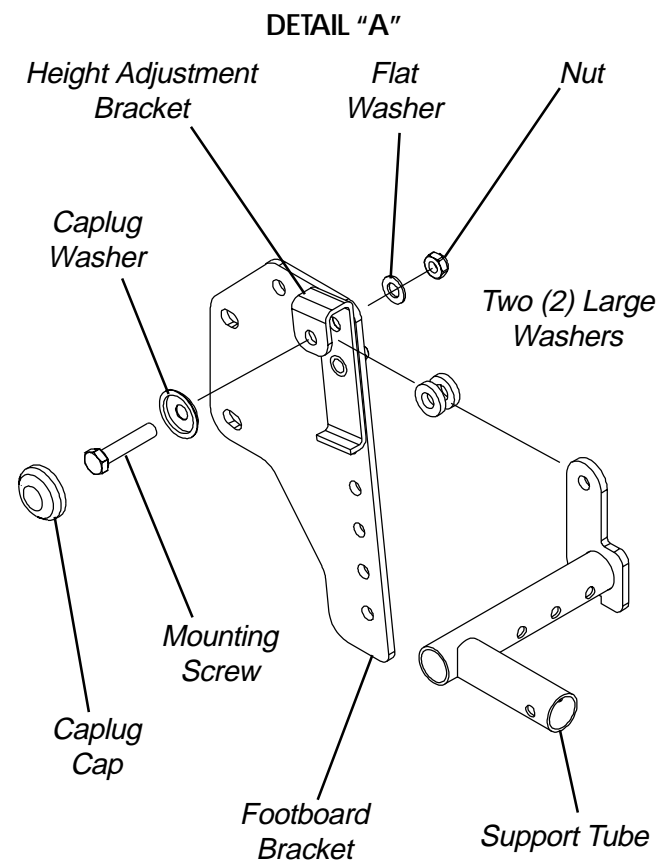

DETAIL "B"

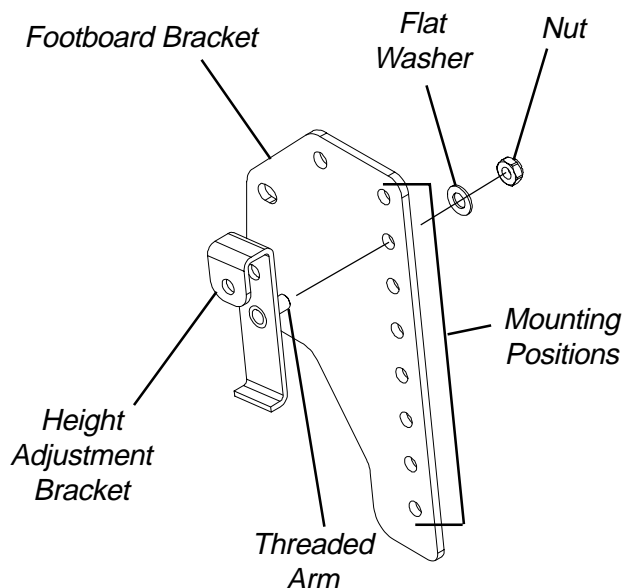

*NOTE: Only MWD footboard bracket shown for clarity. The footboard bracket on the FWD model adjusts in the same manner.*

**FIGURE 11 - ADJUSTING THE REMOVABLE FOOTBOARD HEIGHT**

**PREPARING REMOVABLE FOOTBOARD FOR WHEELCHAIR TRANSPORTATION (FIGURE 12)**

**Removing The Removable Footboard Plate**

1. Depress the push pins on the two (2) support tubes on the removable footboard plate.
2. While performing STEP 1, grasp the removable footboard plate and pull it away from the two (2) support tubes on the removable footboard mounting brackets.

**Installing The Removable Footboard Plate**

1. Align the two (2) support tubes on the removable footboard plate with the two (2) support tubes on the removable footboard mounting brackets.
2. Push the two (2) support tubes on the removable footboard plate onto the two (2) support tubes on the removable footboard mounting brackets, until the push pins release into the adjustment holes.

**WARNING**

**Make sure the push pins are fully protruding through the adjustment holes BEFORE using the wheelchair. Otherwise, injury or damage can occur.**

3. Make sure the push pins are completely released.

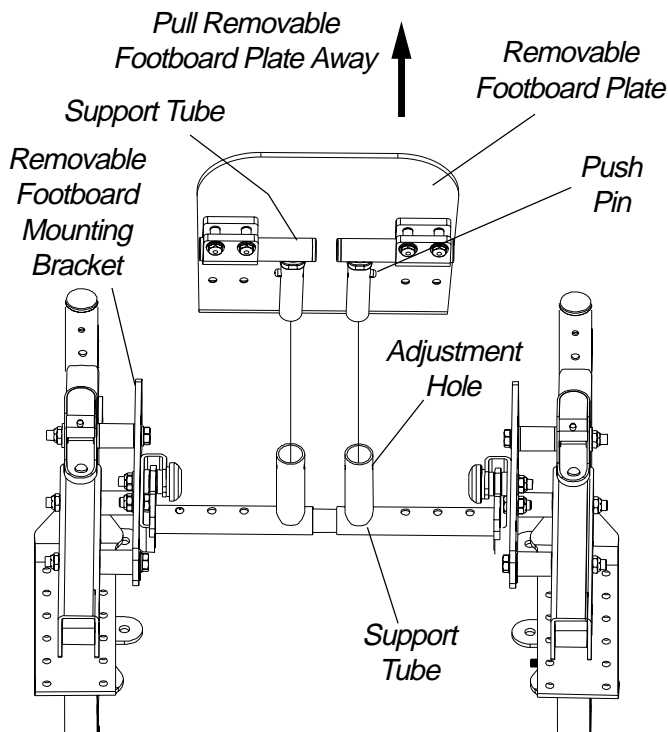

*NOTE: Bottom view of wheelchair/footboard shown for clarity.*

**FIGURE 12 - PREPARING REMOVABLE FOOTBOARD FOR WHEELCHAIR TRANSPORTATION**

**This Procedure Includes the Following:**  
**Installing/Removing Flip Back Armrests**  
**Adjusting Flip Back Armrests**  
**Adjusting Captain's Seat Armrests**

**WARNING**  
 After ANY adjustments, repair or service and BEFORE use, make sure all attaching hardware is tightened securely - otherwise injury or damage may result.

**INSTALLING/REMOVING FLIP BACK ARMRESTS (FIGURE 1)**

*NOTE: Flip back armrests are available on integrated sling seat model wheelchairs only.*

**WARNING**  
 Make sure the flip back armrest release and height adjustment levers are in the locked position before using the wheelchair.

*NOTE: Flip back armrest release lever must be in unlocked position when placing armrest into the arm sockets.*

**Installing**

1. Slide the flip back armrest into the arm sockets on the wheelchair frame.
2. Install the quick release pin through the rear arm socket and flip back armrest.

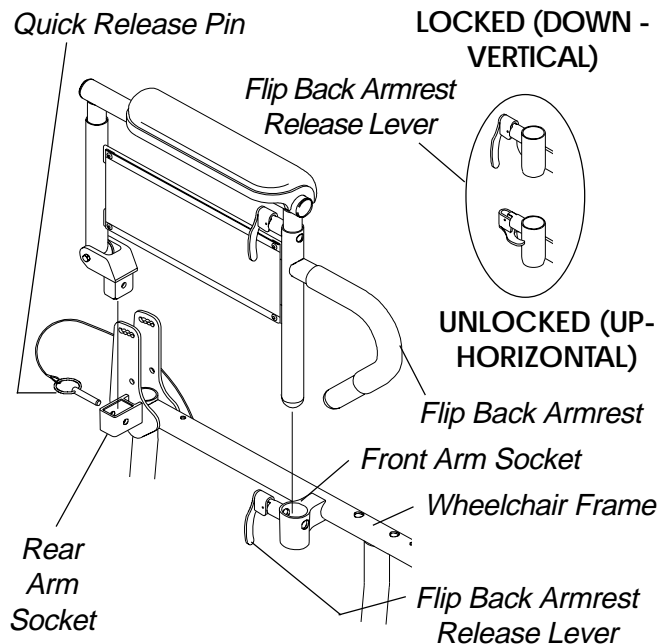

**FIGURE 1 - INSTALLING/REMOVING FLIP BACK ARMRESTS**

3. Lock flip back armrest by pressing flip back armrest release lever into the DOWN (VERTICAL) position.
4. Lift up on flip back armrest to make sure the armrest is locked in place.
5. Repeat STEPS 1-4 for opposite flip back armrest.

**Removing**

1. Unlock flip back armrest by pulling flip back armrest release lever into the UP (HORIZONTAL) position.
2. Remove the quick release pin that secures the flip back armrest to the wheelchair frame.
3. Pull up on the flip back armrest and remove the armrest from the arm sockets.
4. Repeat STEPS 1-3 for the opposite flip back armrest, if necessary.

**ADJUSTING FLIP BACK ARMRESTS (FIGURE 2)**

*NOTE: Flip back armrests are available on integrated sling seat model wheelchairs only.*

**Positioning Flip Back Armrests for User Transfer**

1. Unlock the flip back armrest by pulling the armrest release lever into the UP (HORIZONTAL) position.
2. Pull up on the flip back armrest and remove the armrest from the front arm socket.
3. Continue to pull up on the flip back armrest until the armrest is out of the way.
4. Repeat STEPS 1-3 for opposite flip back armrest, if necessary.

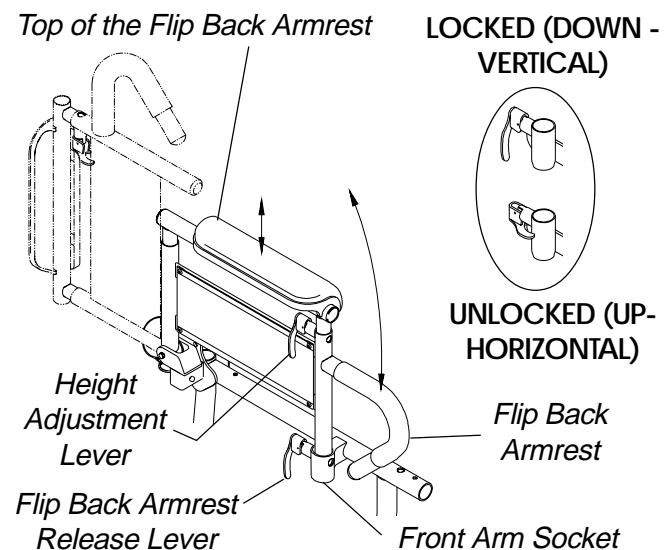

**FIGURE 2 - ADJUSTING FLIP BACK ARMRESTS**

**Positioning Flip Back Armrests for Use**

1. Make sure the flip back armrest release lever is in the UP (HORIZONTAL) position.
2. Install the flip back armrest into the front arm socket.
3. Lock flip back armrest by pressing flip back armrest release lever into the DOWN (VERTICAL) position.
4. Lift up on flip back armrest to make sure the armrest is locked in place.
5. Repeat STEPS 1-4 for opposite flip back armrest, if necessary.

**Adjusting**

1. Unlock top of flip back armrest by pulling height adjustment lever into the UP (HORIZONTAL) position.
2. Adjust top of the flip back armrest to the desired height.
3. Lock top of flip back armrest by pushing height adjustment lever into the DOWN (VERTICAL) position.
4. Lift up on flip back armrest to make sure the armrest is locked in place.
5. Repeat STEPS 1-4 for opposite flip back armrest, if necessary.

6. Repeat STEPS 1-5 for opposite armrest, if necessary.

**Height (FIGURE 4)**

1. Remove the socket screw that secures the armrest to the seat frame assembly.
2. Adjust the armrest to one (1) of four (4) positions.
3. Reinstall the socket screw that secures the armrest to the seat frame assembly and tighten securely.

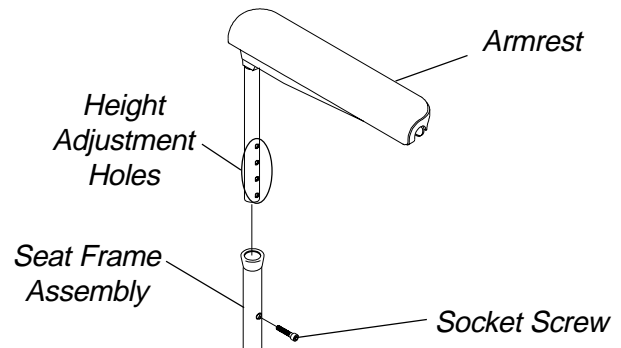

FIGURE 4 - ADJUSTING CAPTAIN'S SEAT ARMRESTS - HEIGHT

**ADJUSTING CAPTAIN'S SEAT ARMRESTS**

**Angle (FIGURE 3)**

1. Lift-up the armrest.
2. Loosen the jam nut.
3. Adjust the socket screw up or down to the desired arm angle position.
4. Tighten the jam nut.
5. To determine the same angle for the opposite armrest, count the exposed threads after the jam nut has been tightened.

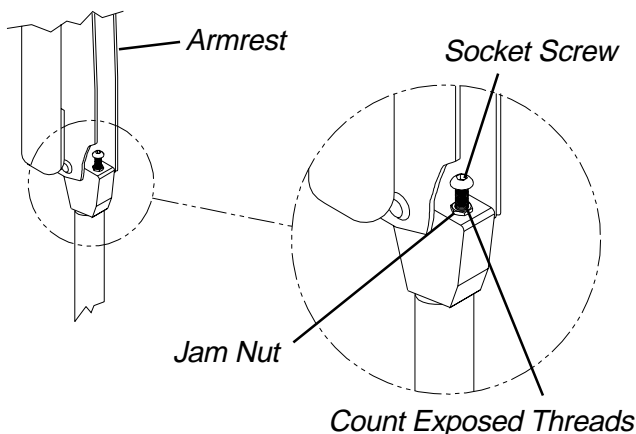

FIGURE 3 - ADJUSTING CAPTAIN'S SEAT ARMRESTS - ANGLE

*This Procedure Includes the Following:*

*Replacing Seat Upholstery*

*Adjusting Captain's Seat*

*Removing/Installing Captain's Seat*

*Replacing Seat Positioning Strap*

**WARNING**

After ANY adjustments, repair or service and BEFORE use, make sure all attaching hardware is tightened securely - otherwise injury or damage may result.

**REPLACING SEAT UPHOLSTERY (FIGURE 1)**

*NOTE: Seat upholstery is available on integrated sling seat model wheelchairs only.*

1. Remove the eight (8) phillips screws and washers that secure the existing seat upholstery to the cross-braces.
2. Remove existing seat upholstery from the cross-braces.
3. Line up mounting holes in new seat upholstery with mounting holes in the crossbraces.
4. Securely tighten with existing phillips screws and washers.

*NOTE: Clean upholstery with warm DAMP cloth and mild detergent to remove superficial soil.*

**WARNING**

Laundrying or moisture will reduce flame retardation of the upholstery.

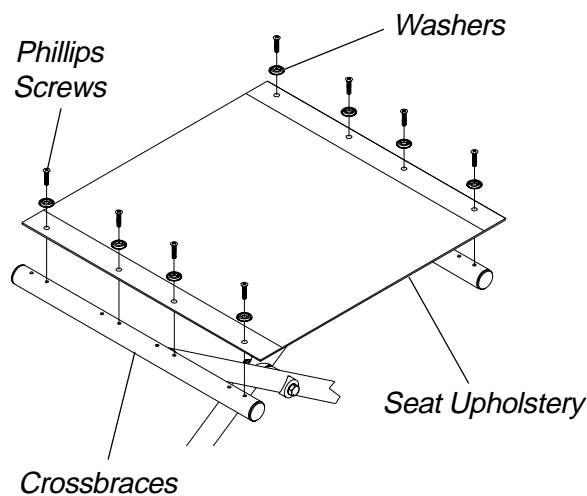

FIGURE 1 - REPLACING SEAT UPHOLSTERY

**ADJUSTING CAPTAIN'S SEAT (FIGURE 2)**

**Low Back Captain's Seats**

1. Lift up on the release handle and move the back to the desired position.

**High Back Captain's Seats**

**ANGLE.**

**WARNING**

HIGH BACK CAPTAIN'S SEATS ONLY - NEVER operate the wheelchair while in any recline position over 114° RELATIVE TO THE SEAT FRAME. If the limit switch does not stop the wheelchair from operating in a recline position greater than 114° RELATIVE TO THE SEAT FRAME, do not operate the wheelchair. Have the wheelchair serviced by an authorized Invacare dealer or qualified technician.

1. Lift up on the release handle and move the back to the desired position.
2. Check the angle of the back RELATIVE TO THE SEAT FRAME.
3. If necessary, have the limit switch adjusted. Contact an authorized Invacare dealer or qualified technician.

**LUMBAR.**

1. Rotate the knob on the side of the high back Captain's Seat COUNTERCLOCKWISE until the desired support is obtained.

*NOTE: The knob only rotates COUNTERCLOCKWISE.*

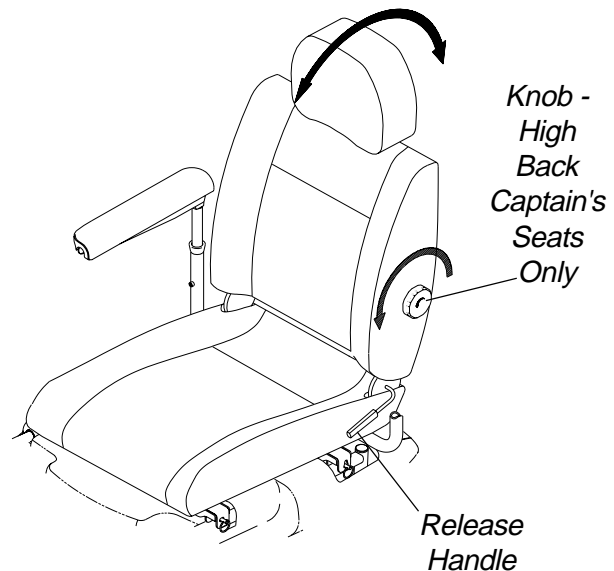

FIGURE 2 - ADJUSTING CAPTAIN'S SEAT

UPHOLSTERY

CAPTAIN'S SEAT

POSITIONING STRAP

### REMOVING/INSTALLING CAPTAIN'S SEAT (FIGURE 3)

#### Removing

1. Turn the adjustment lock lever to release the joystick mounting tube from the armrest.
2. Remove the joystick from the wheelchair.
3. **HIGH BACK CAPTAIN'S SEATS ONLY** - Disconnect the limit switch. Refer to DISCONNECTING/CONNECTING LIMIT SWITCH in PROCEDURE 6 of this manual.
4. Remove the four (4) quick release pins that secure the Captain's Seat to the wheelchair frame.
5. Remove the Captain's Seat from the wheelchair.

#### Installing

1. Push the Captain's Seat down on the wheelchair frame at the position shown in FIGURE 3.
2. Line up the mounting holes in the Captain's Seat and the wheelchair frame.

#### WARNING

Make sure the Captain's Seat is secured to the wheelchair frame with the four (4) quick release pins BEFORE using the wheelchair, otherwise injury or damage can occur.

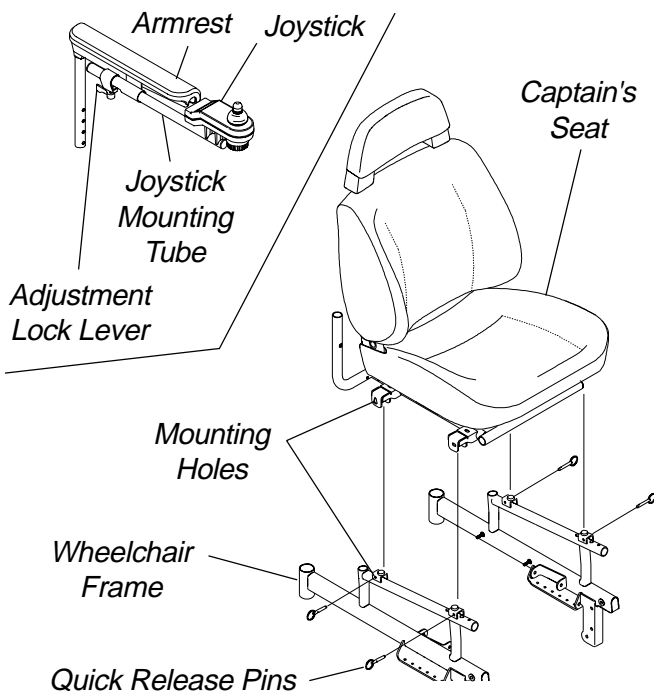

FIGURE 3- REMOVING/INSTALLING CAPTAIN'S SEAT

3. Insert the four (4) quick release pins through the mounting holes in the Captain's Seat and the wheelchair frame until the rings on the quick release pins are against the mounting holes.
4. Lift up on the Captain's Seat to make sure it is secured to the wheelchair frame.
5. **HIGH BACK CAPTAIN'S SEATS ONLY** - Connect the limit switch. Refer to DISCONNECTING/CONNECTING LIMIT SWITCH in PROCEDURE 6 of this manual.
6. Slide the joystick into the adjustment lock lever to the desired position.
7. Turn the adjustment lock lever to secure the joystick mounting tube to the armrest.

### REPLACING SEAT POSITIONING STRAP

#### Integrated Sling Seat Models (FIGURE 4)

1. If necessary, remove the seat cushion from the seat upholstery.
  2. Remove the two (2) rear phillips screws and washers that secure the seat upholstery and existing seat positioning strap to the crossbraces.
  3. Remove the two (2) halves of the seat positioning strap from the crossbraces.
  4. Position the two (2) new seat positioning strap halves between the seat upholstery and the crossbraces.
  5. Reinstall the rear phillips screws and washers that secure the seat upholstery and seat positioning strap to the crossbraces.
- NOTE: Washer is positioned on top of seat upholstery.*
6. If necessary, reinstall seat cushion onto seat upholstery.

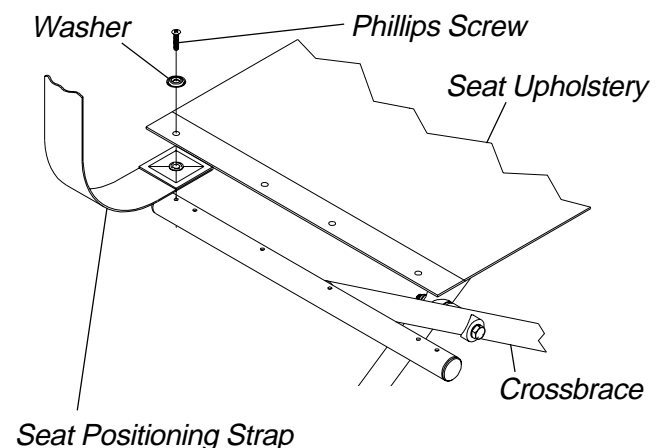

FIGURE 4 - REPLACING SEAT POSITIONING STRAP - INTEGRATED SLING SEAT MODELS

**This Procedure Includes the Following:****Preparing MKIV Joystick for Use****Repositioning MKIV Joystick****Disconnecting/Connecting Limit Switch****Repositioning Battery Charger Connector****Fuse Replacement****WARNING**

After ANY adjustments, repair or service and BEFORE use, make sure all attaching hardware is tightened securely - otherwise injury or damage may result.

**PREPARING MKIV JOYSTICK FOR USE (FIGURE 1)**

*NOTE: The MKIV joystick is factory installed on the right side of the wheelchair. To reposition the MKIV joystick onto the left side of the wheelchair, perform one (1) of the following: **INTEGRATED SLING SEAT WHEELCHAIRS - REPOSITIONING MKIV JOYSTICK** in this procedure of the manual or **CAPTAIN'S SEAT MODEL WHEELCHAIRS -** have the joystick repositioned by an authorized Invacare dealer or qualified technician.*

1. Turn the lever on the adjustment lock to release the adjustment lock from joystick mounting tube.
2. Slide joystick mounting tube to the desired position.
3. Turn the lever on the adjustment lock to secure the adjustment lock to the joystick mounting tube.

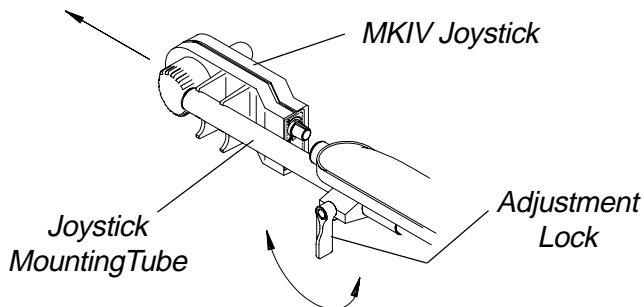

FIGURE 1 - PREPARING MKIV JOYSTICK FOR USE

**REPOSITIONING MKIV JOYSTICK****Integrated Sling Seat Models (FIGURE 2)**

1. Turn the lever on the adjustment lock to release the adjustment lock from joystick mounting tube (**tube**).
2. Remove the joystick from the wheelchair.
3. Remove the three (3) hex screws that secure joystick mounting bracket (**bracket**), the threaded hole half clamp and the opened hole half clamp to the arm tube.

4. Reposition the threaded hole half clamp and opened hole half clamp on the opposite arm tube. Make sure threaded hole half clamp is on the inside of arm tube.
5. While holding the two (2) half clamps, install the front hex screw into the two (2) half clamps. Securely tighten.
6. Line up mounting holes of the joystick mounting bracket with the mounting holes in the two (2) half clamps.
7. Secure the joystick mounting bracket to the two (2) half clamps with the remaining two (2) hex screws.
8. Slide tube through the bracket to the desired position.
9. Slide adjustment lock over end of tube and secure adjustment lock to tube by turning lever on adjustment lock.

*NOTE: If adjustment lock does not fit over tube, rotate 180°.*

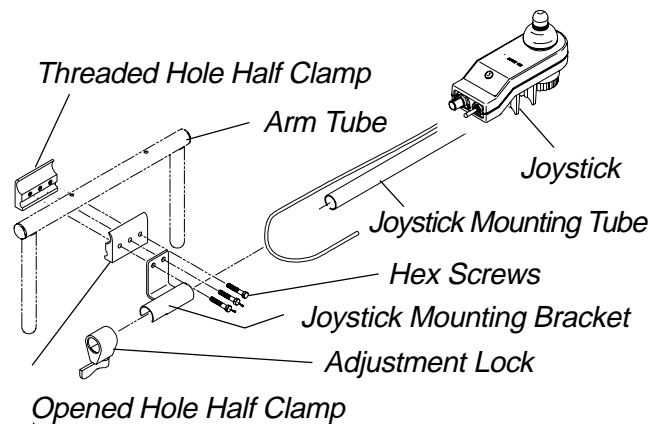

FIGURE 2 - REPOSITIONING MKIV JOYSTICK - INTEGRATED SLING SEAT MODELS

**DISCONNECTING/CONNECTING LIMIT SWITCH (FIGURE 3)**

*NOTE: The following procedure is for High Back Captain's Seat model wheelchairs only.*

**CAUTION**

Disconnect limit switch **BEFORE** removing seat otherwise, damage to switch can occur.

1. Perform one (1) of the following:
    - DISCONNECTING -** While holding body of limit switch phono plug, lift up gently.
- NOTE: When the limit switch is unplugged the wheelchair will NOT operate.*
- CONNECTING -** Plug limit switch plug into the limit switch phono jack.

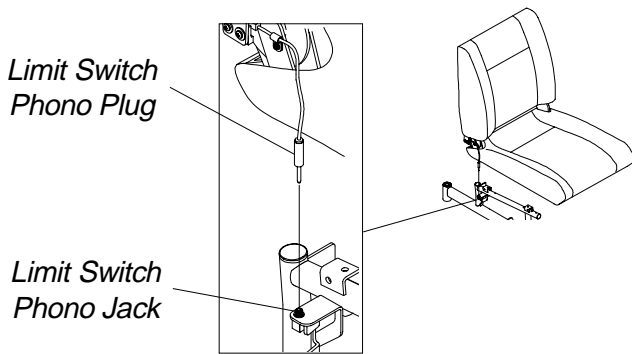

FIGURE 3 - DISCONNECTING/CONNECTING LIMIT SWITCH

**REPOSITIONING BATTERY CHARGER CONNECTOR (FIGURE 4)**

*NOTE: The following procedure applies to FWD wheelchairs that are equipped with MKIV controllers ONLY.*

1. Fold the wheelchair. Refer to TRANSPORTING RANGER II FWD in PROCEDURE 11 of this manual.
2. If necessary, remove the battery charger cover from the filler shroud.
3. Remove the hex bolt and locknut that secures the battery charger connector bracket to the wheelchair.
4. Perform one (1) of the following:

**Battery Charger Connector Cable too Long -**

- A. Reposition the battery charger connector bracket on the opposite side of the wheelchair frame.
- B. Line up the mounting holes in the battery charger connector bracket and the wheelchair frame.
- C. Install the hex bolt through the wheelchair frame and battery charger bracket.
- D. Install the locknut onto the hex bolt and tighten securely.
- E. Tuck the excess battery charger cable into the spiral wire cover on the wiring harness.

**Battery Charger Connector Cable too Short -**

- A. Pull the battery charger cable out of the spiral wire cover on the wiring harness.
  - B. Reposition the battery charger connector bracket on the opposite side of the wheelchair frame.
  - C. Line up the mounting holes in the battery charger connector bracket and the wheelchair frame.
  - D. Install the hex bolt through the wheelchair frame and battery charger bracket.
  - E. Install the locknut onto the hex bolt and tighten securely.
5. If necessary, install the battery charger cover on the opposite filler shroud.
  6. Unfold the wheelchair. Refer to TRANSPORTING RANGER II FWD in PROCEDURE 11 of this manual.

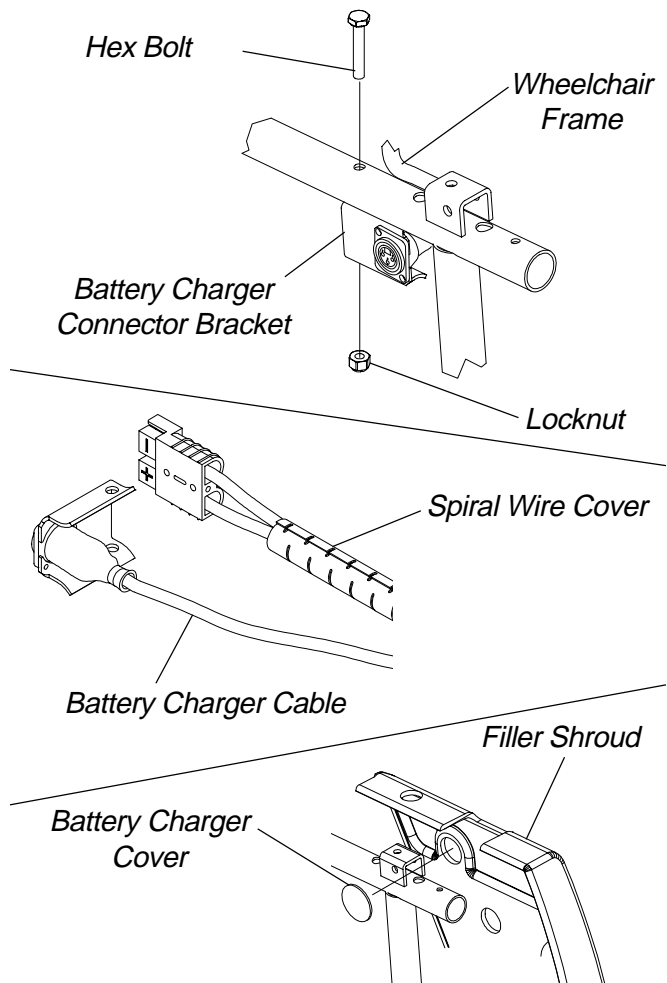

FIGURE 4 - REPOSITIONING BATTERY CHARGER CONNECTOR



## FUSE REPLACEMENT

*NOTE: Fuse found on battery wiring harness for RANGER II<sub>JR</sub> only.*

1. Remove the front shroud. Refer to REMOVING/INSTALLING THE SHROUDS in PROCEDURE 9 of this manual.
2. Remove the front battery. Refer to REMOVING/INSTALLING THE BATTERIES in PROCEDURE 9 of this manual.
3. Remove the existing fuse from fuse holder and install new fuse.
4. Reassemble wheelchair by reversing STEPS 1-2.

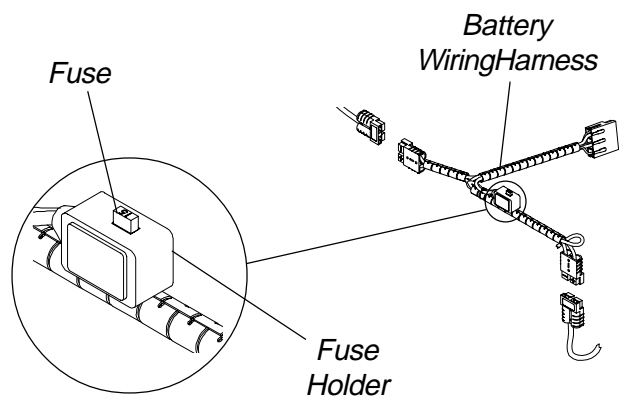

FIGURE 5 - FUSE REPLACEMENT

**This Procedure Includes the Following:**

**Replacing Battery Box Retaining Strap**

**WARNING**

After ANY adjustments, repair or service and BEFORE use, make sure all attaching hardware is tightened securely - otherwise injury or damage may result.

**REPLACING BATTERY BOX RETAINING STRAP**

**All MWD Models and FWD Model RANGER II<sub>JR</sub> (FIGURE 1)**

1. If necessary, remove the front and rear shrouds. Refer to REMOVING/INSTALLING SHROUDS in PROCEDURE 9 of this manual.

2. Remove the battery boxes from the wheelchair. Refer to one (1) of the following:

**FWD WHEELCHAIRS - INSTALLING/REMOVING BATTERY BOXES** in PROCEDURE 11 of this manual.

**MWD WHEELCHAIRS - INSTALLING/REMOVING BATTERY BOXES** in PROCEDURE 12 of this manual.

**WARNING**

The retaining strap **MUST** be fed through the adjustable end of the battery box retaining strap clip as shown in FIGURE 1.

3. Feed the existing battery box retaining strap through the adjustable end of the battery box retaining strap buckle.
4. Feed the existing battery box retaining strap through the slot in the battery box tray.
5. Feed the new battery box retaining strap through the inside of the slot in the battery box tray.
6. Feed the new battery box retaining strap through the adjustable end of the battery box retaining strap buckle.

*NOTE: Strap should have 3/4-inch length minimum beyond buckle.*

7. Install the battery boxes onto the wheelchair. Refer to one (1) of the following:

**FWD WHEELCHAIRS - INSTALLING/REMOVING BATTERY BOXES** in PROCEDURE 11 of this manual.

**MWD WHEELCHAIRS - INSTALLING/REMOVING BATTERY BOXES** in PROCEDURE 12 of this manual.

**WARNING**

The Battery Box Retaining Strap **MUST** be fastened securely and adjusted properly to hold battery boxes in place before using the wheelchair. Otherwise, injury to the user and/or damage to the wheelchair may occur.

8. If necessary, install the front and rear shrouds. Refer to REMOVING/INSTALLING SHROUDS in PROCEDURE 9 of this manual.

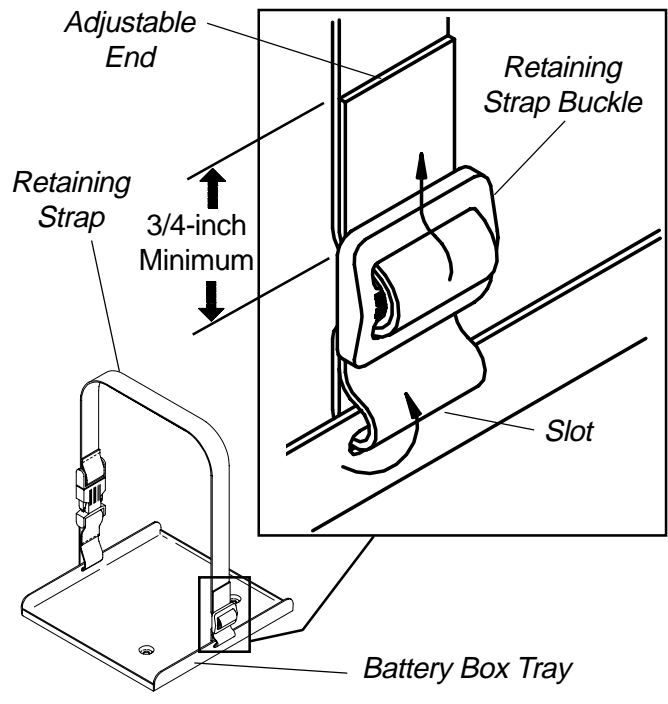

*NOTE: Tray shown by itself for clarity. There is no need to remove the tray from the wheelchair if the retaining strap is being replaced.*

*NOTE: RANGER II<sub>JR</sub> battery tray not shown for clarity. Retaining strap removes/installs in the same manner.*

**FIGURE 1 - REPLACING BATTERY BOX RETAINING STRAP - ALL MWD MODELS AND FWD MODEL - RANGER II<sub>JR</sub>**

**All FWD Models Except RANGER II<sub>JR</sub>**  
**(FIGURE 2)**

1. If necessary, remove the front and rear shrouds. Refer to REMOVING/INSTALLING SHROUDS in PROCEDURE 9 of this manual.
2. Remove the battery boxes from the wheelchair. Refer to INSTALLING/REMOVING BATTERY BOXES in PROCEDURE 11 of this manual.
3. Remove the two (2) hex bolts and locknut that secure the existing battery tray to the tray support.
4. Remove the existing battery tray from the wheelchair.
5. Position the new battery tray on the tray support as shown in FIGURE 2.
6. Secure the new battery tray to the tray support with the two (2) hex bolts and locknuts. Tighten securely.
7. Reinstall the battery boxes. Refer to INSTALLING/REMOVING BATTERY BOXES in PROCEDURE 11 of this manual.
8. If necessary, install the front and rear shrouds. Refer to REMOVING/INSTALLING SHROUDS in PROCEDURE 9 of this manual.

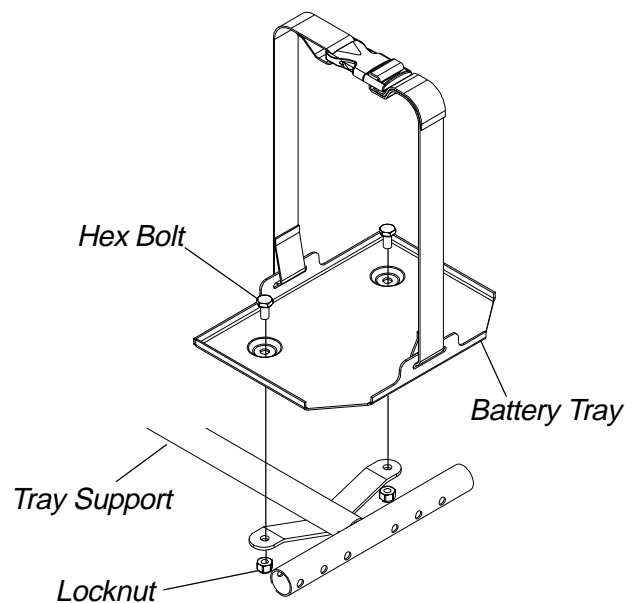

**FIGURE 2 - REPLACING BATTERY BOX RETAINING STRAP - ALL FWD MODELS EXCEPT RANGER II<sub>JR</sub>**

*This Procedure Includes the Following:*  
**Engaging/Disengaging Motors with Clutches**  
**Engaging/Disengaging Motors with Motor Locks**  
**Adjusting Forks**

**WARNING**

After ANY adjustments, repair or service and BEFORE use, make sure all attaching hardware is tightened securely - otherwise injury or damage may result.

**CAUTION**

As with any vehicle, the wheels and tires should be checked periodically for cracks and wear and should be replaced.

**ENGAGING/DISENGAGING MOTORS WITH CLUTCHES (FIGURES 1 AND 2)**

**WARNING**

DO NOT engage or disengage the clutches until the power is in the OFF position.

**CAUTION**

Ensure both clutches are fully engaged BEFORE driving the wheelchair.

1. Locate the clutch handles on motors.
2. Perform one (1) of the following:
  - A. **ENGAGING (FIGURE 1) -**
    1. Push the clutch handle IN.
    2. Push the clutch handle towards the front of the wheelchair.

**ENGAGING:**

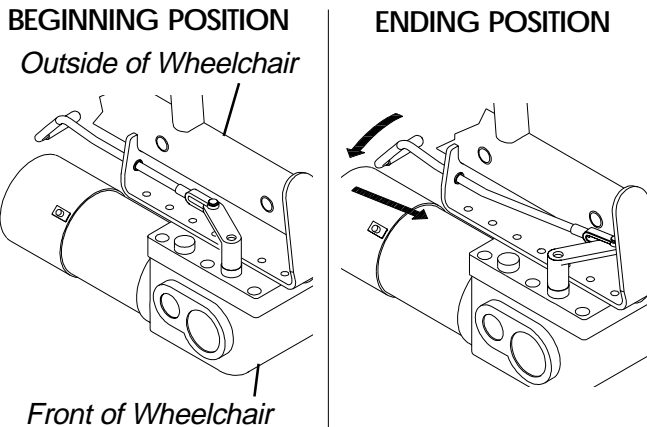

FIGURE 1 - ENGAGING MOTORS WITH CLUTCHES

**B. DISENGAGING (FIGURE 2) -**

1. Pull the clutch handle towards the rear of the wheelchair.
2. Pull the clutch handle OUT.

**DISENGAGING:**

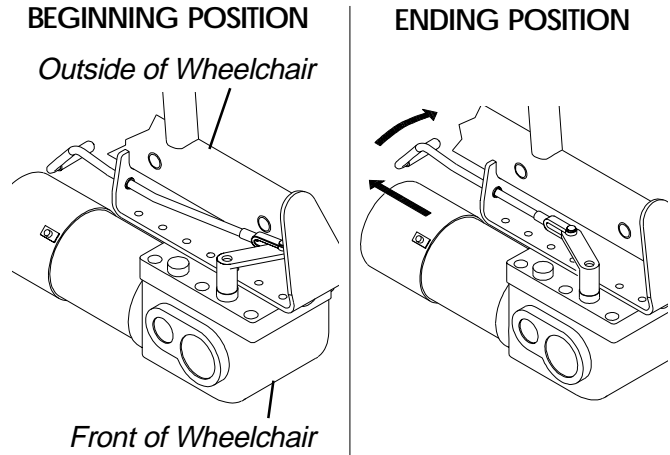

FIGURE 2 - DISENGAGING MOTORS WITH CLUTCHES

**ENGAGING/DISENGAGING MOTORS WITH MOTOR LOCKS (FIGURE 3)**

**WARNING**

DO NOT engage or disengage the motor locks until the power is in the OFF position.

**CAUTION**

Ensure both motor locks are fully engaged BEFORE driving the wheelchair.

The motor lock disengagement/engagement allows free-wheeling or joystick controlled operation. Freewheeling allows an attendant to maneuver the wheelchair without power. To disengage/engage the motor locks:

1. Locate the motor lock levers on the motors.
2. Perform one (1) of the following:
  - A. **DISENGAGE** - Push the motor lock lever until they are pointing towards the outside of the wheelchair (free wheel position).
  - B. **ENGAGE** - Pull the motor lock handles until they are pointing up (drive position).

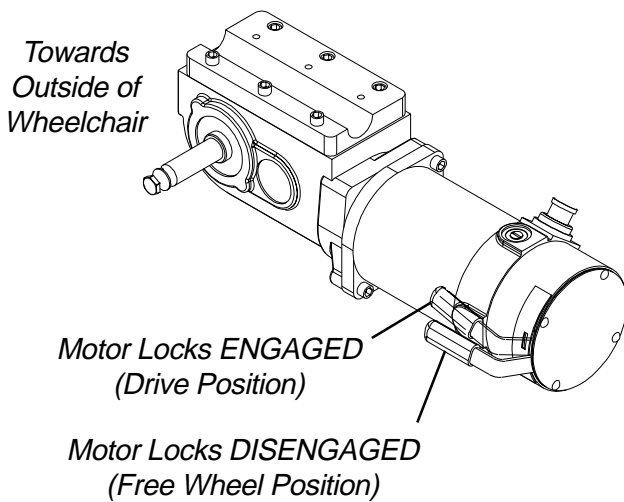

FIGURE 3 - ENGAGING/DISENGAGING MOTORS WITH MOTOR LOCKS

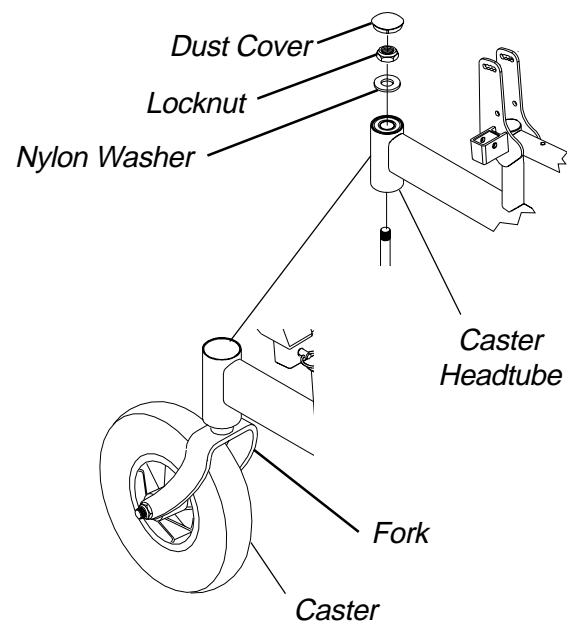

FIGURE 4 - ADJUSTING FORKS

### ADJUSTING FORKS (FIGURE 4)

1. Remove the dust cover from the caster headtube.
2. To properly tighten caster journal system and guard against flutter, perform the following check:
  - A. Tip back the wheelchair to floor.
  - B. Pivot both forks and casters to top of their arc simultaneously.
  - C. Let casters drop to bottom of arc (wheels should swing once to one-side, then immediately rest in a straight downward position).
  - D. Adjust locknuts according to freedom of caster swing.
3. Test wheelchair for maneuverability.
4. Readjust locknuts if necessary, and repeat STEPS 1-3 until correct.
5. Snap dust cover into the caster headtube.

*This Procedure Includes the Following:*

*Removing/Installing Shrouds*

### WARNING

After ANY adjustments, repair or service and BEFORE use, make sure all attaching hardware is tightened securely - otherwise injury or damage may result.

## REMOVING/INSTALLING SHROUDS

### MWD Wheelchairs (FIGURE 1)

#### REMOVING FRONT SHROUD.

1. Turn the two (2) 1/4-turn bolts that secure front shroud to the two (2) side shrouds COUNTERCLOCKWISE.
2. Remove the front shroud from the wheelchair.

#### INSTALLING FRONT SHROUD.

1. Position the two (2) 1/4-turn bolts with the two (2) mounting holes in the side shrouds.
2. Install the front shroud onto the two (2) side shrouds.
3. Turn the two (2) 1/4-turn bolts that secure the front shroud to the two (2) side shrouds CLOCKWISE.

#### REMOVING REAR SHROUD AND REAR STORAGE COMPARTMENT.

1. Lift up on rear shroud and remove from wheelchair.
2. Turn the two (2) 1/4-turn bolts that secure the rear storage compartment to the wheelchair frame COUNTERCLOCKWISE.
3. Remove rear storage compartment from wheelchair.

#### INSTALLING REAR SHROUD AND REAR STORAGE COMPARTMENT.

1. Position the two (2) 1/4-turn bolts with the two (2) mounting holes in the wheelchair frame.
2. Install rear storage compartment onto chair frame.
3. Turn two (2) 1/4-turn bolts that secure the rear storage compartment to the wheelchair frame CLOCKWISE.
4. Position rear shroud on the two (2) side shrouds and slide towards the front of the wheelchair until it stops.
5. Press down on the rear shroud until the two (2) clips secure the rear shroud to the two (2) side shrouds.

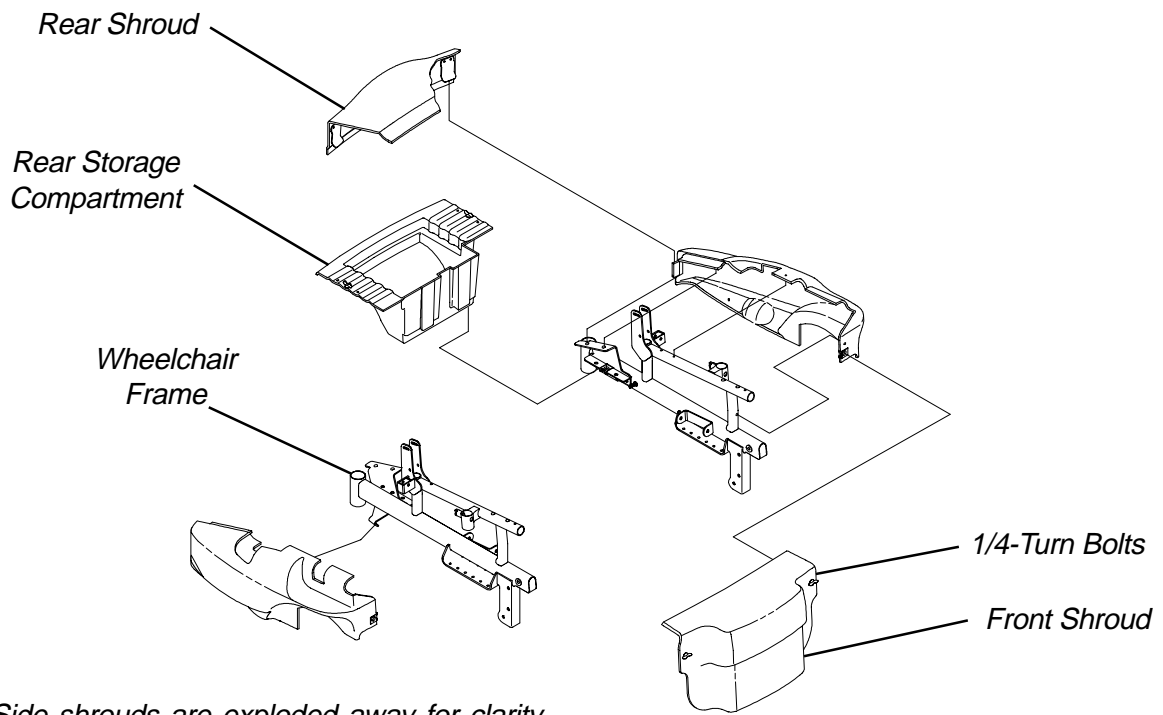

*NOTE: Side shrouds are exploded away for clarity. There is no need to remove side shrouds.*

**FIGURE 1 - REMOVING/INSTALLING SHROUDS - MWD WHEELCHAIRS**

**S  
H  
R  
O  
U  
D  
S**

**FWD Wheelchairs (FIGURE 2)****REMOVING FRONT SHROUD.**

1. Unclip the retaining strap securing the front shroud and battery box to the wheelchair.
2. Feed the retaining strap through the front shroud.
3. Remove the front shroud from the wheelchair.

**INSTALLING FRONT SHROUD.**

1. Feed the retaining strap through the front shroud as shown in FIGURE 2.
2. Position the bottom of the front shroud between the battery box and the battery tray.
3. Clip the retaining strap together.
4. Pull end of retaining strap to secure front battery box and front shroud in place.

**REMOVING REAR SHROUD.**

1. Perform one (1) of the following:
  - A. For 16,18, and 20-inch wide chairs:
    - Unclip the retaining strap securing the rear shroud and battery box to the wheelchair.
    - Feed the retaining strap through the rear shroud.
    - Remove the rear shroud from the wheelchair.
  - B. For 14-inch wide chairs:
    - Lift up on rear shroud and remove from wheelchair.

**INSTALLING REAR SHROUD.**

1. Perform one (1) of the following:
  - A. For 16,18, and 20-inch wide chairs:
    - Feed the retaining strap through the front shroud as shown in FIGURE 2.
    - Clip the retaining strap together.
    - Press down on the rear shroud until the two (2) clips secure the rear shroud to the two (2) side shrouds.
    - Pull end of retaining strap to secure rear battery box and front shroud in place.
  - B. For 14-inch wide chairs:
    - Align clips of rear shroud with tabs on side shrouds.
    - Press down on rear shroud until the two clips and dual lock fastener secure the rear shroud in place.



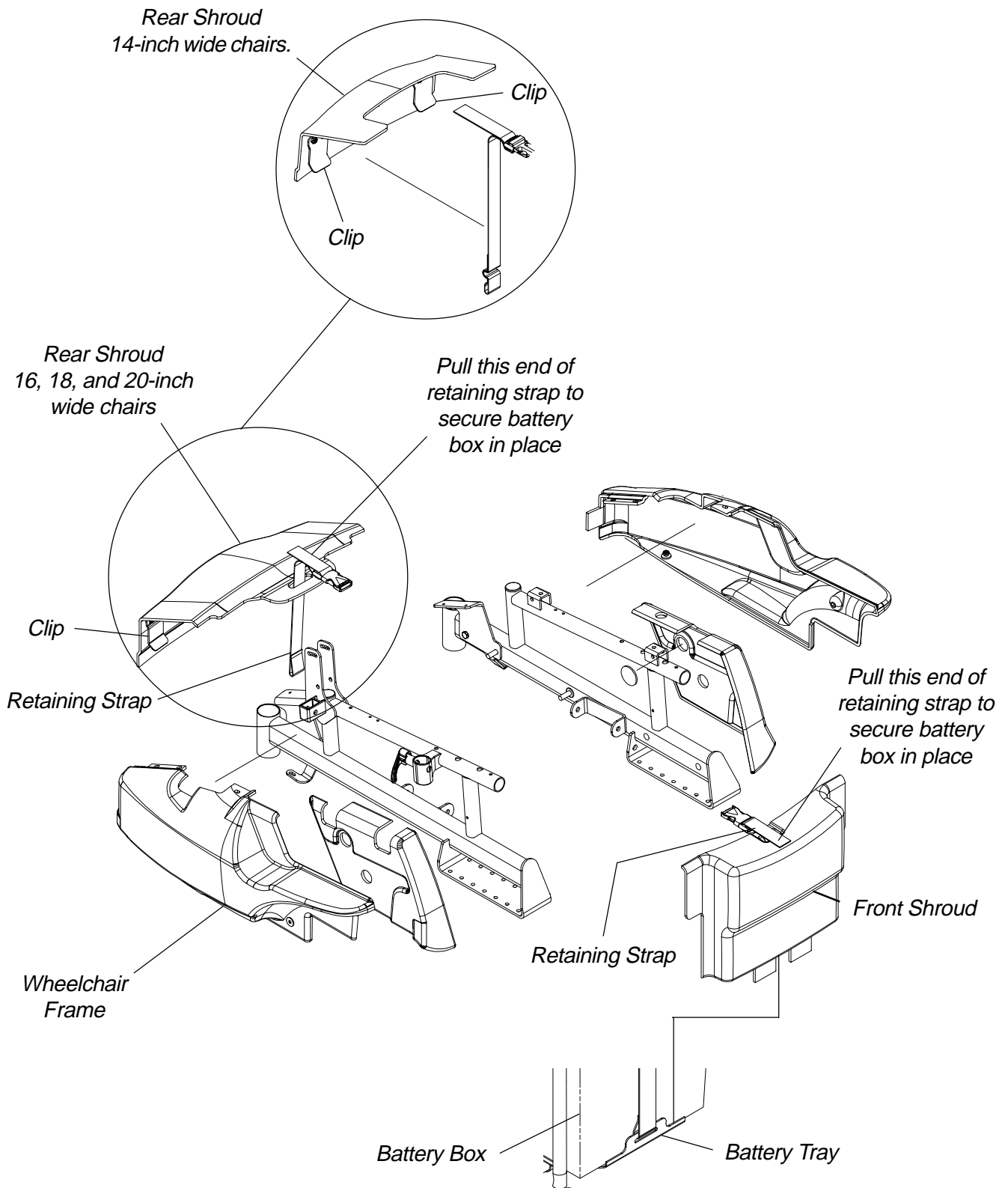

FIGURE 2 - REMOVING/INSTALLING SHROUDS - FWD WHEELCHAIRS

**This Procedure includes the following:**

**Installing/Removing Batteries into/From Battery Boxes**

**Connecting Battery Cables**

**WARNING**

Make sure power to the wheelchair is OFF before performing this procedure.

The use of rubber gloves and safety glasses is recommended when working with batteries.

Invacare strongly recommends that battery installation and battery replacement ALWAYS be done by a qualified technician.

After ANY adjustments, repair or service and BEFORE use, make sure all attaching hardware is tightened securely - otherwise injury or damage may result.

NOTE: For additional battery information, refer to PROCEDURE 11 - FWD wheelchairs or PROCEDURE 12 - MWD wheelchairs.

**INSTALLING/REMOVING BATTERIES INTO/FROM BATTERY BOXES (FIGURE 1)**

NOTE: To remove the battery(ies) from the battery box(es), reverse the following procedure.

NOTE: Have the following tools available:

TOOL	QTY	COMMENTS
Battery Lifting Strap	1	See Note
1/2-inch (6 pt) Box Wrench	1	Not Supplied
7/16-inch (6pt) Box Wrench	1	Not Supplied
3/8-inch (6pt) Box Wrench	1	Not Supplied
Diagonal Cutters	1	Not Supplied

\*NOTE: The Battery Lifting strap supplied is for Group 22 NF Batteries ONLY. Refer to the battery manufacturer for the proper lifting strap and/or battery tools for U1 battery removal/installation.

**WARNING**

ALWAYS use a battery lifting strap when lifting a battery. It is the most convenient method and assures that the battery acid will not spill. It also helps to prolong the life of the battery.

DO NOT tip the batteries. Keep the batteries in an upright position.

NOTE: If there is battery acid in the bottom or on the sides of the battery box(es) or battery(ies), apply baking soda to these areas to neutralize the battery acid. Before reinstalling the NEW or existing battery(ies), clean the baking soda from the battery box(es) or battery(ies).

NOTE: When securing battery lifting strap to battery, observe polarity markings located on the ends of the battery lifting strap, (+) side to POSITIVE (+) battery terminal/post and (-) side to NEGATIVE (-) battery terminal/post.

1. If necessary, remove the battery boxes from the wheelchair. Refer to INSTALLING/REMOVING BATTERY BOXES in PROCEDURE 11 - FWD or PROCEDURE 12 - MWD of this manual.
2. Secure the battery lifting strap to battery terminal(s)/post(s) (FIGURE 1).

**CAUTION**

Some battery manufacturers mold a carrying strap and/or hold down flanges directly into the battery case. Batteries which interfere with the battery box cannot be used for these applications. Attempting to "wedge" a battery into a battery box may damage the box and/or the battery.

3. Place batteries into battery box bottom.

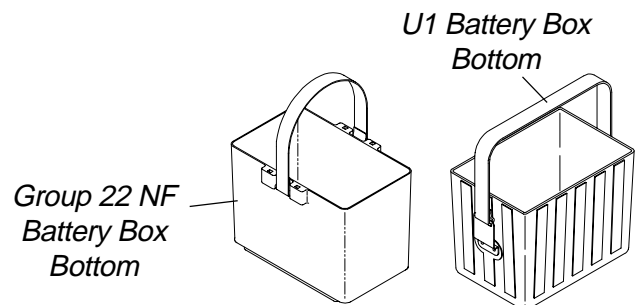
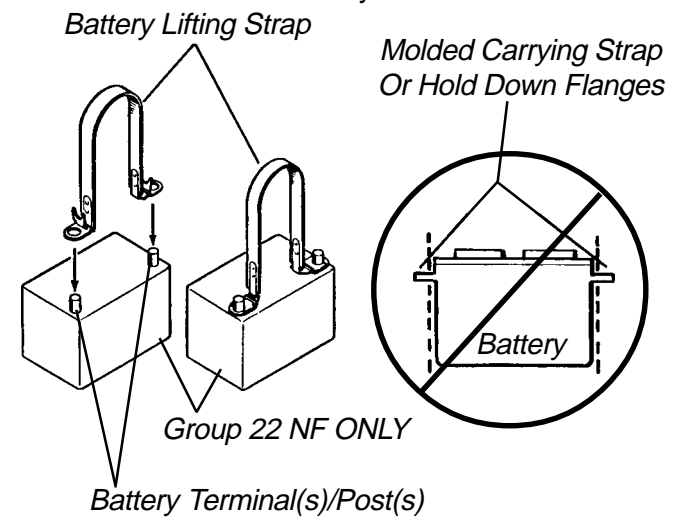

FIGURE 1 - INSTALLING/REMOVING BATTERIES INTO/FROM BATTERY BOXES

**CONNECTING BATTERY CABLES**

**WARNING**

NEVER allow any of your tools and/or battery cable(s) to contact BOTH battery terminal(s)/post(s) at the same time. An electrical short may occur and serious personal injury or damage may occur.

The use of rubber gloves and safety glasses is recommended when working with batteries.

**Dual U1 or Dual Group 22 NF Battery Boxes**

Perform one (1) of the following methods for connecting the battery cable(s):

- A. **FOR DUAL U1 BATTERIES** - Use direct mount method. Refer to FIGURES 2, 3 AND 4.
- B. **FOR DUAL GROUP 22 NF BATTERIES THAT HAVE MOUNTING HOLES IN THE BATTERY TERMINAL(S)/POST(S)** - Use direct mount method. Refer to FIGURES 2 AND 3.
- C. **FOR DUAL GROUP 22 NF BATTERIES THAT DO NOT HAVE MOUNTING HOLES IN THE BATTERY TERMINAL(S)/POST(S)** - Use battery clamp method. Refer to FIGURES 5, 6 AND 7.

**DIRECT MOUNT METHOD (FIGURE 2, 3 AND 4).**

1. Install battery terminal cap(s) onto battery cable(s) as follows (FIGURE 2):

**DUAL U1 BATTERIES:**

- A. ORANGE battery terminal cap onto RED battery cable.
- B. GRAY battery terminal cap onto BLACK battery cable.

**DUAL GROUP 22 NF BATTERIES:**

- A. RED battery terminal cap onto RED battery cable.
- B. BLACK battery terminal cap onto BLACK battery cable.

**INSTALLING BATTERY TERMINAL CAPS**

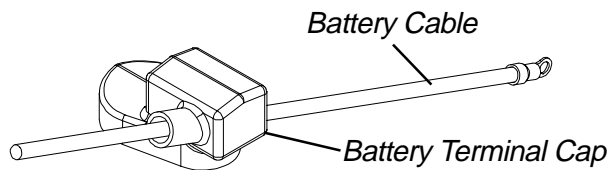

*NOTE: Only one (1) battery cable and terminal cap shown for clarity. Both caps install in the same manner.*

**FIGURE 2 - CONNECTING BATTERY CABLES - DIRECT MOUNT METHOD**

**CAUTION**

When connecting the battery cables to the battery(ies), the battery cable(s) MUST be connected to the battery terminal(s)/post(s) as shown in DETAIL "A" or DETAIL "B" of FIGURE 3 (depending on battery type), otherwise damage to the battery cable may result when installing battery terminal caps.

2. Connect battery cable(s) to battery(ies) terminal(s)/post(s) as follows (DETAIL "A" or DETAIL "B" of FIGURE 3, depending on battery type):
  - A. NEGATIVE (-) BLACK battery cable to NEGATIVE (-) battery terminal/post.
  - B. POSITIVE (+) RED battery cable to POSITIVE (+) battery terminal/post.
3. Secure the battery cable(s)/ring terminal(s) to the battery terminal(s)/post(s), BLACK to NEGATIVE (-) and RED to POSITIVE (+), with the provided 1/4-20 x 7/8-inch hex flange screw and hex flange locknut. Securely tighten. (DETAIL "A" or DETAIL "B" of FIGURE 3, depending on battery type).
4. Verify all battery cable(s)/ring terminal(s) are correctly installed and securely tightened.
5. Slide terminal cap(s) down battery cable(s) and onto battery clamps (FIGURE 3).
6. Secure each terminal cap in place with a tie-wrap (Use tie-wraps 11-1/2-inches long) (FIGURE 3).
 

*NOTE: It will be necessary to trim excess tie-wrap in order to install the battery box top(s).*
7. Install the battery box top(s).
8. Install the battery box(es) into the wheelchair. Refer to **INSTALLING/REMOVING BATTERY BOX(ES)** in the PROCEDURE 11 - FWD MODELS or PROCEDURE 12 - MWD MODELS of this manual.
 

*NOTE: New Battery(ies) MUST be fully charged BEFORE using, otherwise the life of the battery(ies) will be reduced.*
9. If necessary, charge the battery(ies). Refer to **CHARGING BATTERIES** in the PROCEDURE 11 - FWD MODELS or PROCEDURE 12 - MWD MODELS of this manual.

BATTERIES

**DETAIL "A"**  
**DUAL U1 BATTERIES**

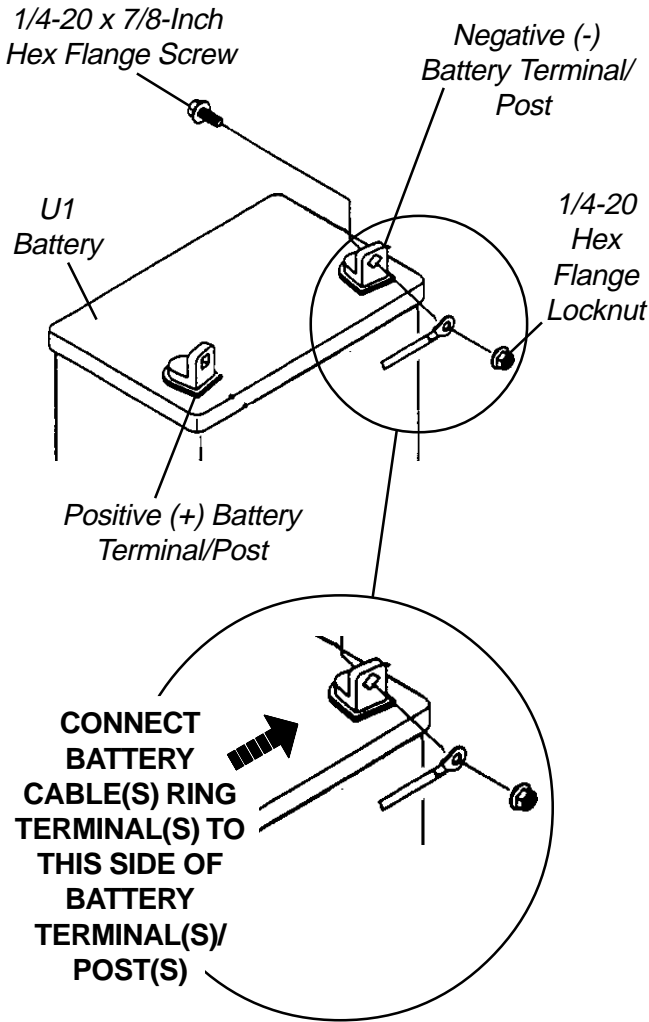

**DETAIL "B"**  
**DUAL GROUP 22 NF BATTERIES**

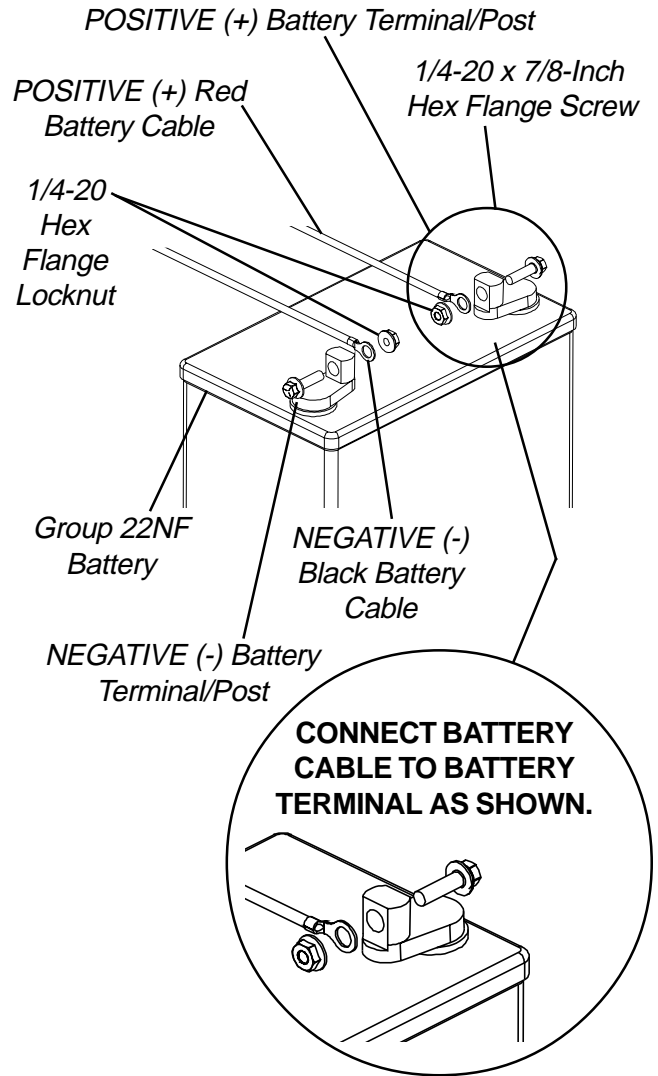

**DUAL U1 BATTERIES**

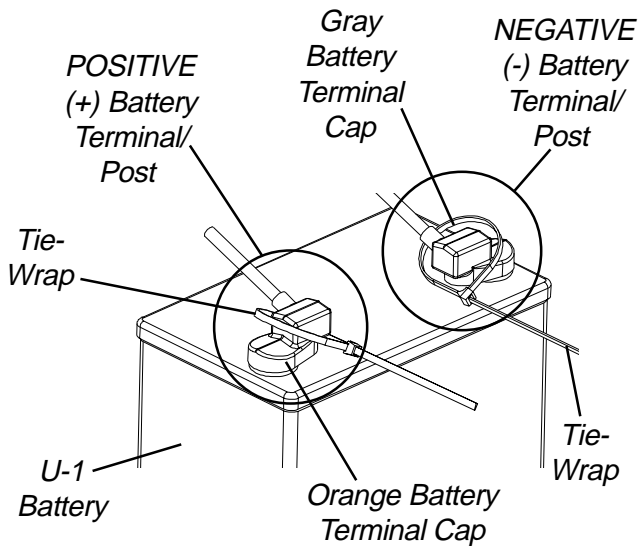

**DUAL GROUP 22 NF BATTERIES**

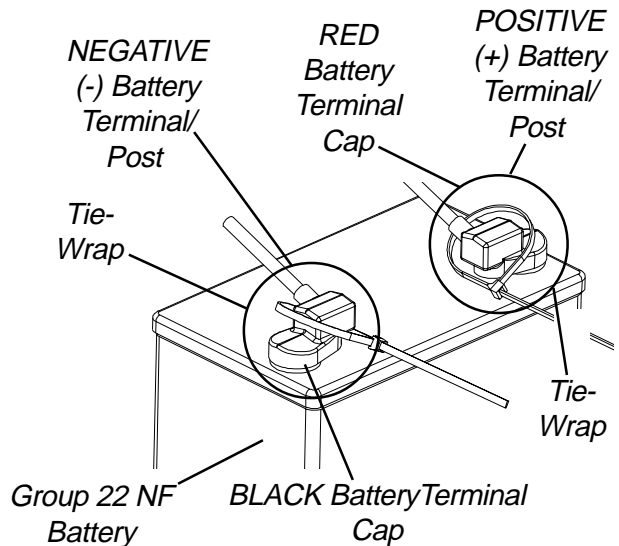

**FIGURE 3 - CONNECTING BATTERY CABLES - DIRECT MOUNT METHOD**

**BATTERY CLAMP METHOD (FIGURES 4, 5 AND 6).**

**CAUTION**

The battery clamp of the POSITIVE (+) battery terminal/post MUST be mounted in the position shown in FIGURE 5, otherwise the battery box top cannot be installed properly.

1. Perform one (1) of the following:
  - A. If the battery clamp of the POSITIVE (+) battery terminal/post is **NOT** mounted in the orientation shown in FIGURE 5, perform the following:
    - Loosen the hex nut that secures the battery clamp to the POSITIVE (+) battery terminal/post.
  - B. If the battery clamp on the POSITIVE (+) battery terminal/post is positioned as shown in FIGURE 4, proceed to STEP 2.

**CORRECT ORIENTATION OF THE POSITIVE (+) BATTERY TERMINAL/POST BATTERY CLAMP**

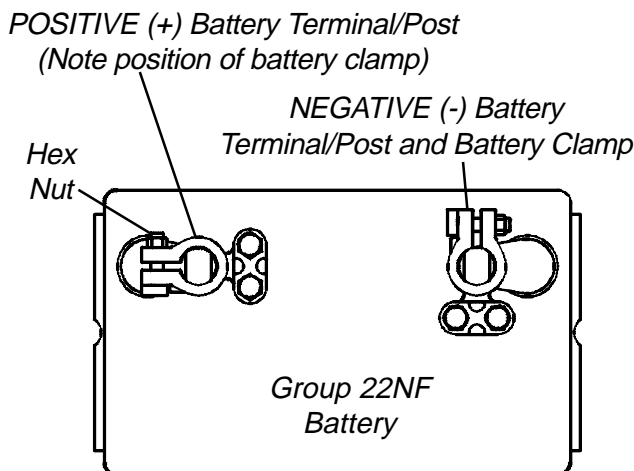
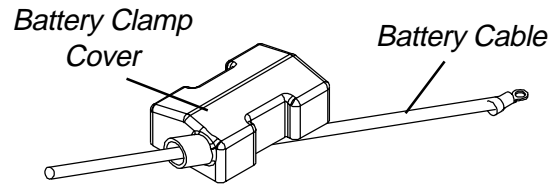

**FIGURE 4 - CONNECTING BATTERY CABLES - BATTERY CLAMP METHOD**

2. Install battery clamp covers onto battery cables as follows: (FIGURE 5)
  - A. RED battery clamp cover onto RED battery cable.
  - B. BLACK battery clamp cover onto BLACK battery cable.

*NOTE: Only one (1) battery cable and battery clamp cover are shown for clarity. Both battery clamp covers install in the same manner.*

**INSTALLING BATTERY CLAMP COVERS**



**FIGURE 5 - CONNECTING BATTERY CABLES - BATTERY CLAMP METHOD**

**CAUTION**

When connecting the battery cable/ring terminal(s) to the battery(ies) clamp(s), the battery cable(s) MUST be connected in the position shown in DETAIL "A", otherwise damage may occur to the battery cable and/or battery clamp covers.

3. Connect battery cable(s) to battery(ies) terminal(s)/post(s) as follows (DETAIL "A"):
    - A. NEGATIVE (-) BLACK battery cable/ring terminal between the mounting plate and battery clamp of NEGATIVE (-) battery terminal/post.
    - B. POSITIVE (+) RED battery cable/ring terminal between the mounting plate and battery clamp of POSITIVE (+) battery terminal/post.
  4. Secure the battery cable(s)/ring terminal(s) to the battery clamp(s), BLACK to NEGATIVE (-) and RED to POSITIVE (+), with existing hex screws. Securely Tighten. (DETAIL "A")
  5. Verify battery cable ring terminal(s) are correctly installed and securely tightened.
  6. Slide battery clamp covers down battery cables and onto battery terminals. (DETAIL "B")
  7. Secure each terminal cap in place with a tie-wrap (Use tie-wraps 11-1/2-inches long). (DETAIL "B")
- NOTE: It will be necessary to trim excess tie-wrap in order to install the battery box top(s).*
8. Install the battery box top(s).

BATTERIES

9. Install the battery box(es) into the wheelchair. Refer to INSTALLING/REMOVING BATTERY BOX(ES) in the PROCEDURE 11 - FWD MODELS or PROCEDURE 12 - MWD MODELS of this manual.

10. If necessary, charge the battery(ies). Refer to CHARGING BATTERIES in the PROCEDURE 11 - FWD MODELS or PROCEDURE 12 - MWD MODELS of this manual.

**NOTE: New Battery(ies) MUST be fully charged BEFORE using, otherwise the life of the battery(ies) will be reduced.**

**CONNECTING BATTERY CABLE(S) TO BATTERY(IES) TERMINAL(S)/POST(S)**

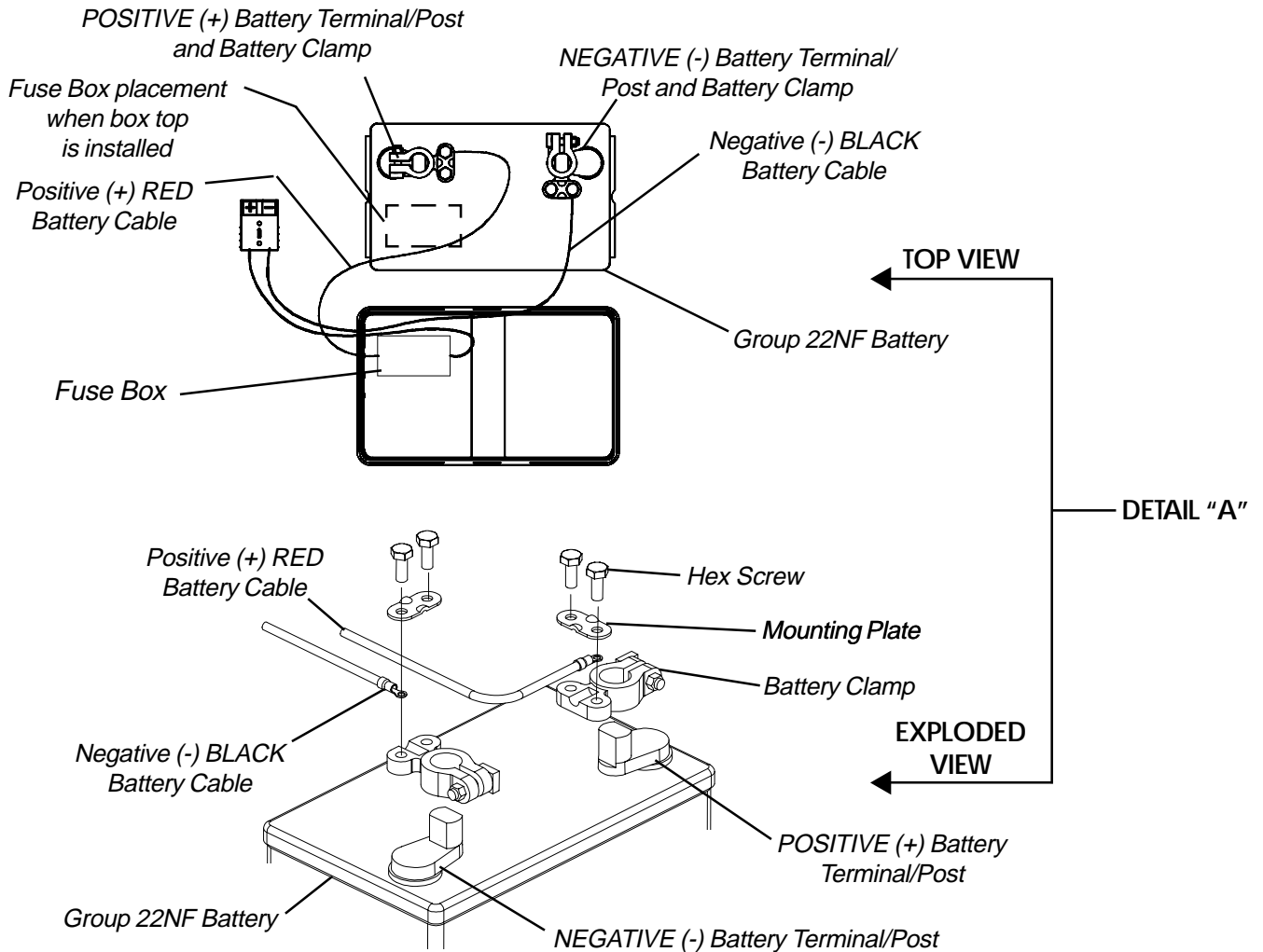

**NOTE: Battery clamps exploded away for clarification purposes only.**

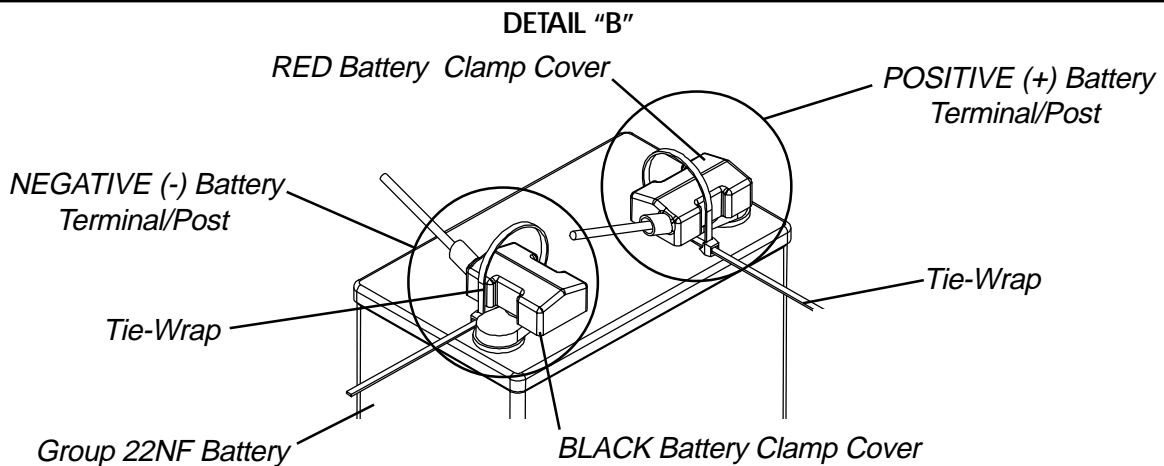

**FIGURE 6 - CONNECTING BATTERY CABLES - BATTERY CLAMP METHOD**

***This Procedure Includes the Following:***  
***Transporting Ranger II FWD***  
***When to Charge Batteries***  
***Charging Batteries***  
***Replacing Batteries***  
***Installing/Removing Battery Boxes***  
***Battery Tray***

**WARNING**  
 After ANY adjustments, repair or service and BEFORE use, make sure all attaching hardware is tightened securely - otherwise injury or damage may result.

**TRANSPORTING RANGER II FWD**

**WARNING**  
 The weight of the wheelchair without the user and batteries is still between 83 and 115 lbs for integrated sling seats and 122 and 142 lbs for Captain's Seats. Use proper lifting techniques (lift with your legs) to avoid injury. Extreme caution is advised when it is necessary to move an UNOCCUPIED power wheelchair. Invacare recommends using two (2) assistants and making thorough preparations. Make sure to use ONLY secure, non-detachable parts for hand-hold supports.  
 Keep hands and fingers clear of moving parts to avoid injury.

**Unfolding/Folding - Integrated Sling Seats (FIGURE 1)**

**UNFOLDING.**

1. Push down on the seat rails until the seat rails are positioned in the seat guides.
2. Assemble the wheelchair. Refer to FIGURE 1.
3. If necessary, install the shrouds. Refer to REMOVING/INSTALLING SHROUDS in PROCEDURE 9 of this manual.

**FOLDING.**

1. If necessary, remove the shrouds. Refer to REMOVING/INSTALLING SHROUDS in PROCEDURE 9 of this manual.
2. Remove the batteries and footrests/legrests/footboard plate from the wheelchair. Refer to FIGURE 1.
3. Lift the battery tray UP and out of the way. Refer to BATTERY TRAY in this procedure of the manual.
4. Lift up on the seat rails of the wheelchair.

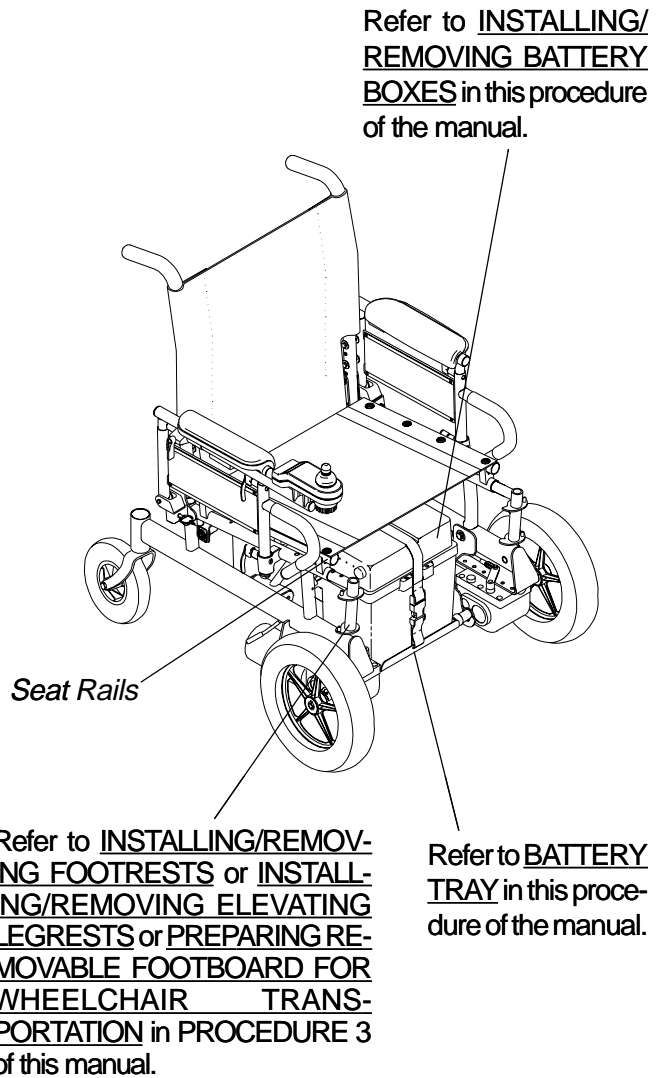

**FIGURE 1 - TRANSPORTING RANGER II FWD - INTEGRATED SLING SEATS**

**Unfolding/Folding - Captain's Seat (FIGURE 2)**

**UNFOLDING.**

1. Push down on the push brackets until they are flush with the pivot links on the crossbraces.
2. Assemble the wheelchair. Refer to FIGURE 2.
3. Install the shrouds. Refer to REMOVING/INSTALLING SHROUDS in PROCEDURE 9 of this manual.
4. Install the Captain's Seat. Refer to REMOVING/INSTALLING CAPTAIN'S SEAT in PROCEDURE 5 of this manual.
5. **HIGH BACK CAPTAIN'S SEATS ONLY** - Connect the limit switch. Refer to DISCONNECTING/CONNECTING LIMIT SWITCH in PROCEDURE 6 of this manual.

**FOLDING.**

1. **HIGH BACK CAPTAIN'S SEATS ONLY** - Disconnect the limit switch. Refer to DISCONNECTING/CONNECTING LIMIT SWITCH in PROCEDURE 6 of this manual.

2. Remove the Captain's Seat. Refer to REMOVING/INSTALLING CAPTAIN'S SEAT in PROCEDURE 5 of this manual.
3. Remove the shrouds. Refer to REMOVING/INSTALLING SHROUDS in PROCEDURE 9 of this manual.

Refer to INSTALLING/REMOVING FOOTRESTS or INSTALLING/REMOVING ELEVATING LEGRESTS or PREPARING REMOVABLE FOOTBOARD FOR WHEELCHAIR TRANSPORTATION in PROCEDURE 3 of this manual.

Refer to INSTALLING/REMOVING BATTERY BOXES in this procedure of the manual.

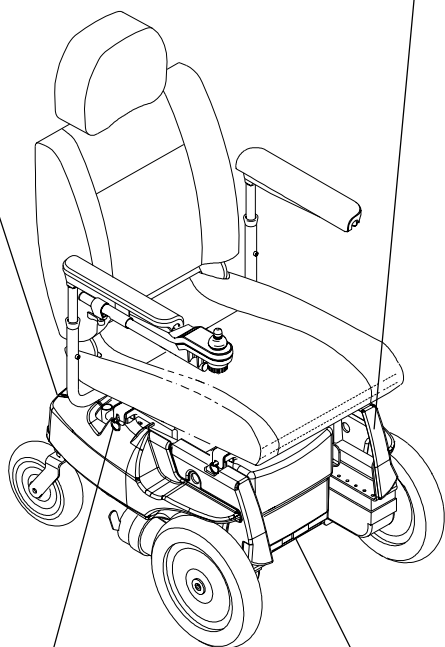

**CAUTION**  
**HIGHBACK CAPTAIN'S SEATS ONLY** - Disconnect limit switch **BEFORE** removing seat - damage to seat can occur.

Disconnect the limit switch. Refer to DISCONNECTING/CONNECTING LIMIT SWITCH in PROCEDURE 6 of this manual.

Lift battery tray UP and out of the way. Refer to BATTERY TRAY in this procedure of the manual.

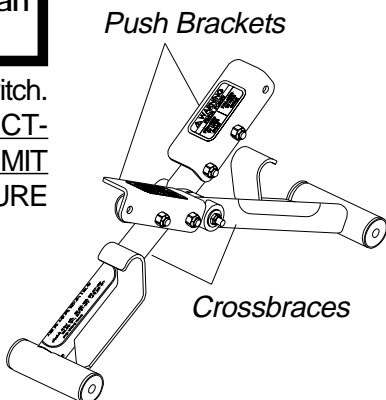

FIGURE 2 - TRANSPORTING RANGER II FWD - CAPTAIN'S SEATS

4. Remove the batteries and footrests/legrests/footboard plate from the wheelchair. Refer to FIGURE 2.
5. Lift the battery tray UP and out of the way. Refer to **BATTERY TRAY** in this procedure of the manual.
6. Lift up on push brackets located on the crossbraces.

**WHEN TO CHARGE BATTERIES (FIGURE 3)**

It is advantageous to recharge frequently rather than only when necessary. In fact, a battery's life is extended if the charge level is maintained well above a low condition.

**MKIV RII Joystick**

**BATTERY DISCHARGE INDICATOR (BDI)** is located at the rear of the joystick housing and provides information on the remaining charge in the batteries. At FULL charge the BDI will be GREEN. As the battery becomes discharged, the BDI indicator will turn AMBER (YELLOW), then RED and finally FLASHING RED. If the BDI is FLASHING RED, the user should charge the batteries as soon as possible.

*NOTE: Accurate readings are displayed when in neutral.*

**MCC-MKIV X, A or A+ Joystick**

**BATTERY GAUGE DISPLAY (BGD)** is the bar graph display located on the MKIV X, A or A+ joystick. It will keep you informed as to power availability. A visual warning is given before the power becomes too low to operate the wheelchair. At full charge the two (2) LEFT segments and the farthest RIGHT segment of the bar graph will be illuminated. As the battery becomes discharged, the farthest RIGHT segment will progressively move to the LEFT until only the last two (2) bars (LEFT) are illuminated. At this level the last two (2) bars (LEFT) will start to Flash ON and OFF to indicate that the end user should charge the batteries as soon as possible.

*NOTE: Accurate readings are displayed when in neutral.*

Battery Discharge Indicator (BDI)

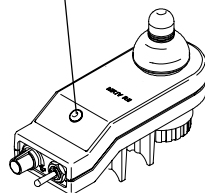

MKIV- RII JOYSTICK

Battery Gauge Display (BGD)

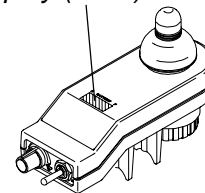

MKIV X, A OR A+ JOYSTICK

*NOTE: MKIV X Shown.*

FIGURE 3- WHEN TO CHARGE BATTERIES



## CHARGING BATTERIES (FIGURE 4)

### WARNING

Never attempt to recharge the batteries by attaching cables directly to the battery terminals or clamps. Always use the recharging plug located on the side of the wheelchair frame.

DO NOT attempt to recharge the batteries and operate the power wheelchair at the same time.

During use and charging, unsealed batteries will vent hydrogen gas which is explosive in the right concentration with air.

### CAUTION

Always charge new batteries fully BEFORE initial use or battery life will be reduced.

*NOTE: As a general rule, batteries should be recharged daily to assure the longest possible life and minimize the required charging time. Plan to recharge the batteries when it is anticipated the wheelchair will not be used for several days.*

The range per battery charge using recommended batteries should be approximately 5 to 9 hours of typical operation. Extensive use on inclines or age of batteries may substantially reduce per charge mileage.

### Description and Use of Battery Chargers

The charger automatically reduces the amount of charge from an initially high rate to a zero reading at a fully charged condition.

### SHUTOFF PROCEDURE.

- A. **For Models RANGER II<sub>BASIC</sub> and RANGER II<sub>STANDARD</sub>** -If left unattended, the charger will automatically shut-off when full charge is obtained.
- B. **For RANGER II<sub>250 SERIES</sub>** -The Charger output and green light will stay ON until the power switch on the battery charger is moved to the OFF position.

**There are some basic concepts which will help you understand this automatic process:**

The amount of electrical current drawn within a given time to charge a battery is called "charge rate". If, due to usage, the charge stored in the battery is low, the charge rate is high. (**FOR MODELS RANGER II<sub>BASIC</sub> and RANGER II<sub>STANDARD</sub>** - this is indicated by the green light on the charger. Initially, the green light will stay illuminated for a short period of time followed by a longer period of off time.)

As a charge builds up, the charge rate is reduced, and the following will occur:

- A. **For Models RANGER II<sub>BASIC</sub> and RANGER II<sub>STANDARD</sub>** - the green light will stay illuminated for a longer period of time followed by a shorter off time.

- B. **For Model RANGER II<sub>250 SERIES</sub>** - the battery charger rate decreases to a "trickle charge".

*NOTE: If performing the charging procedures independently, READ and CAREFULLY follow the individual instructions for each charger (supplied or purchased).*

*NOTE: If charging instructions are not supplied, consult a qualified service technician for proper procedures.*

### Required Items:

TOOL	QUANTITY	COMMENTS
Battery Charger	1	Supplied
✪ Extension Cord	1	Not Supplied

✪ 3-prong plug, 15 ampere current rating; industrial type

1. Attach the battery charger connector to the charger cable/battery harness.
2. Plug the charger's AC power cord, or extension, into the grounded 120 VAC wall outlet.
3. Wait until charging is complete.

*NOTE: Allow eight (8) hours for normal charging. Larger batteries (greater than 55 ampere-hours) or severely discharged batteries may require up to sixteen (16) hours to be properly charged and equalized.*

*NOTE: RANGER II<sub>BASIC</sub> and RANGER II<sub>STANDARD</sub> ONLY* - If the charger operates for sixteen (16) hours and is unable to fully charge the batteries, an internal timer turns the charger off and begins to fast blink the green light.

*NOTE: If the batteries need to be charged more often or take longer to charge than normal, they may need to be replaced. Contact a qualified technician for service.*

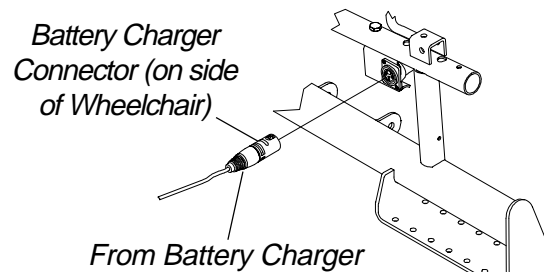

*NOTE: Position of Battery Charger Connector may vary depending on wheelchair options.*

FIGURE 4- CHARGING BATTERIES

## REPLACING BATTERIES

### WARNING

Most batteries are not sold with instructions. However, warnings are frequently noted on the cell caps. Read them carefully, otherwise injury or damage can occur.

*NOTE: Invacare recommends that both batteries be replaced if one (1) battery is defective.*

**Recommended Battery Types**

**WARNING**

The warranty and performance specifications contained in this manual are based on the use of deep cycle gel cell or sealed lead acid batteries. Invacare strongly recommends their use as the power source for this unit.

**CAUTION**

Failure to use the correct battery size and/or voltage may cause damage to the wheelchair and give unsatisfactory performance.

CHAIR SEAT WIDTH	QTY	VOLTS	BATTERY SIZE*	REMARKS
14-inch	2	12	U1	Deep Cycle
16,18, 20-inches	2	12	22NF	Deep Cycle

\*NOTE: RANGER II<sub>250 SERIES</sub> requires U1 gel cell batteries.  
 NOTE: Charge batteries daily. It is critical not to let them run low at any time.

1. Remove the battery boxes from the wheelchair. Refer to REMOVING/INSTALLING BATTERY BOXES in this procedure of the manual.
2. Remove the existing batteries from the battery boxes. Refer to INSTALLING/REMOVING BATTERIES INTO/FROM BATTERY BOXES in PROCEDURE 10 of this manual.
3. Clean the new battery terminals.
4. Install the new batteries into the battery boxes. Refer to INSTALLING/REMOVING BATTERIES TO/FROM BATTERY BOXES in PROCEDURE 10 of this manual.

**Cleaning Battery Terminals**

**WARNING**

DO NOT allow the liquid in the battery to come in contact with skin, clothes or other possessions. It is a form of acid and harmful or damaging burns may result. Should the liquid touch your skin, wash the area immediately and thoroughly with cool water. In serious cases or if eye contact is made, seek medical attention IMMEDIATELY.

NEVER smoke or strike a match near batteries. If the caps of the battery cells are removed, NEVER look directly into them while charging batteries.

1. Examine battery clamps and terminals for corrosion.
2. Verify that the plastic caps are in place over the battery cell holes.

3. Clean the terminals and inside the battery clamps by using a battery cleaning tool, wire brush, or medium grade sand paper.  
 NOTE: When done, these areas should be shiny, not dull.
4. Carefully dust off all metal particles.

**INSTALLING/REMOVING BATTERY BOXES**

**WARNING**

NEVER unplug the battery cables by pulling on the wires. Unplug the battery cables by pulling on the connector ONLY. Otherwise, injury or damage may occur.

NOTE: To remove the battery boxes, reverse the following procedure.

NOTE: If the wheelchair is equipped with the removeable footboard AND it is installed in the highest position, it is necessary to remove the footboard plate BEFORE removing the battery boxes. Refer to PREPARING THE REMOVEABLE FOOTBOARD FOR WHEELCHAIR TRANSPORTATION in PROCEDURE 3 of this manual.

NOTE: Motors should be in the engaged position when removing/installing batteries. Refer to ENGAGING/DISENGAGING MOTORS in PROCEDURE 8 of this manual.

**Installing**

**RANGER II<sub>BASIC</sub> , RANGER II<sub>STANDARD</sub> AND RANGER II<sub>250 SERIES</sub> (FIGURE 5).**

1. Verify that the ON/OFF switch on the joystick is in the OFF position.
2. If necessary, remove the captain's seat. Refer to REMOVING/INSTALLING THE CAPTAIN'S SEAT in PROCEDURE 5 of this manual.
3. If necessary, remove the front and rear shrouds. Refer to REMOVING/INSTALLING THE SHROUDS in PROCEDURE 9 of this manual.
4. Position the battery boxes onto the battery tray.

NOTE: Make sure the battery cable on the battery boxes are on the same side as the battery connectors on the wheelchair frame.

5. Position the bottom of the front shroud in-between the battery box and the battery tray.
6. Feed the retaining strap through the slot located on the top of the front shroud.
7. Clip the retaining strap together to secure the front shroud and battery box in place.

8. Feed the retaining strap through the slot located on the top of the rear shroud.
9. Bundle excess joystick cable and tie wrap together. See **DETAIL "A"**.
10. Position bundled joystick cable between retaining strap and rear battery box. See **DETAIL "A"**.
11. Clip the retaining strap together to secure the rear shroud and battery box in place.
12. Press down on the rear shroud until the two (2) clips secure the rear shroud to the two side shrouds.
13. Connect the battery leads from the battery boxes to the battery connectors on the wheelchair frame.
14. If necessary, install the Captain's Seat. Refer to REMOVING/INSTALLING CAPTAIN'S SEAT in PROCEDURE 5 of this manual.
15. If necessary, reinstall the removeable footboard. Refer to PREPARING THE REMOVEABLE FOOTBOARD FOR WHEELCHAIR TRANSPORTATION in PROCEDURE 3 of this manual.

**RANGER II<sub>JR</sub> (FIGURE 6).**

1. Verify that the ON/OFF switch on the joystick is in the OFF position.
2. If necessary, remove the front and rear shrouds. Refer to REMOVING/INSTALLING SHROUDS in PROCEDURE 9 of this manual.

*NOTE: Make sure the battery cables on the battery boxes are on the same side as the battery connectors on the wheelchair frame.*

**WARNING**

**The battery connector on the front battery box MUST be connected to the wiring harness before placing front battery on battery tray. Otherwise, injury may result.**

3. Connect the battery cables from the front battery box to the battery connectors on the wheelchair frame.
4. Position the front battery box onto the battery tray as shown in FIGURE 6.
5. Feed the front retaining strap through the slot located on the top of the front shroud.
6. Position the bottom of the front shroud in-between the front battery box and edge of battery tray.
7. Clip the front retaining strap together.
8. Pull end of retaining strap to secure front battery box and front shroud in place.
9. Position the rear battery box onto the battery tray as shown in FIGURE 6.
10. Connect the battery cable from the rear battery box to the rear battery connectors on the wheelchair frame.
11. Bundle excess joystick cable and tie wrap together. See **DETAIL "A"**.
12. Position excess joystick cable between retaining strap and rear battery box. See **DETAIL "A"**.
13. Clip the rear retaining strap together.
14. Pull end of retaining strap to secure battery box and joystick in place.
15. Install the rear shroud. Refer to REMOVING/INSTALLING SHROUDS in PROCEDURE 9 of this manual.
16. If necessary, reinstall the removeable footboard. Refer to PREPARING THE REMOVEABLE FOOTBOARD FOR WHEELCHAIR TRANSPORTATION in PROCEDURE 3 of this manual.

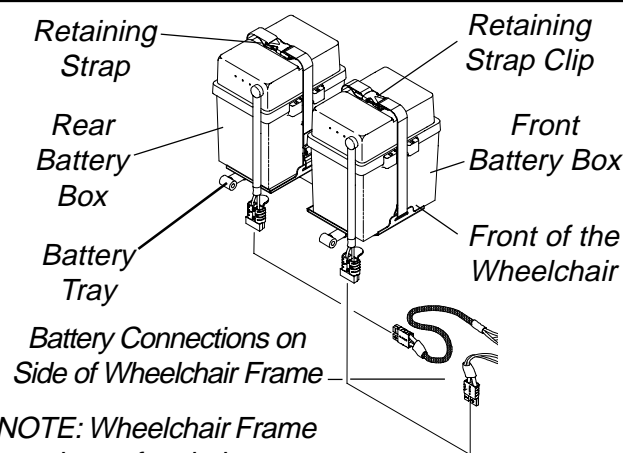
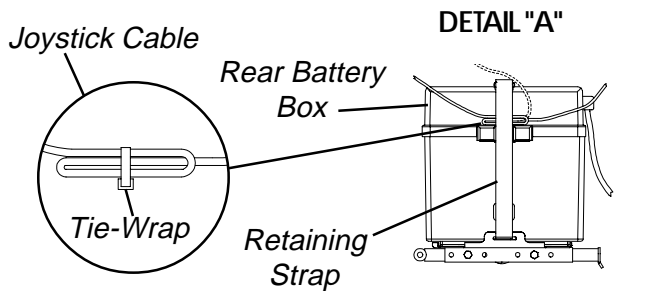

**FIGURE 5 - INSTALLING/REMOVING BATTERY BOXES ALL MODELS EXCEPT RANGER II<sub>JR</sub>**

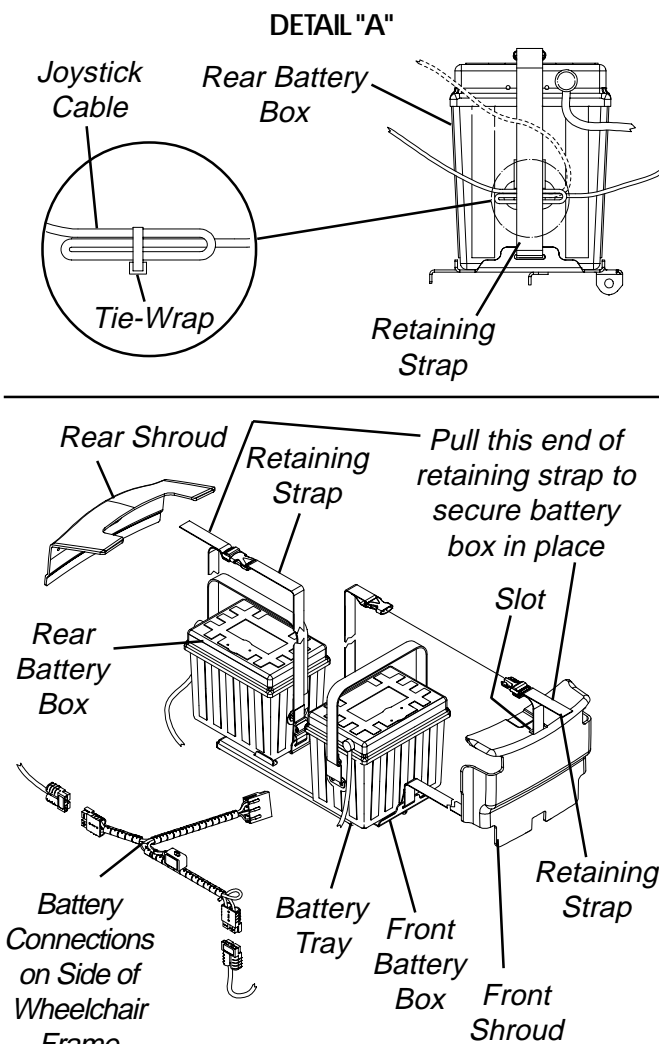

FIGURE 6 - INSTALLING/REMOVING BATTERY BOXES RANGER II<sub>JR</sub>

## BATTERY TRAY

**WARNING**  
Pinch point exists between battery tray and battery bracket.

### Folding Battery Tray for Transport (FIGURE 7)

1. If necessary, remove the front shroud. Refer to REMOVING/INSTALLING SHROUDS - FWD WHEELCHAIRS in PROCEDURE 9 of this manual.
2. Remove the battery boxes from the wheelchair. Refer to INSTALLING/REMOVING BATTERY BOXES in this procedure of the manual.
3. Perform one (1) of the following:
  - A. **FOR RANGER II<sub>BASIC</sub> and RANGER II<sub>STANDARD</sub>** - Lift up on the pin side of the battery tray and rotate UP towards the battery tray pivot.
  - B. **FOR RANGER II<sub>JR</sub>** - Lift up on the notched side of the battery tray and rotate UP towards the battery tray pivot.
4. Fold the wheelchair. Refer to TRANSPORTING RANGER II FWD in this procedure of the manual.

### Unfolding Battery Tray for Use (FIGURE 8)

1. Unfold the wheelchair. Refer to TRANSPORTING RANGER II FWD in this procedure of the manual.
2. Perform one (1) of the following:
  - A. **FOR RANGER II<sub>BASIC</sub> and RANGER II<sub>STANDARD</sub>**

**WARNING**  
Make sure pins of battery tray are secure in the mounting slots of the hanger bracket, otherwise injury or damage may result.

- A. Rotate the pin side of the battery tray DOWN against the mounting slots on the hanger bracket.
  - B. **FOR RANGER II<sub>JR</sub>** - Rotate the notched side of the battery tray and DOWN against the battery tray stop.
3. Install the battery boxes. Refer to INSTALLING/REMOVING BATTERY BOXES in this procedure of the manual.
4. If necessary install the front shroud. Refer to REMOVING/INSTALLING SHROUDS - FWD WHEELCHAIRS in PROCEDURE 9 of this manual.

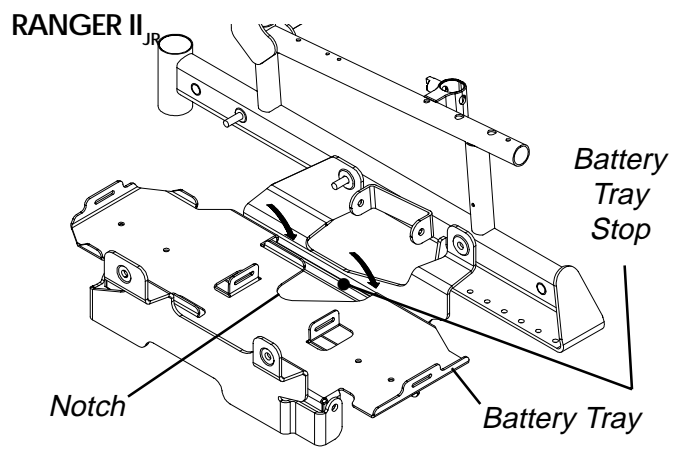
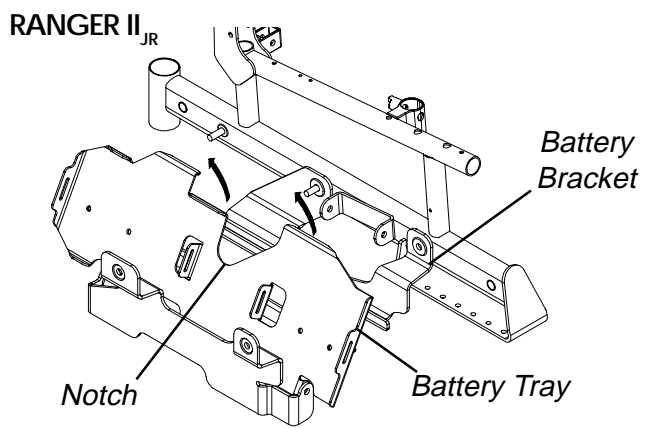
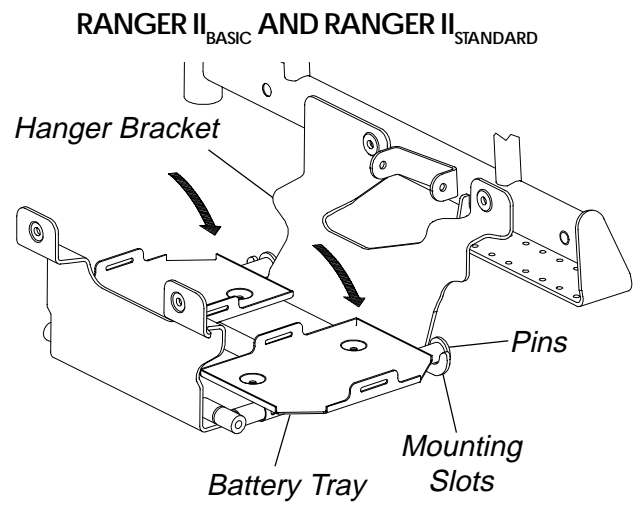
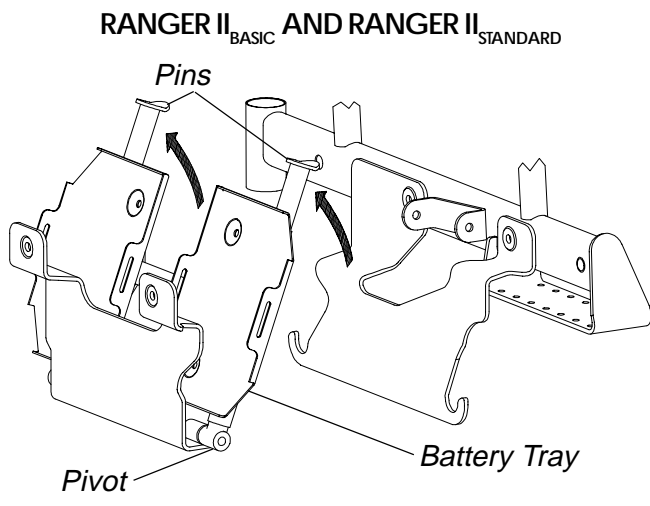

FIGURE 9 - BATTERY TRAY - FOLDING BATTERY TRAY FOR TRANSPORT

FIGURE 10 - BATTERY TRAY - UNFOLDING BATTERY TRAY FOR USE

***This Procedure Includes the Following:***

- Transporting Ranger II MWD***
- When to Charge Batteries***
- Charging Batteries***
- Replacing Batteries***
- Installing/Removing Battery Boxes***
- Battery Tray***

**WARNING**

After ANY adjustments, repair or service and BEFORE use, make sure all attaching hardware is tightened securely - otherwise injury or damage may result.

**TRANSPORTING RANGER II - MWD**

**WARNING**

The weight of the wheelchair without the user and batteries is still between 110 and 116 lbs for integrated sling seat models and 131 and 142lbs for Captain's Seat models. Use proper lifting techniques (lift with your legs) to avoid injury. Extreme caution is advised when it is necessary to move an UNOCCUPIED power wheelchair. Invacare recommends using two (2) assistants and making thorough preparations. Make sure to use ONLY secure, non-detachable parts for hand-hold supports.

Keep hands and fingers clear of moving parts to avoid injury.

**Unfolding/Folding - Integrated Sling Seats (FIGURE 1)**

**UNFOLDING.**

1. Push down on the seat rails until the seat rails are positioned in the seat guides.
2. Assemble the wheelchair. Refer to FIGURE 1.
3. If necessary, install the shrouds. Refer to REMOVING/INSTALLING SHROUDS in PROCEDURE 9 of this manual.

**FOLDING.**

1. If necessary, remove the shrouds. Refer to REMOVING/INSTALLING SHROUDS in PROCEDURE 9 of this manual.
2. Remove the batteries, battery tray and footrests/legrests/footboard plate from the wheelchair. Refer to FIGURE 1.
3. Lift up on the seat rails of the wheelchair.

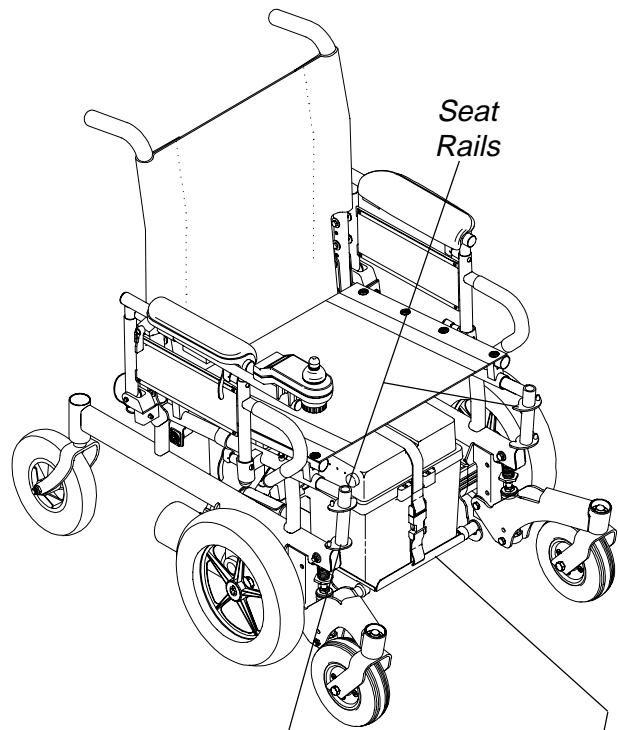

Refer to INSTALLING/REMOVING FOOTRESTS or INSTALLING/REMOVING ELEVATING LEGRESTS or PREPARING REMOVEABLE FOOTBOARD FOR WHEELCHAIR TRANSPORTATION in PROCEDURE 3 of this manual.

Refer to BATTERY TRAY and INSTALLING/REMOVING BATTERY BOXES in this procedure of the manual.

**FIGURE 1 - TRANSPORTING RANGER II MWD - INTEGRATED SLING SEATS**

**Unfolding/Folding - Captain's Seat (FIGURE 2)**

**UNFOLDING.**

1. Push down on the push brackets until they are flush with the pivot links on the crossbraces.
2. Assemble the wheelchair. Refer to FIGURE 2.
3. Install the shrouds. Refer to REMOVING/INSTALLING SHROUDS in PROCEDURE 9 of this manual.
4. Install the Captain's Seat. Refer to REMOVING/INSTALLING CAPTAIN'S SEAT in PROCEDURE 5 of this manual.
5. **HIGH BACK CAPTAIN'S SEATS ONLY** - Connect the limit switch. Refer to DISCONNECTING/CONNECTING LIMIT SWITCH in PROCEDURE 6 of this manual.

**FOLDING.**

1. **HIGH BACK CAPTAIN'S SEATS ONLY** - Disconnect the limit switch. Refer to DISCONNECTING/CONNECTING LIMIT SWITCH in PROCEDURE 6 of this manual.

Refer to BATTERY TRAYS - REMOVABLE BATTERY TRAYS and INSTALLING/REMOVING BATTERY BOXES in this procedure of the manual.

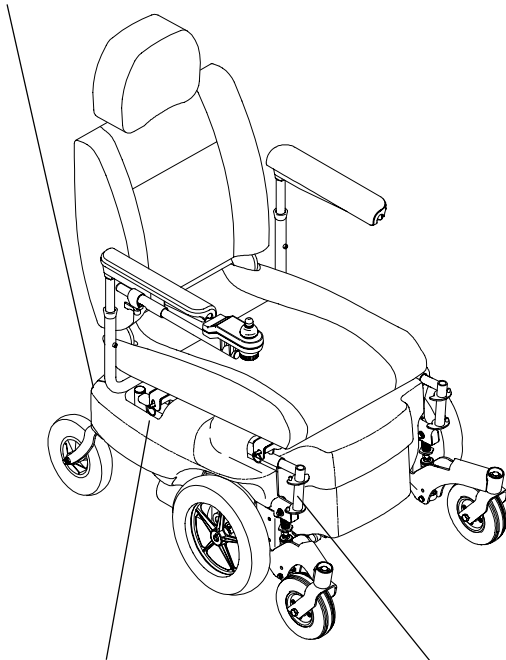

**CAUTION**  
**HIGH BACK CAPTAIN'S SEATS ONLY** - Disconnect limit switch **BEFORE** removing seat - damage to seat can occur.

Refer to DISCONNECTING/CONNECTING LIMIT SWITCH in PROCEDURE 6 of this manual.

Refer to INSTALLING/REMOVING FOOTRESTS or INSTALLING/REMOVING ELEVATING LEGRESTS or PREPARING REMOVABLE FOOTBOARD FOR WHEELCHAIR TRANSPORTATION in PROCEDURE 3 of this manual.

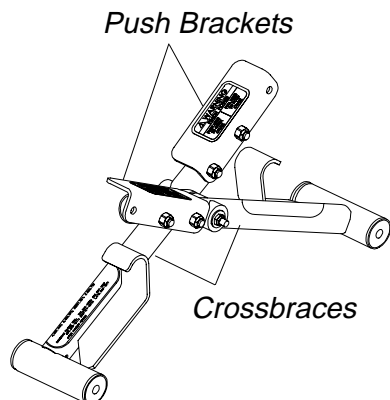

**FIGURE 2 - TRANSPORTING RANGER II MWD - CAPTAIN'S SEATS**

2. Remove the Captain's Seat. Refer to REMOVING/INSTALLING CAPTAIN'S SEAT in PROCEDURE 5 of this manual.
3. Remove the shrouds. Refer to REMOVING/INSTALLING SHROUDS in PROCEDURE 9 of this manual.
4. Remove the batteries, battery tray and footrests/legrests/footboard plate from the wheelchair. Refer to FIGURE 2.
5. Lift up on push brackets located on the crossbraces.

**WHEN TO CHARGE BATTERIES (FIGURE 3)**

It is advantageous to recharge daily rather than only when necessary. In fact, a battery's life is extended if the charge level is maintained well above a low condition.

**MKIV RII Joystick**

**BATTERY DISCHARGE INDICATOR (BDI)** is located at the front of the joystick housing and provides information on the remaining charge in the batteries. At FULL charge the BDI will be GREEN. As the battery becomes discharged, the BDI indicator will turn AMBER (YELLOW), then RED and finally FLASHING RED. If the BDI is FLASHING RED, the user should charge the batteries as soon as possible.

*NOTE: Accurate readings are displayed when in neutral.*

**MCC-MKIV X, A or A+ Joystick**

**BATTERY GAUGE DISPLAY (BGD)** is the bar graph display located on the MKIV X, A or A+ joystick. It will keep you informed as to power availability. A visual warning is given before the power becomes too low to operate the wheelchair. At full charge the two (2) LEFT segments and the farthest RIGHT segment of the bar graph will be illuminated. As the battery becomes discharged, the farthest RIGHT segment will progressively move to the LEFT until only the last two (2) bars (LEFT) are illuminated. At this level the last two (2) bars (LEFT) will start to Flash ON and OFF to indicate that the end user should charge the batteries as soon as possible.

*NOTE: Accurate readings are displayed when in neutral.*

*Battery Discharge Indicator (BDI)*

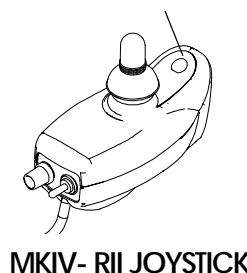

**MKIV- RII JOYSTICK**

*Battery Gauge Display (BGD)*

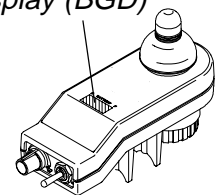

**MKIV X, A OR A+ JOYSTICK**  
*NOTE: MKIV X Shown.*

**FIGURE 3 - WHEN TO CHARGE BATTERIES**

**CHARGING BATTERIES (FIGURE 4)**

M  
W  
D  
W  
H  
E  
E  
L  
C  
H  
A  
I  
R  
S

**WARNING**

Never attempt to recharge the batteries by attaching cables directly to the battery terminals or clamps. Use the recharging plug located either on the side/rear of the wheelchair frame or on the front of the joystick.

DO NOT attempt to recharge the batteries and operate the power wheelchair at the same time.

During use and charging, unsealed batteries will vent hydrogen gas which is explosive in the right concentration with air.

**CAUTION**

Always charge new batteries fully BEFORE initial use or battery life will be reduced.

*NOTE: As a general rule, batteries should be recharged daily to assure the longest possible life and minimize the required charging time. Plan to recharge the batteries when it is anticipated the wheelchair will not be used for several days.*

The range per battery charge using recommended batteries should be approximately 5 to 9 hours of typical operation. Extensive use on inclines or age of batteries may substantially reduce per charge mileage.

**Description and Use of Battery Chargers**

The charger automatically reduces the amount of charge from an initially high rate to a zero reading at a fully charged condition.

**SHUTOFF PROCEDURE.**

- A. **For Models RANGER II<sub>BASIC</sub> and RANGER II<sub>STANDARD</sub>** -If left unattended, the charger will automatically shut-off when full charge is obtained.
- B. **For RANGER II<sub>250 SERIES</sub>** -The Charger output and green light will stay ON until the power switch on the battery charger is moved to the OFF position.

**There are some basic concepts which will help you understand this automatic process:**

The amount of electrical current drawn within a given time to charge a battery is called "charge rate". If, due to usage, the charge stored in the battery is low, the charge rate is high. **(FOR MODELS RANGER II<sub>BASIC</sub> and RANGER II<sub>STANDARD</sub>** - this is indicated by the green light on the charger. Initially, the green light will stay illuminated for a short period of time followed by a longer period of off time.)

As a charge builds up, the charge rate is reduced, and the following will occur:

- A. **For Models RANGER II<sub>BASIC</sub> and RANGER II<sub>STANDARD</sub>** - the green light will stay illuminated for a longer period of time followed by a shorter off time.
- B. **For Model RANGER II<sub>250 SERIES</sub>** - the battery charger rate decreases to a "trickle charge".

*NOTE: If performing the charging procedures independently, READ and CAREFULLY follow the individual instructions for each charger (supplied or purchased).*

*NOTE: If charging instructions are not supplied, consult a qualified service technician for proper procedures.*

**Required Items:**

TOOL	QUANTITY	COMMENTS
Battery Charger	1	Supplied
⊕ Extension Cord	1	Not Supplied

⊕ 3-prong plug, 15 ampere current rating; industrial type

**Wheelchairs Equipped With MCC-Mark IV Joystick (Detail "A" of FIGURE 4)**

1. If necessary, remove the rear shroud. Refer to REMOVING/INSTALLING SHROUDS - MWD WHEELCHAIRS in PROCEDURE 9 of this manual.
2. Attach the battery charger connector to the charger cable/battery harness.
3. Plug the charger's AC power cord, or extension, into the grounded 120 VAC wall outlet.
4. Wait until charging is complete.

*NOTE: Allow eight (8) hours for normal charging. Larger batteries (greater than 55 ampere-hours) or severely discharged batteries may require up to sixteen (16) hours to be properly charged and equalized.*

*NOTE: RANGER II<sub>BASIC</sub> and RANGER II<sub>STANDARD</sub> ONLY - If the charger operates for sixteen (16) hours and is unable to fully charge the batteries, an internal timer turns the charger off and begins to fast blink the green light.*

*NOTE: If the batteries need to be charged more often or take longer to charge than normal, they may need to be replaced. Contact an authorized dealer for service.*

5. If necessary, install the rear shroud. Refer to REMOVING/INSTALLING SHROUDS - MWD WHEELCHAIRS in PROCEDURE 9 of this manual.



**Wheelchairs Equipped With Mark IV RII Joystick (Detail "B" of FIGURE 4)**

1. Attach the battery charger connector to the charger port on the FRONT of the joystick.
2. Plug the charger's AC power cord, or extension, into the grounded 120 VAC wall outlet.
3. Wait until charging is complete.

*NOTE: Allow eight (8) hours for normal charging. Larger batteries (greater than 55 ampere-hours) or severely discharged batteries may require up to sixteen (16) hours to be properly charged and equalized.*

**DETAIL "A"**

Battery Charger Connector (on Side of Wheelchair)

WHEELCHAIRS WITHOUT SHROUDS

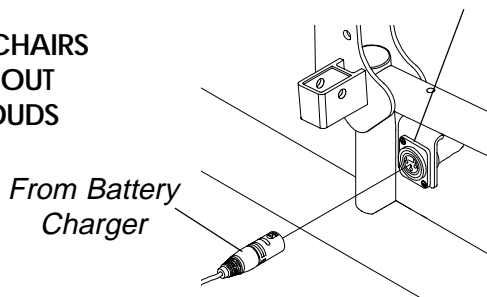

WHEELCHAIRS WITH SHROUDS

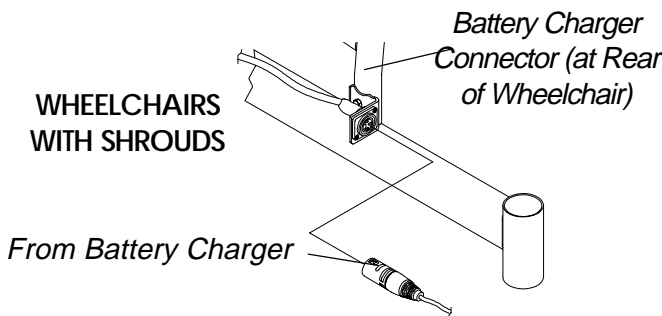

**DETAIL "B"**

Battery Charger Three (3) Pronged Plug

Front View of Joystick

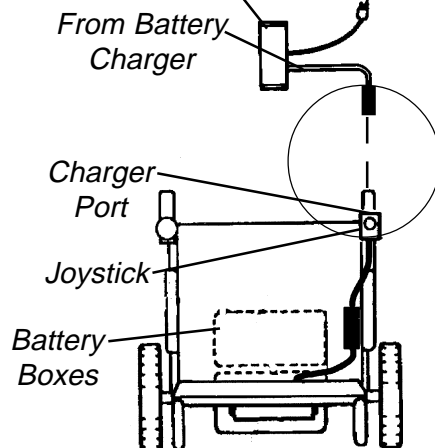

Charger Port

**REPLACING BATTERIES**

**WARNING**

Most batteries are not sold with instructions. However, warnings are frequently noted on the cell caps. Read them carefully, otherwise injury or damage can occur.

*NOTE: Invacare recommends that both batteries be replaced if one (1) battery is defective.*

**Recommended Battery Types**

**WARNING**

The warranty and performance specifications contained in this manual are based on the use of deep cycle gel cell or sealed lead acid batteries. Invacare strongly recommends their use as the power source for this unit.

**CAUTION**

Failure to use the correct battery size and/or voltage may cause damage to your wheelchair and give you unsatisfactory performance.

CHAIR SEAT WIDTH	QTY	VOLTS	*BATTERY SIZE	REMARKS
16,18,20-inches	2	12	22NF	Deep Cycle

*\*NOTE: RANGER II<sub>250</sub> SERIES requires U1 gel cell batteries.*

1. Remove the battery boxes from the wheelchair. Refer to REMOVING/INSTALLING BATTERY BOXES in this procedure of the manual.
2. Remove existing batteries from the battery boxes. Refer to INSTALLING/REMOVING BATTERIES INTO/FROM BATTERY BOXES in PROCEDURE 10 of this manual.
3. Clean the new battery terminals.
4. Install the new batteries into the battery boxes. Refer to INSTALLING/REMOVING BATTERIES INTO/FROM BATTERY BOXES in PROCEDURE 10 of this manual.

**Cleaning Battery Terminals**

**WARNING**

DO NOT allow the liquid in the battery to come in contact with skin, clothes or other possessions. It is a form of acid and harmful or damaging burns may result. Should the liquid touch your skin, wash the area immediately and thoroughly with cool water. In serious cases or if eye contact is made, seek medical attention IMMEDIATELY.

NEVER smoke or strike a match near batteries. If the caps of the battery cells are removed, NEVER look directly into them while charging batteries.

FIGURE 4 - CHARGING BATTERIES

1. Examine battery clamps and terminals for corrosion.
  2. If applicable, verify that the plastic caps are in place over the battery cell holes.
  3. Cut the tie wraps around the terminal caps/covers.
  4. Slide the terminal cap/cover up the wire to expose the battery terminal.
  5. Clean the terminals and inside the battery clamps by using a battery cleaning tool, wire brush, or medium grade sand paper.
- NOTE: When done, these areas should be shiny, not dull.*
6. Carefully dust off all metal particles.
  7. Slide the terminal cap/cover back down the wire to cover the battery terminal.
  8. Secure the terminal cap/cover using NEW tie wraps.
3. Position the battery boxes onto the battery tray in the following order:
    - A. FRONT Battery Box.
    - B. REAR Battery Box.
  4. Position retaining straps around each battery box as shown in DETAIL "A" of FIGURE 7 and clip retaining strap together.
- NOTE: Make sure battery box leads are on the same side as battery connectors on wheelchair frame.*
5. Connect the battery box leads to the battery connectors on the wheelchair frame.
  6. If necessary, reinstall the removeable footboard. Refer to PREPARING THE REMOVEABLE FOOTBOARD FOR WHEELCHAIR TRANSPORTATION in PROCEDURE 3 of this manual.

**INSTALLING/REMOVING BATTERY BOXES (FIGURE 5)**

*NOTE: To remove the battery boxes from the wheelchair, reverse the following procedure.*

*NOTE: If the wheelchair is equipped with the removeable footboard AND it is installed in the highest position, it is necessary to remove the footboard plate BEFORE removing the battery boxes. Refer to PREPARING THE REMOVEABLE FOOTBOARD FOR WHEELCHAIR TRANSPORTATION in PROCEDURE 3 of this manual.*

*NOTE: Motors should be in the engaged position when removing/installing batteries. Refer to ENGAGING/DISENGAGING MOTORS in PROCEDURE 8 of this manual.*

1. Verify that the ON/OFF switch on the joystick is in the OFF position.
2. If necessary, remove the front and rear shrouds. Refer to REMOVING/INSTALLING SHROUDS in PROCEDURE 9 of this manual.

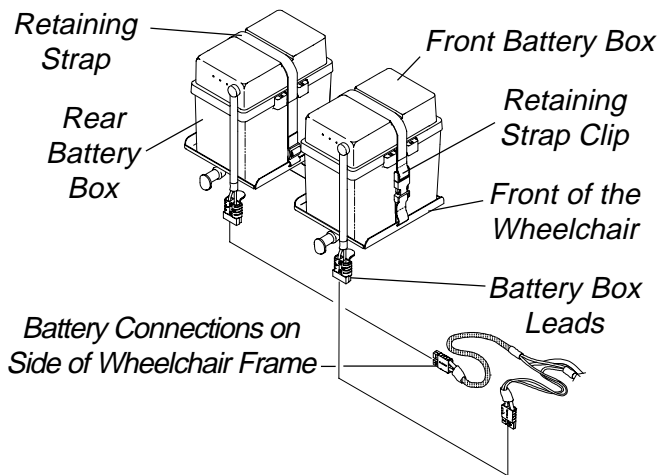

FIGURE 5 - INSTALLING/REMOVING BATTERY BOXES

**WARNING**

Battery boxes MUST be installed/removed in the order stated below or the battery tray could rotate causing the rear battery box to fall possibly causing injury or damage.

Use extreme care when installing/removing the battery boxes.

NEVER unplug the battery cables by pulling on the wires. Unplug the battery cables by pulling on the connector ONLY. Otherwise injury or damage may result.

When removing the battery boxes from the wheelchair, remove the rear battery box first.

## ADJUSTING THE STABILIZER (FIGURE 6)

1. With the batteries and the user in the wheelchair, grasp the swing arm and pull up. Clearance between the stabilizer wheel and the surface should be 1/8-inch or greater. If the clearance is less than 1/8-inch contact Invacare Dealer for service. See DETAIL "A".

### Additional Adjustments for User Preference (DETAIL "B")

1. Rotating the locknut that is located on top of the lower spring provides one (1) of the following:
  - A. **Rotating the locknut CLOCKWISE** - provides more resistance of the stabilizer when stopping.
  - B. **Rotating the locknut COUNTER-CLOCKWISE** - provides less resistance of the stabilizer when stopping.

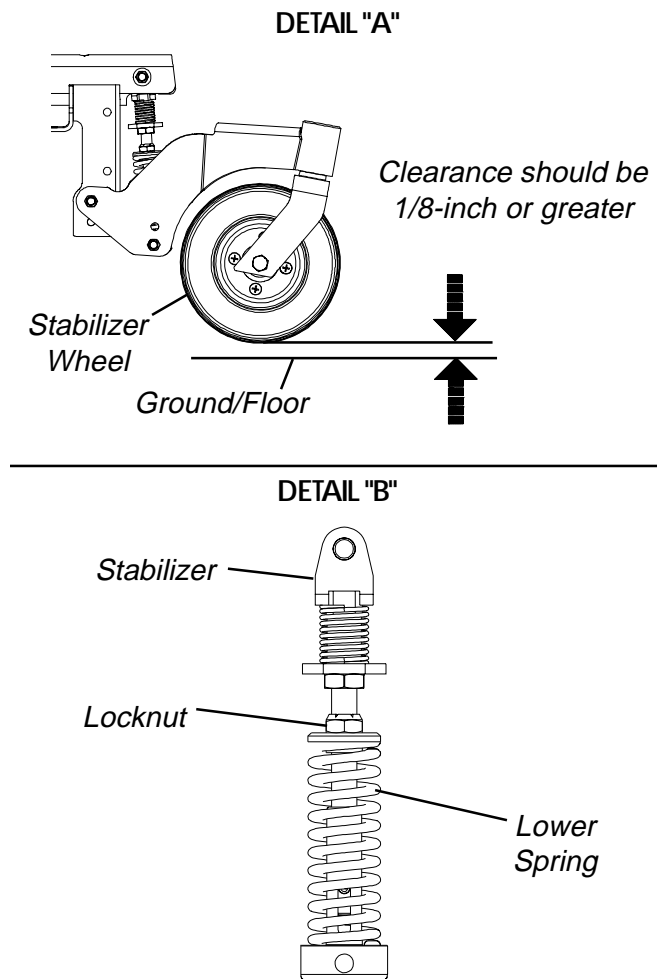

FIGURE 6 - ADJUSTING THE STABILIZER

## BATTERY TRAY (FIGURE 7)

### Installing Battery Tray

1. If necessary, remove the shrouds. Refer to REMOVING/INSTALLING SHROUDS - MWD WHEELCHAIRS in PROCEDURE 9 of this manual.

2. Turn the battery tray slightly to one (1) side.

*NOTE: Make sure the end of the battery tray labeled "FRONT" is towards the front of the wheelchair.*

3. Position the battery tray pins over the mounting slots on the hanger brackets.

**WARNING**

Make sure pins of battery tray are secure in the mounting slots of the hanger bracket, otherwise injury or damage may result.

4. Push down on the battery tray to secure in place.
5. Install the battery boxes. Refer to INSTALLING/REMOVING BATTERY BOXES in this procedure of the manual.
6. If necessary, install the shrouds. Refer to REMOVING/INSTALLING SHROUDS - MWD WHEELCHAIRS in PROCEDURE 9 of this manual.

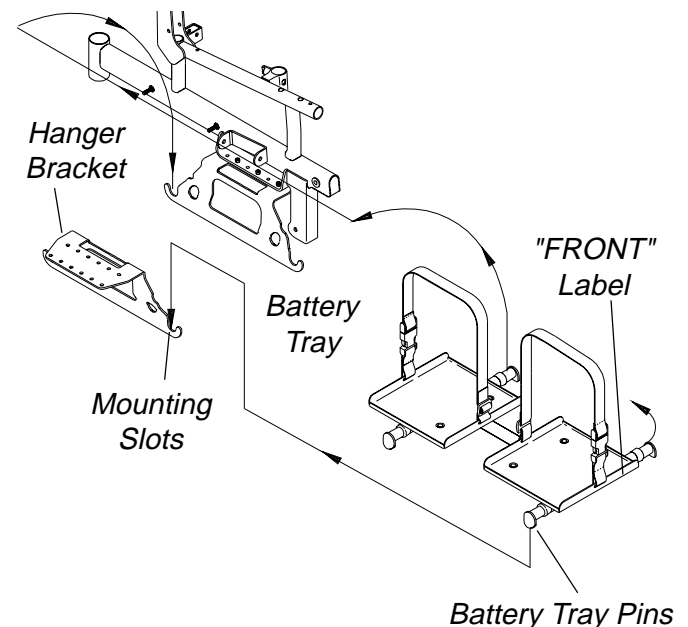

FIGURE 7 - BATTERY TRAY

## LIMITED WARRANTY

PLEASE NOTE: THE WARRANTY BELOW HAS BEEN DRAFTED TO COMPLY WITH FEDERAL LAW APPLICABLE TO PRODUCTS MANUFACTURED AFTER JULY 4, 1975.

This warranty is extended only to the original purchaser/user of our products.

This warranty gives you specific legal rights and you may also have other legal rights which vary from state to state.

With regards to the original purchaser/user only, Invacare warrants the side frames and crossbraces to be free from defects in materials and workmanship for a period of five (5) years from date of purchase; electronics for a period of one (1) year from the date of purchase; motors and gearboxes for a period of eighteen (18) months for Ranger II models with motors that have motor locks and a period of twelve (12) months for Ranger II models with motors that have clutches from the date of purchase; all remaining components (including gas cylinders for recliners) for one (1) year from the date of purchase except upholstered materials, padded materials and tires/wheels. If within such warranty period any product shall be proven to be defective, such product shall be repaired or replaced, at Invacare's option. This warranty does not include any labor or shipping charges incurred in replacement part installation or repair of any such product. Invacare's sole obligation and your exclusive remedy under this warranty shall be limited to such repair and/or replacement.

For warranty service, please contact the dealer from whom you purchased your Invacare product. In the event you do not receive satisfactory warranty service, please write directly to Invacare at the address on the bottom of the page. Provide dealer's name address, date of purchase, indicate nature of the defect and, if the product is serialized, indicate the serial number. Do not return products to our factory without our prior consent.

**LIMITATIONS AND EXCLUSIONS:** THE FOREGOING WARRANTY SHALL NOT APPLY TO SERIAL NUMBERED PRODUCTS IF THE SERIAL NUMBER HAS BEEN REMOVED OR DEFACED, PRODUCTS SUBJECT TO NEGLIGENCE, ACCIDENT, IMPROPER OPERATION, MAINTENANCE OR STORAGE, COMMERCIAL OR INSTITUTIONAL USE, PRODUCTS MODIFIED WITHOUT INVACARE'S EXPRESS WRITTEN CONSENT INCLUDING, BUT NOT LIMITED TO, MODIFICATION THROUGH THE USE OF UNAUTHORIZED PARTS OR ATTACHMENTS; PRODUCTS DAMAGED BY REASON OF REPAIRS MADE TO ANY COMPONENT WITHOUT THE SPECIFIC CONSENT OF INVACARE, OR TO A PRODUCT DAMAGED BY CIRCUMSTANCES BEYOND INVACARE'S CONTROL, AND SUCH EVALUATION WILL BE SOLELY DETERMINED BY INVACARE. THE WARRANTY SHALL NOT APPLY TO PROBLEMS ARISING FROM NORMAL WEAR OR FAILURE TO ADHERE TO THESE INSTRUCTIONS. A CHANGE IN OPERATING NOISE, PARTICULARLY RELATIVE TO MOTORS AND GEARBOXES DOES NOT CONSTITUTE A FAILURE. ALL SUCH DEVICES WILL EXHIBIT A CHANGE IN OPERATING NOISE DUE TO AGING.

THE FOREGOING WARRANTY IS EXCLUSIVE AND IN LIEU OF ALL OTHER EXPRESS WARRANTIES. IMPLIED WARRANTIES, IF ANY, INCLUDING THE IMPLIED WARRANTIES OF MERCHANTABILITY AND FITNESS FOR A PARTICULAR PURPOSE, SHALL NOT EXTEND BEYOND THE DURATION OF THE EXPRESSED WARRANTY PROVIDED HEREIN AND THE REMEDY FOR VIOLATIONS OF ANY IMPLIED WARRANTY SHALL BE LIMITED TO REPAIR OR REPLACEMENT OF THE DEFECTIVE PRODUCT PURSUANT TO THE TERMS CONTAINED HEREIN. INVACARE SHALL NOT BE LIABLE FOR ANY CONSEQUENTIAL OR INCIDENTAL DAMAGES WHATSOEVER.

THIS WARRANTY SHALL BE EXTENDED TO COMPLY WITH STATE/PROVINCIAL LAWS AND REQUIREMENTS.

Invacare Corporation

[www.invacare.com](http://www.invacare.com)



**Yes, you can.™**

**USA**  
One Invacare Way  
Elyria, Ohio USA  
44036-2125  
800-333-6900

**Canada**  
5970 Chedworth Way  
Mississauga, Ontario  
L5R 3T9, Canada  
905-890-8838

Invacare and Storm Series are registered trademarks of Invacare Corporation.  
Yes, you can. and Ranger II are trademarks of Invacare Corporation.

©2001 Invacare Corporation  
Form No. 98-272 Part No. 1080722

Rev H (I) - 4/01

## Free Manuals Download Website

<http://myh66.com>

<http://usermanuals.us>

<http://www.somanuals.com>

<http://www.4manuals.cc>

<http://www.manual-lib.com>

<http://www.404manual.com>

<http://www.luxmanual.com>

<http://aubethermostatmanual.com>

Golf course search by state

<http://golfingnear.com>

Email search by domain

<http://emailbydomain.com>

Auto manuals search

<http://auto.somanuals.com>

TV manuals search

<http://tv.somanuals.com>