

NVS 6 PILOT NIGHT VISION GOGGLES MAINTENANCE AND OPERATION MANUAL

In USA: 3310 Prospect Ave. Cleveland, OH 44115

In Canada: 1183 Finch Ave. W., Suite 302, Toronto, ON M3J 2G2 Canada

Tel: (416) 663-6963 Fax: (416) 663-9065

Email: NEWCONSALES@NEWCON-OPTIK.COM

Web: <http://WWW.NEWCON-OPTIK.COM>

NVS 6 MANUAL

IMPORTANT INFORMATION

Read prior to activation

You have just purchased a complicated electronic device. To operate it properly, please read this manual carefully. Here are some common precautions that must be noted.

- **NEVER** disassemble the unit. This device contains high voltage, which may be hazardous to your health!
- **NEVER** expose the opened objective lens of an active unit in daylight. At daytime objective lens must be covered by caps. There is a tiny hole in the cap to provide enough light for daytime testing. It is allowed to turn on the unit at daytime, but caps must cover the lenses.
- **NEVER** aim active unit at intense light sources (i.e. lights, headlamp, campfires, the moon, etc.)
- **NEVER** reverse the polarity of a battery
- **ALWAYS** remove batteries when not in use for a long period
- **ALWAYS** keep the objective lenses covered when not in use
- **ALWAYS** store in a warm dry place when not in use

NVS 6 MANUAL

RECORD OF REVISIONS

Rev. No.	Section, Sub-Section, Subject	Page			Authorizing Document No.	Transmittal letter Reference No. and date	Signed by	Date
		Revised	Added	Deleted				

NVS 6 MANUAL

LIST OF EFFECTIVE PAGES

Section, Sub-Section, Subject	Page	Date	Section, Sub-Section, Subject	Page	Date
Title Page	–	–		23	
Record of Revisions	1/2			24	
List of Effective Pages	1/2			25	
Table of Contents	1/2			26	
General	1			27	
	2			28	
Main Data	3			29	
	4			30	
Standard Set	5			31	
	6			32	
Safety Precautions	7		Operation Procedure	33	
Design of Unit and Its Components	8			34	
	9		Operational Status Check	35	
	10		Trouble Shooting	36	
	11			37	
	12			38	
	13			39	
	14			40	
	15		Maintenance Practices	41	
	16			42	
	17			43	
	18			44	
Preparation for Operation	19			45	
	20		Storage and Shipment	46	
	21			47	
	22			48	
				49	
				50	

NVS 6 MANUAL

TABLE OF CONTENTS

	Page
1 General	1
2 Main Data	3
3 Standard Set.....	5
4 Safety Precautions.....	7
5 Design of Unit and Its Components	8
6 Preparation for Operation	19
6.1 Preparation of Helmet for Mounting Night-Vision Goggles	19
6.2 Individual Adjustment and Fitting.....	22
6.3 Arrangement of Night-Vision Goggles on Helicopter	32
7 Operation Procedure	36
8 Operational Status Check.....	38
9 Trouble Shooting	40
10 Maintenance Practices	44
11 Storage and Shipment.....	49
APPENDIX A	51
APPENDIX B	52

NVS 6 MANUAL

1 General

1.1 The NVS 6, helicopter night-vision goggles, have been designed for use by the helicopter crewmembers during execution of flights at night.

Note – The helicopter cockpit should be tailored for the use of the night-vision goggles. Accounting for the spectral content of the light equipment radiation, color of the cockpit interior surfaces, and the like.

1.2 The NVS 6 provides napping off the earth while piloting the helicopter at low altitudes, at takeoff, hovering and landing, including landing on unprepared and non-illuminated landing sites.

1.3 When using the NVS 6, the pilot can take the readings of the instruments by looking at the instrument panel in the downward direction or sideways past the eyepieces.

1.4 The NVS 6 operates within the ambient temperature range of minus 40 to +40°C.

1.5 The power supply to the NVS 6 is powered by the helicopter electrical system of 27V, via the voltage converter or from the independent power source (IPS). The IPS is built-in to the goggles and consisting of two batteries of type size AA R6 1.5V or from rechargeable batteries of the same type.

Note – The IPS (independent power source) is used when the aircraft electrical power is lost or the helicopter power supply has failed.

1.6 The NVS 6 shall be used under the following conditions:

- When the natural night illumination intensity is within $5 \cdot 10^{-3}$ to 1 lx and the meteorological visibility is 1 to 10 km
- At a flight altitude of 20 to 200 m;
- At a flight speed of up to 120 km/h.

NVS 6 MANUAL

1.7 The trouble-free operation of the NVS 6, within the assigned service life, is ensured through its correct use, careful handling and well-timed maintenance.

1.8 When operating the unit or placing it in storage, keep it clean and avoid touching the external optical surfaces of the lenses and eyepieces with fingers. Protect the unit against impact or dropping which may cause damage and defects to the unit and render it inoperable.

1.9 Before using the NVS 6, carefully read this Manual.

1.10 In the course of the service of the unit, enter the information pertaining to its operational status, maintenance, storage and repair in the Log Book.

NVS 6 MANUAL

2 MAIN DATA

2.1 Specifications of the NVS 6 are presented in Table 1.

Table 1

Specification	Characteristic
1 Field of view (FOV), minimum	40 deg
2 Magnifying power	1 X
3 Resolving power limit of the image intensifier tube, as measured in the center of FOV, minimum	50 lines per mm
4 Dioptric setting range of eyepieces, minimum	-6/+2 D
5 Interpupillary distance range	52 to 72.7 mm
6 Lens focusing distance range	0.25 m to infinity
7 Power supply: – From helicopter DC electrical system via a voltage converter – From two batteries of type size AA R6 1.5 V or rechargeable batteries	24.0 to 29.4 V 2.2 to 3.2 V
8 Current consumed with the unit powered from helicopter electrical system, maximum	100 mA
9 Power consumed with the unit powered from helicopter electrical system, maximum	3 W
10 Continuous operation time of the unit powered from the built-in independent power source without changing the batteries (within the entire operating temperature range), minimum	3 h

NVS 6 MANUAL

Table 1, cont'd

Specification	Characteristic
11 Continuous operation time followed by an interval of not less than 30 min, minimum	3 h
12 Unit deployment time (getting the unit ready for use), maximum	5 min
13 Unit stowing time (packing the unit in the case), maximum	5 min
14 Mass, maximum: <ul style="list-style-type: none">– Night-vision goggles (without mount)– Voltage converter with cable	0.59 kg 0.3 kg
15 Night-vision goggles overall dimensions, maximum	108x151.5x122 mm

NVS 6 MANUAL

3 STANDARD SET

3.1 The standard set of the NVS 6 shall be consistent with Table 2 and Fig. 3.1.

Table 2

Designation	Nomenclature	Qty	Remarks
<u>Assemblies</u>			
201211.010	Night-vision goggles	1	
433739.003	Voltage converter	1	
<u>Set of Spare Parts</u>			
279376.002	Dehydrator cartridge	1	Optional
<u>Set of Tools and Accessories</u>			
	Watchmaker's screwdriver MT-992, size 1.5	1	Optional
754421.001	Test pattern	1	Optional
	Batteries of type size AA R6 1.5 V	4	Optional
304134.001	Mount	1	
745159.003	Casing	1	
745159.001	Clamp	1	
305259.001	Counterweight	1	
741112.013	Cloth	3	Optional
<u>Packaging</u>			
325371.009	Soft Padded Case	1	

NVS 6 MANUAL

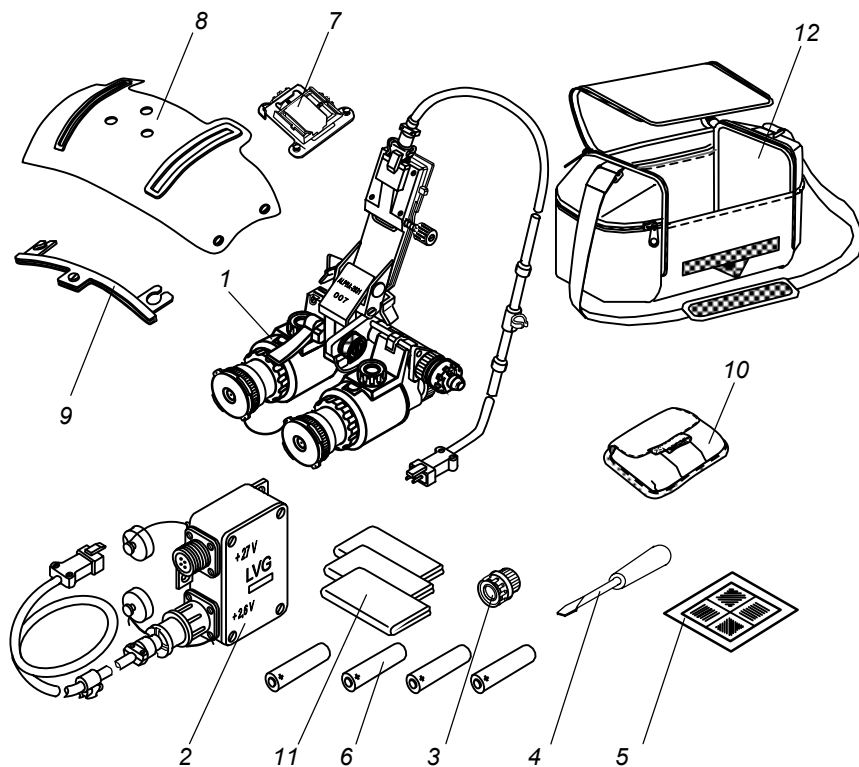

- | | | | |
|---|----------------------|----|---------------|
| 1 | Night-Vision Goggles | 7 | Mount |
| 2 | Voltage Converter | 8 | Casing |
| 3 | Dehydrator Cartridge | 9 | Clamp |
| 4 | Screwdriver | 10 | Counterweight |
| 5 | Test Pattern | 11 | Cloth |
| 6 | Batteries | 12 | Case |

NVS 6 Standard Set

Figure 3.1

NVS 6 MANUAL

4 SAFETY PRECAUTIONS

4.1 The NVS 6 is constructed so as to provide pilot's safety during operation.

4.2 In case of emergency the helicopter crewmembers shall take off (throw off) the NVS 6 night-vision goggles before evacuating the helicopter.

To ensure successful removal of the unit, the crewmember using the NVS 6 in flight should be trained to quickly execute the night-vision goggles. In an emergency evacuation from the helicopter expedient removal is essential for his/her safety.

4.3 Care should be taken to protect the unit from direct exposure of its lenses to high-level optical radiation.

CAUTION: NEVER SWITCH ON THE UNIT DURING DAY LIGHT UNLESS PROTECTIVE CAPS ARE INSTALLED ON THE UNIT LENSES. DO NOT KEEP THE UNIT IN THE BRIGHT LIGHT SOURCES FOR LONG PERIODS OF TIME.

NVS 6 MANUAL

5 DESIGN OF UNIT AND ITS COMPONENTS

5.1 The NVS 6 is essentially a passive-type optoelectronic night-vision device whose principle of operation is based on the intensification of image brightness of objects being viewed with the aid of image-intensifier tubes.

5.2 The NVS 6 design employs a binocular pattern, i.e. it consists of two identical optoelectronic channels (of monocular type) which afford stereoscopic vision to create comfortable conditions for napping off the earth, thus enabling the pilot to evaluate the space depth and ensure higher night flight safety.

5.3 The general view of the NVS 6 is illustrated in Fig. 5.1.

5.3.1 Lenses (1) may be focused either relative to distant objects located in the space outside the cockpit, or relative to the objects located close to the helicopter. The focus is adjusted by rotating the lenses.

5.3.2 The dioptric focusing of eyepieces (2) is carried out individually for each sight channel of the unit by rotating eyepieces with the aid of focusing rings (3).

5.3.3 The independent power source (IPS) is arranged inside guide (4), which is closed with cap-switch (5).

5.3.4 The NVS 6 is installed onto the pilot's helmet by attachment of fixing assembly (6) of the unit to mount (7), which is then secured to helmet casing (8).

The fixing assembly makes it possible to perform individual adjustment, so as to provide the most comfortable position of the goggles mounted on the helmet relative to the pilot's eyes. This feature enables the pilot to move the goggles away from the eyes, tilt the optical axes of monocular pair and displace them upwards and downwards.

NVS 6 MANUAL

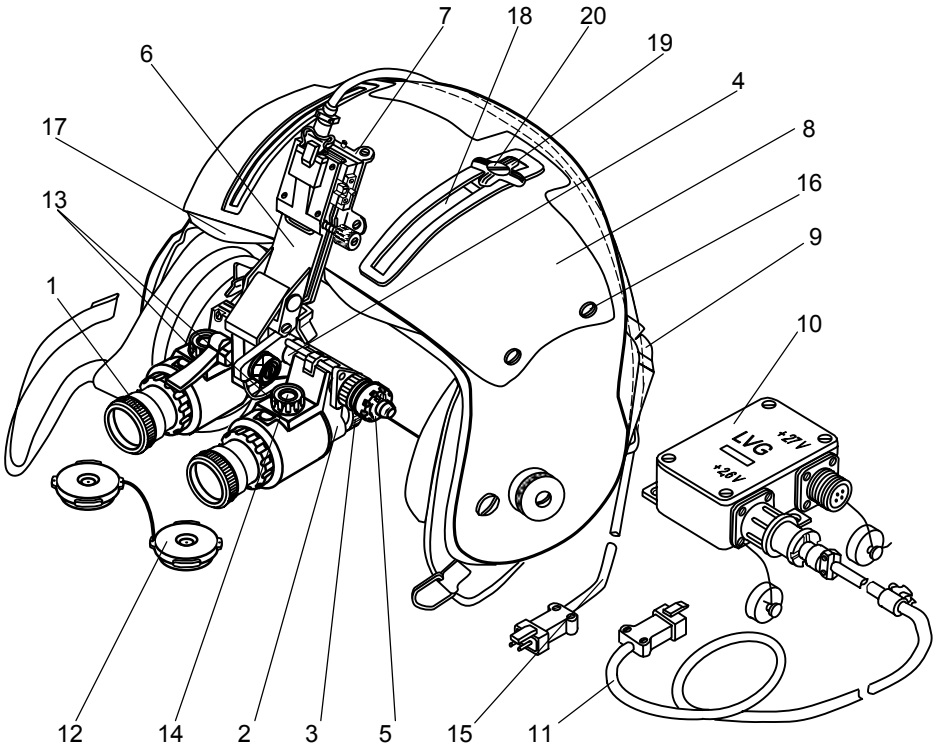

- | | |
|--------------------------------|-------------------------|
| 1 Lens | 11 Cable |
| 2 Eyepiece | 12 Cap |
| 3 Ring | 13 Dehydrator Cartridge |
| 4 Guide | 14 Sight Glass |
| 5 Cap-Switch | 15 Cable |
| 6 Fixing Assembly | 16 Screw |
| 7 Mount | 17 Visor Guard |
| 8 Casing | 18 Slot |
| 9 Counterweight | 19 Cross-Shaped Knob |
| 10 LVC (Low-Voltage Converter) | 20 Screw |

NVS 6
Figure 5.1

NVS 6 MANUAL

For balancing out the overturning momentum produced by the unit in the operating position, use is made of counterweight (9) secured on the rear portion of the helmet.

The helmet should be tailored for employment of the night-vision goggles. For this purpose, the standard casing should be replaced and the strip of the sticking fastener should be bonded to the helmet rear surface for attachment of the counterweight (the necessary appliances are included in the set of spare parts).

Note: other helmets may require different mounting mechanisms

5.3.5 Caps (12) are intended to safeguard the image intensifier tubes against exposure to light and protect the optical components of the lenses from mechanical damage.

The caps are provided with holes for checking the night-vision goggles for serviceability at an illumination intensity of more than 1 lx (in conditions of day light and dusk), as well as with retainers (two spring-loaded projections located on the cap sides) used for reliable locking of the cap in the mount of lens (1).

Small projections in the sides of the cap are provided, with holes for joining the caps, in pairs by means of a fishing line. This will minimize their inadvertent loss in service.

5.3.6 The moisture-resistance of the unit is ensured with the use of annular rubber seals and dehydrator cartridges (13). These are intended to absorb moisture in case it gets into the interior space of the monocular pair. The dehydrator cartridge is filled with silica gel that is bluish in color when it is not saturated. As the silica gel gets saturated, it turns rose-pale or off-white. The external condition of the silica gel is monitored through sight glass (14).

5.4 The NVS 6 standard set comprises the night-vision goggles, the voltage converter and the single set of spare parts. (Optional)

NVS 6 MANUAL

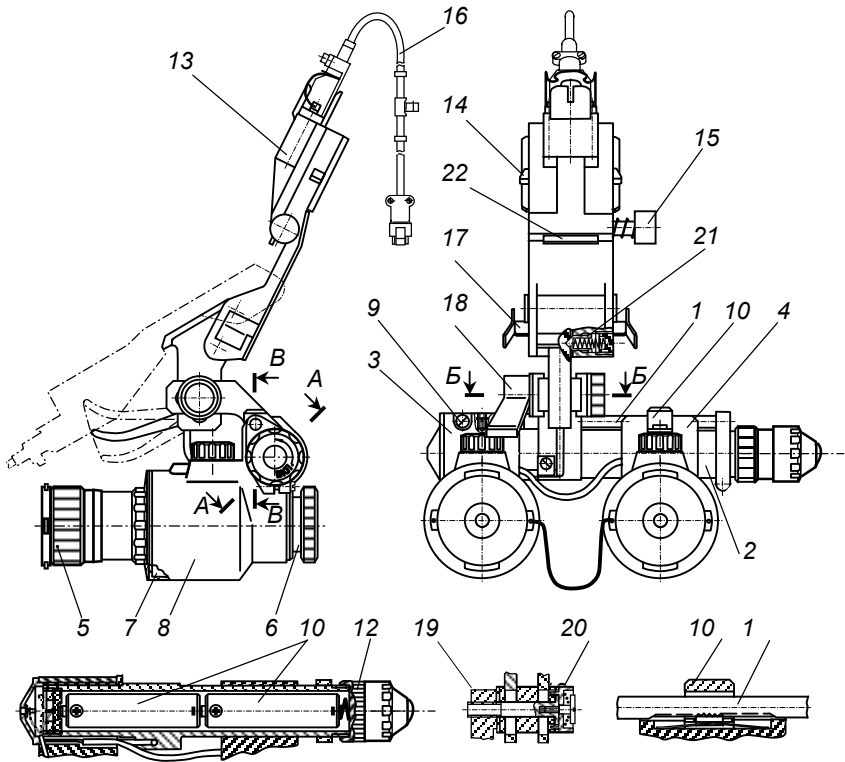

- | | | |
|--------------------------|--------------------|-------------|
| 1 Guide | 9 Screw | 16 Cable |
| 2 Guide | 10 Button | 17 Lever |
| 3 RH Side Monocular | 11 Batteries | 18 Knob |
| 4 LH Side Monocular | 12 Cap-switch | 19 Screw |
| 5 Lens | 13 Fixing Assembly | 20 Plate |
| 6 Eyepiece | 14 Retainer | 21 Retainer |
| 7 Image-Intensifier Tube | 15 Button | 22 Retainer |
| 8 Barrel | | |

Night-Vision Goggles

Figure 5.2

NVS 6 MANUAL

Physically, the night-vision goggles are made in the form of two identical electro-optical channels – monocular (3) and monocular (4) – which are mechanically linked with each other with the aid of guide (1) and guide (2). Each of the monocular pair incorporates lens (5), eyepiece (6), image-intensifier tube (7) and barrel (8).

RH side monocular (3) that allows the pilot to carry out observation with the right eye is rigidly fastened to guide (2), while LH side monocular (4) that permits observation with the left eye is of a movable design and may be displaced to adjust the eyepieces of the night-vision goggles to suit the pilot's eyes.

To adjust the night-vision goggles interpupillary distance, depress button (10) and displace monocular (4) along guide (2) to set it to the desired position. These done, release the button to fix monocular (4) in the selected position.

Batteries (11) are installed inside guide (2) and closed with cap-switch (12).

The night-vision goggles are attached to the helmet with the aid of the guides of fixing assembly (13) and those of the helmet mount. The fixing assembly is retained in the fixed position in the helmet mount by means of retainer (14).

The transfer of the night-vision goggles from the stowed position to the operating one, in which they are fitted on the helmet, is accomplished by depressing button (15) with the left hand and lowering the goggles until they are retained in the locked position. The fixing assembly is provided with a connector, for connecting the mating connector plug of cable (16), intended to feed power to the night-vision goggles via the voltage converter.

Upon termination of use, the night-vision goggles are easily removed complete with cable (16) from the mount of the helmet by pressing down lever (17).

NVS 6 MANUAL

Knob (18) provides a means of individual adjustment of the monocular position (eye relief, tilt of the monocular pair optical axes, and displacement of the monocular pair in the upward and downward directions).

The monocular pair is locked in the selected position by moving the knob down as far as it will go. This securely locks the monocular pair in this position. The force applied for tightening the knob is adjustable. This adjustment is performed after releasing the hinged joint by turning screw (19) about its axis. To carry out the adjustment, pull out plate (20) that retains the screw in position and turn it complete with the screw to the next fixed position. In so doing, remember that the knob retaining force becomes greater as the plate is turned clockwise and vice versa.

The night-vision goggles can be promptly removed from the pilot's field of view and transferred to the stowed position.

To do so, take hold of the monocular pair and, while overcoming the force of retainer (21), move it fully upwards to the stowed position. As the monocular pair is brought to a stop, the retainer will operate to hold it up in the stowed position.

The electrical circuits, in this case, will become automatically de-energized through activation of the microswitch.

5.4.2 Voltage converter (2) is illustrated in Fig. 3.1.

The voltage converter is designed to supply power to the NVS 6 from the helicopter electrical system.

The voltage converter consists of two separate components: low-voltage converter (LVC) (10) and cable (11) as shown in Fig. 5.1.

The LVC is a stabilized DC power source used to convert the helicopter electrical power of 27V DC to 2.6V DC to power the unit.

NVS 6 MANUAL

The design of the LVC is illustrated in Fig. 5.3. Structurally, the LVC consists of casing (1), which accommodates voltage converter (2) attached to it by means of screws (3). Cover (4) is fastened to the casing with screws (5). Connector plug (6) serves to connect the LVC to the helicopter electrical system of 27 V with the aid of the cable arranged on board the aircraft.

Connector receptacle (7) is intended to connect cable (11), shown in Fig. 5.1, to the LVC.

Connector plug (6) and connector receptacle (7) are secured to the casing by means of screws (8) as shown in Fig. 5.3.

Gaskets (9) installed between the casing, the connector plug and the receptacle serve to protect the LVC interior against direct entry of moisture, whereas LVC cover (4) is filled with sealing compound for the same purpose. Cable (11) attached to the voltage converter is connected to cable (15) to make an electric power supply circuit of the night-vision goggles as shown in Fig. 5.1.

The use of cables with quick-disconnect connectors makes it possible to promptly remove the night-vision goggles from the helmet in case of emergency.

5.5 Apart from spare dehydrator cartridge, the single set of spare parts includes the following: test pattern, mount, casing, clamp, counterweight, screwdriver, cloth, spare batteries or rechargeable batteries. Spare parts availability is optional, to be specified in each individual supply contract.

5.5.1 Test pattern (5), shown in Fig. 3.1, is designed for checking the quality of the image of the NVS 6 (resolving power). The check procedure is presented in 6.2.21 of this Manual.

5.5.2 The mount, shown in Fig. 5.4, is intended to secure the NVS 6 on the helmet of the pilot or a helmet of a similar type.

NVS 6 MANUAL

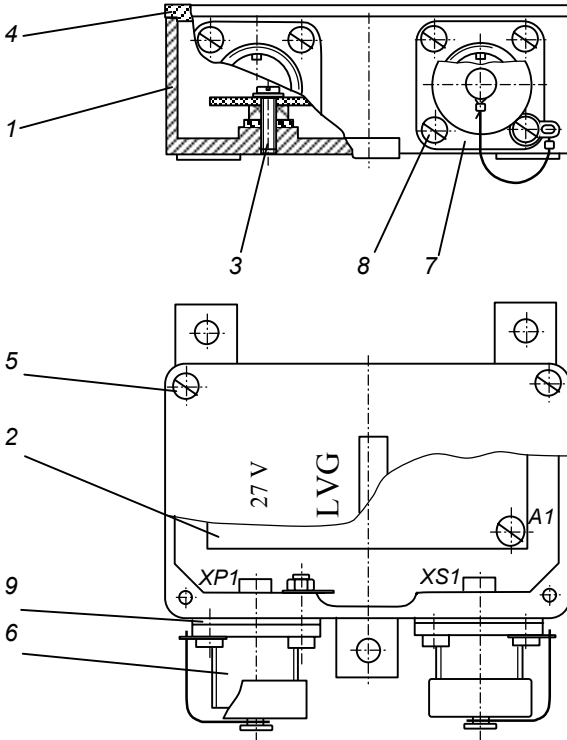

- | | | |
|---------------------|------------------|------------------------|
| 1 Casing | 4 Cover | 7 Connector Receptacle |
| 2 Voltage Converter | 5 Screw | 8 Screw |
| 3 Screw | 6 Connector Plug | 9 Gasket |

Low-Voltage Converter
Figure 5.3

NVS 6 MANUAL

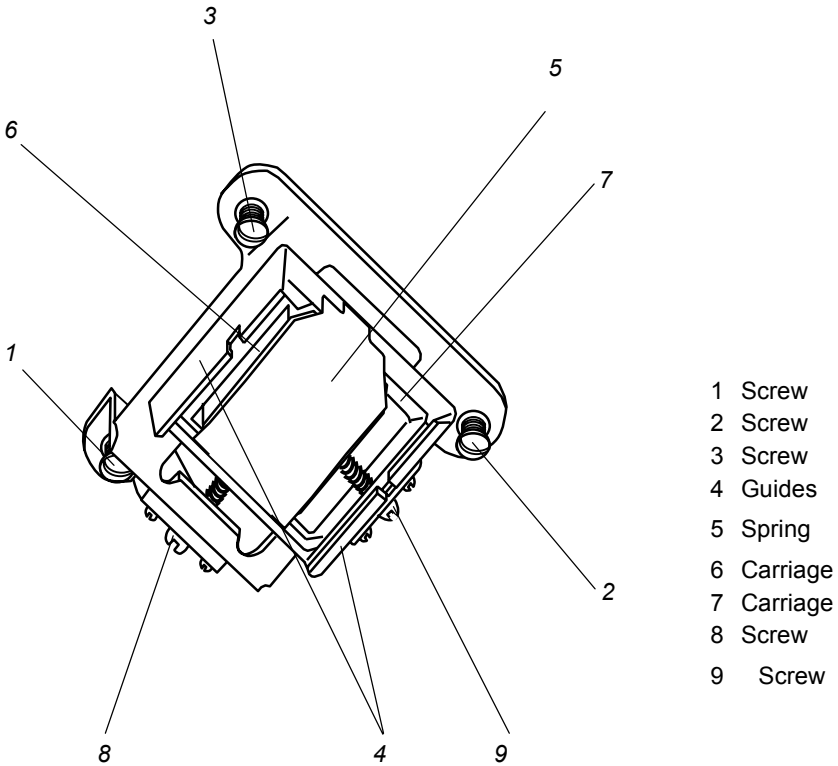

Mount
Figure 5.4

The mount is attached to the front portion of the helmet with the aid of three screws (1), (2), (3).

The night-vision goggles are secured to the mount by means of a night-vision goggle plate, which is passed into the slots of guides (4) of the mount.

The purpose of spring (5) is to reliably retain the NVS 6 on the mount.

NVS 6 MANUAL

Carriages (6) and (7) can be moved upwards/downwards by rotating adjustment screw (8), as well as left/right with the aid of screw (9) to adjust the position of the night-vision goggles relative to the pilot's eyes. The adjustment is performed with the use of the screwdriver, part of the single set of spare parts.

5.5.3 Casing (8), shown in Fig. 3.1, is intended for replacing the helmet standard casing, which makes it possible to fasten the night-vision goggles. Three holes provided at the casing center are used for installation of mount (7) as shown in Fig. 5.1. After attaching the casing on the external surface of the helmet front portion with four screws (16), it protects visor guard (17) against any possible damage. Slots (18) are used as guides when lowering and lifting the visor guard. They help to hold the visor guard in the required position with the use of retainer cross-shaped knob (19) moving along the slot of the casing, together with the visor guard. While replacing the casing, the retainer cross-shaped knob can be installed for using by the right or left hand of the pilot.

5.5.4 Clamp (9), shown in Fig. 3.1, is meant for fastening the visor guard when replacing the standard casing for the casing found in the set of spare parts. The clamp together with the visor guard fastened in it is attached to the casing with the help of the retainer shown in Fig. 6.1.

5.5.5 Counterweight (10), shown in Fig. 3.1, is intended to compensate for the tilting momentum produced by the unit.

The counterweight is essentially an individual assembly consisting of a canvas cover with a weight contained therein. As shown in Fig. 5.1, counterweight (9) can be quickly installed on the rear portion of the helmet through the use of the sticking fastener. The mass of the counterweight is 620 g.

The counter weight also has a strap with a sticking fastener used for securing night-vision goggles power cable (15).

NVS 6 MANUAL

5.5.6 Screwdriver (4), shown in Fig. 3.1, is meant for performing necessary readjustments of mount (7) and also used when the helmet standard casing is replaced.

5.5.7 For removing dust, moisture and dirt from the external surfaces of the unit, use is made of cloth (11) shown in Fig. 3.1.

5.5.8 The rechargeable batteries included in the single set of spare parts, serve for replacement of failed or exhausted batteries of the independent power source. The rechargeable batteries are charged by the use of a standard battery charging unit designed for charging the AA type rechargeable batteries in accordance with the Manual furnished with the charging unit.

5.6 The packaging components of the NVS 6 include the case and the set of maintenance documents (the Manual and the Log Book).

5.6.1 The case, shown in Fig. 3.1, is used for storing and carrying the NVS 6 set. The case is provided with side pockets, which are fastened with a zipper. One pocket holds the LVC (low-voltage converter) and the cables, and the other one is used for holding the mount, counterweight and screwdriver. The inner pocket is intended for accommodating the test pattern, cloths, spare dehydrator cartridge and batteries or rechargeable batteries. The night-vision goggles and its accessories are delivered sealed in a polyethylene film envelope, which is packed in the case together with the casing and clamp. The case is closed with a flap fastened with a zipper and a sticking fastener. The case comes complete with a carrying strap.

NVS 6 MANUAL

6 PREPARATION FOR OPERATION

6.1 Preparation of Helmet for Mounting Night-Vision Goggles

6.1.1 Replacement of Visor Guard/Mount Assembly

6.1.1.1 Remove the standard mount assembly of visor guard (17) (Ref. Fig. 5.1). To do this, remove four screws (16) attaching the casing to the helmet using the screwdriver found in the set of spare parts.

6.1.1.2 To disconnect the visor guard from the standard casing:

(a) Remove screw (20) with the screwdriver by turning it clockwise.

(b) Remove cross-shaped knob (19) by hand.

(c) Remove retainer (1) (Ref. Fig. 6.1) together with the visor guard from the standard casing slot.

(d) Remove the visor guard from the retainer by first turning retainer tail end (2) along the visor guard slot.

6.1.1.3 Take clamp (9) shown in Fig. 3.1 from the set of spare parts.

6.1.1.4 Remove screw (3) with the screwdriver as shown in Fig. 6.2 and remove bushing (4) from the clamp hole.

6.1.1.5 insert the visor guard into clamp slot (5) accurately without turning askew and applying much force, and fasten it using a bushing and a screw.

6.1.1.6 Take casing (8) out of the set of spare parts. Connect the clamp, together with the visor guard secured in it, to the casing. To do this, insert retainer tail end (2) along recess (6) of the clamp (left-hand or right-hand at the option of the pilot) and turn it crosswise the recess as shown in Fig. 6.2.

6.1.1.7 Pass the retainer threaded portion through the respective (left-hand or right-hand) slot of casing (8) and proceed as in Steps 6.1.1.2 (b), 6.1.1.2 (a) and 6.1.1.1 observing the mentioned order.

NVS 6 MANUAL

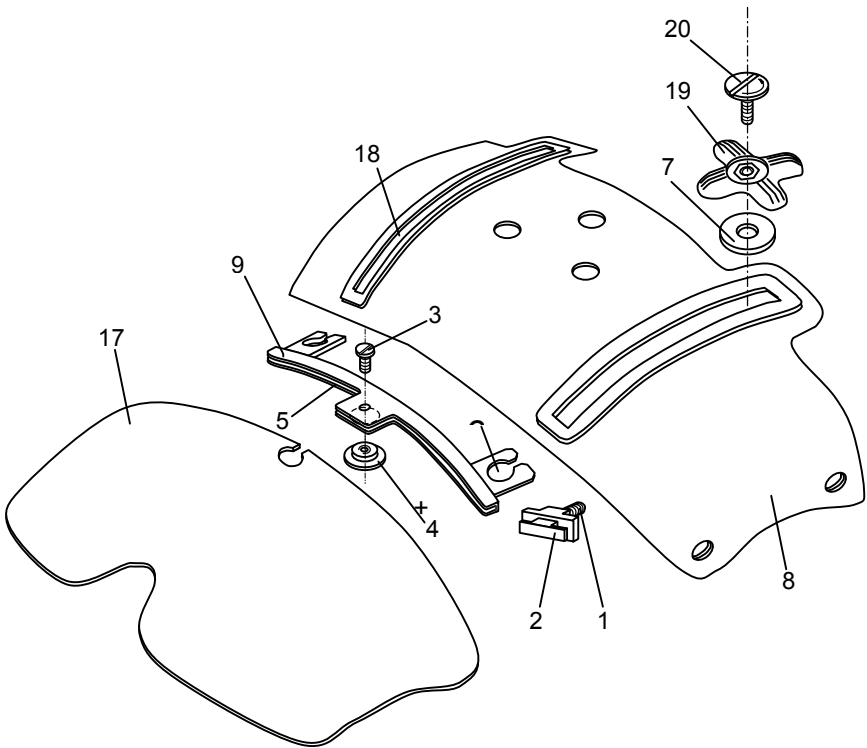

- | | | |
|------------|----------|----------------------|
| 1 Retainer | 6 Recess | 17 Visor Guard |
| 2 Tail End | 7 Washer | 18 Slot |
| 3 Screw | 8 Casing | 19 Cross-shaped Knob |
| 4 Bushing | 9 Clamp | 20 Screw |
| 5 Recess | | |

Replacement of Casing on Helmet
Figure 6.1

NVS 6 MANUAL

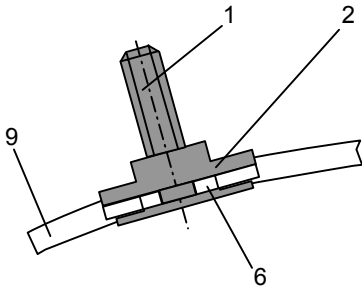

- 1 Retainer
- 2 Tail End
- 6 Recess
- 9 Clamp

Assembly of Clamp with Retainer

Figure 6.2

6.1.2 Installation of Counterweight

6.1.2.1 Take counterweight (10) (Ref. Fig. 3.1) from the set of spare parts, remove the backing of the sticking fastener meant for fastening to the helmet.

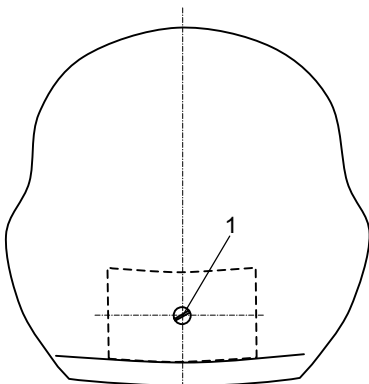

Figure 6.3

6.1.2.2 Bond the removed fastener to the rear portion of the helmet external surface so that the hole made at the center of the fastener coincides with screw head (1) (Fig. 6.3), the lower edge of the fastener therewith should join to the helmet rubber edging. Before bonding with adhesive trace the outline of the fastener on the helmet and thoroughly remove the paint from the helmet within the outline.

NVS 6 MANUAL

6.1.2.3 The adhesive recommended for usage is acrylate cyanide, type LOCTITE 454, or the like providing an adequate bonding of fiberglass laminate with polyvinyl chloride (the adhesive sets in 2 to 3 min and the unit may be used after a lapse of 24 h). For the bonding procedure, refer to the Instructions for Cement Usage.

6.1.2.4 While bonding the fastener press its smooth side to the helmet surface evenly without applying an excessive force. Apply pressure to the fastener total area and use a screw clamp for locking the parts to be bonded (Uniformly press the sticking fastener against the helmet until its strip is bonded to the helmet, use should be made of the suitable device).

6.2 Individual Adjustment and Fitting (Figs 6.4 thru 6.6)

CAUTION: EACH PILOT SHOULD CARRY OUT INDIVIDUAL FITTING AND ADJUSTMENT OF THE NIGHT-VISION GOGGLES.

Before starting the adjustment check to see that the lenses are closed with safety caps.

6.2.1 Remove the night-vision goggles from the case.

6.2.2 Depress button (1) (Ref. Fig. 6.4) and, while holding the fixing assembly in one hand, take monoculars (28) and (29) in the other hand, transfer the goggles to the operating position so that the fixing assembly is straightened. In doing so, see that only a slight force is applied to securely lock (latch) the monocular pair in the operating position, indicated by a click of retainer (21) (Ref. Fig. 5.2).

CAUTION: IN THE EVENT OF FAILURE OF THE RETAINER TO LATCH THE MONOCULAR PAIR IN THE OPERATING POSITION, THE NIGHT-VISION GOGGLES WILL NOT BE ENERGIZED AND THE INDIVIDUAL ADJUSTMENT WILL NOT BE POSSIBLE.

6.2.3 To ensure proper latching, essential for retaining the monocular pair in the operating position, check to see that the hinged joint linking the monocular pair to the unit fixing assembly is reliably locked.

NVS 6 MANUAL

Should the monocular pair fail to be locked relative to the unit fixing assembly, proceed as follows:

- Move knob (2) (Ref. Fig. 6.4) to the top position (the hinged joint, in this case, will be fully released).

- Pull out plate (3), which retains screw (4) in the locked position, with your thumb and forefinger, turn it to the next locking position in the clockwise direction and release the plate. The plate shall be set to a new locking position (Ref. Step 6.2.2).

- This done, lock the hinged joint linking the monocular pair to the unit fixing assembly again by applying an effort to knob (2) so as to bring it down as far as it will go.

If the monocular locking continues to fail, carry out the above procedure one more time.

6.2.4 Take power supply components (two batteries of type size AA R6 1.5V or rechargeable batteries) out of the case. When using the rechargeable batteries, first charge them in accordance with the Manual furnished with the battery-charging unit.

6.2.5 Insert two batteries into the recess of guide (8) with the positive contact directed inwards by first unscrewing and removing cap-switch (5), and then screw it in fully in the clockwise direction.

6.2.6 Release knob (2) and set the top portion of the fixing assembly perpendicular to the axes of monocular (28) and monocular (29). While holding the fixing assembly in one hand, displace the monocular pair with the other hand forward and downward until they are butted up against the cruciform guides of the fixing assembly. Once completed, tighten the knob to lock the monocular pair in the desired position.

WARNING: NEGLECT OF THE REQUIREMENTS DESCRIBED IN THE ABOVE STEP MAY RESULT IN EYE INJURY DURING THE COMPLETION OF FURTHER PREPARATORY OPERATIONS.

NVS 6 MANUAL

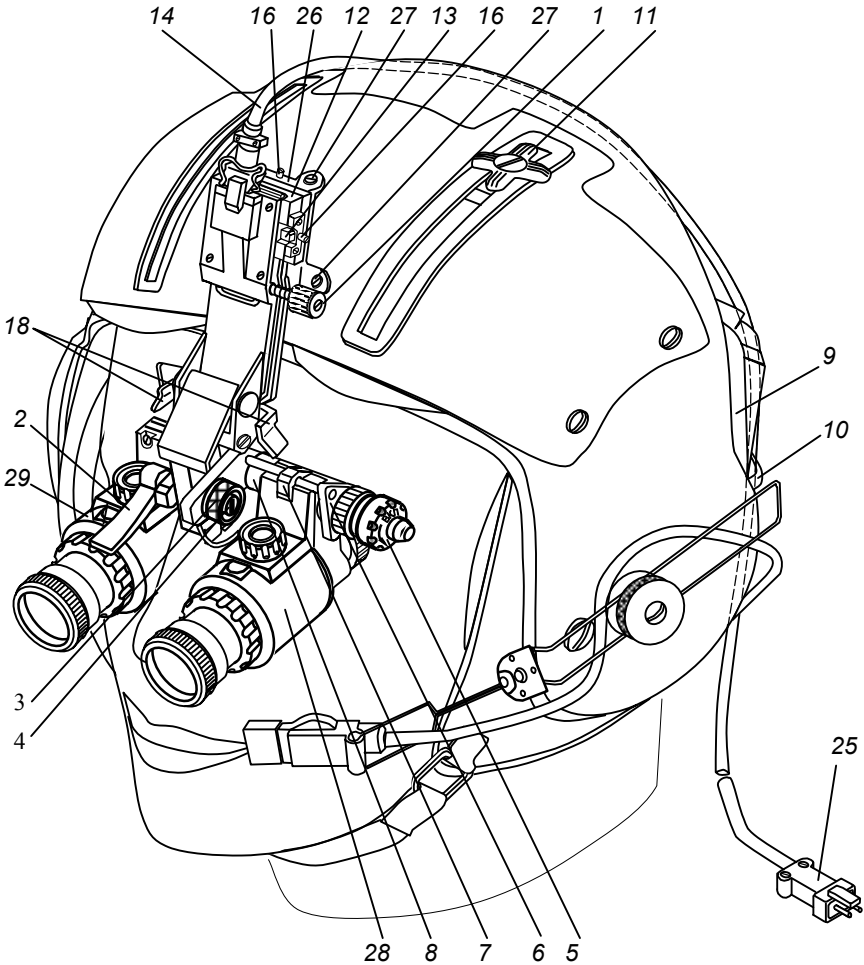

- | | | |
|--------------|--------------------|----------------------|
| 1 Button | 9 Counterweight | 16 Screw |
| 2 Knob | 10 Strap | 18 Lever |
| 3 Plate | 11 Cross-head Knob | 25 Connector |
| 4 Screw | 12 Guide | 26 Mount |
| 5 Cap-switch | 13 Retainer | 27 Screw |
| 6 Cap | 14 Cable | 28 LH Side Monocular |
| 7 Button | 15 Visor Guard | 29 RH Side Monocular |
| 8 Guide | | |

Installation of Night-Vision Goggles on Helmet in Operating Position
Figure 6.4

NVS 6 MANUAL

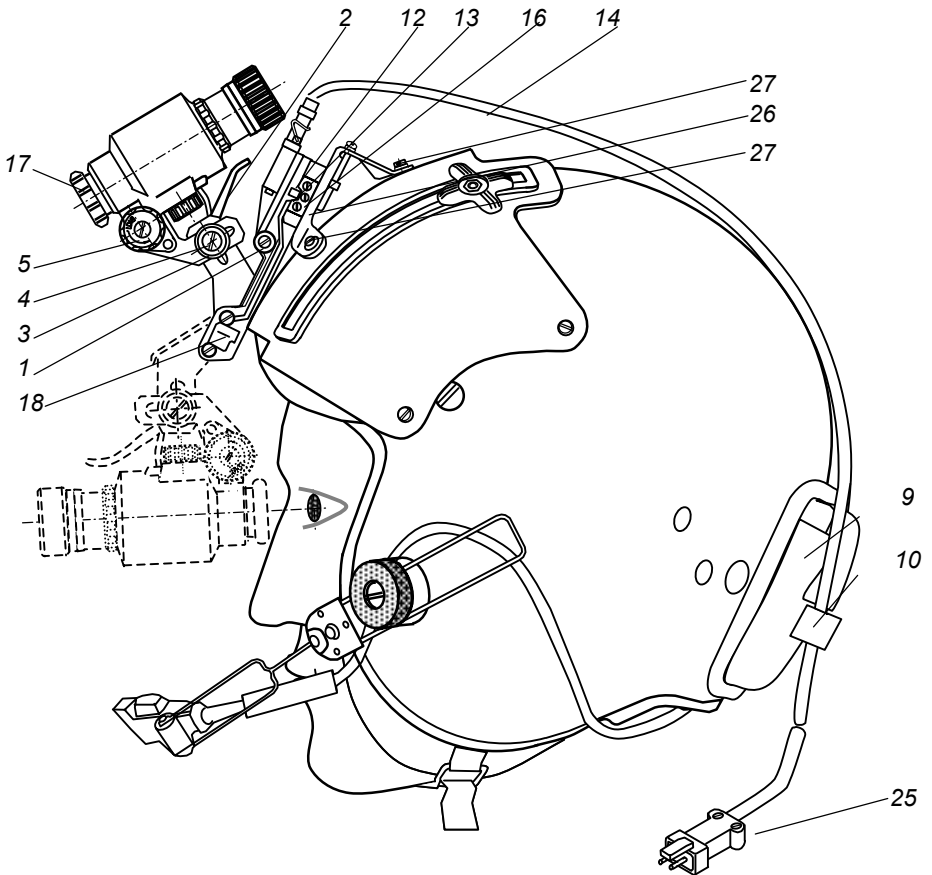

- | | | |
|-----------------|-------------|--------------|
| 1 Button | 10 Strap | 17 Ring |
| 2 Knob | 12 Guide | 18 Lever |
| 3 Plate | 13 Retainer | 25 Connector |
| 4 Screw | 14 Cable | 26 Mount |
| 5 Cap-switch | 16 Screw | 27 Screw |
| 9 Counterweight | | |

Night-Vision Goggles Installed on Helmet in Stowed Position

Figure 6.5

NVS 6 MANUAL

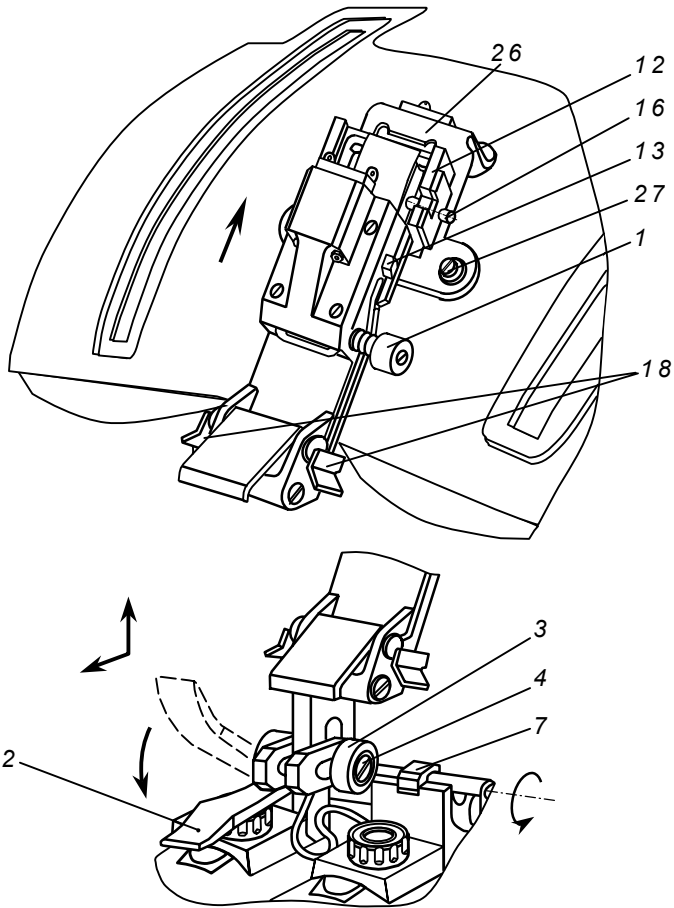

1 Button
2 Knob
3 Plate
4 Screw

7 Button
12 Guide
13 Retainer
16 Screw

18 Lever
26 Mount
27 Screw

Installation of Night-Vision Goggles on Helmet and Their Adjustment
Relative to Pilot's Eyes

Figure 6.6

NVS 6 MANUAL

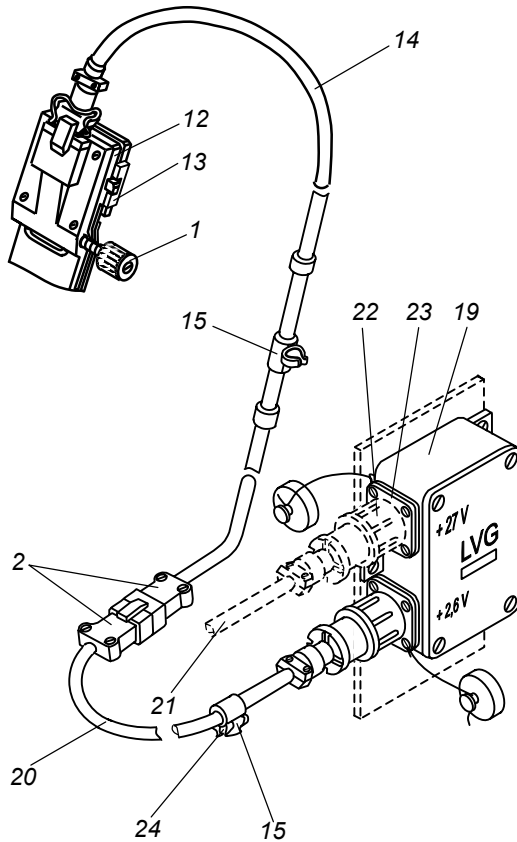

- | | | |
|-------------|--|-----------------|
| 1 Button | 19 LVC (Low-Voltage Converter) | 22 Receptacle |
| 12 Guide | 20 Cable | 23 Plug |
| 13 Retainer | 21 LVC Power Cable Running from Helicopter Electrical System | 24 Spring Clamp |
| 14 Cable | | 25 Connector |

Connection of Night-Vision Goggles to Helicopter Electrical System Via Voltage Converter

Figure 6.7

6.2.7 Position the eyepieces of the goggles at eye level, turn on the night-vision goggles by turning cap (6) of cap-switch (5) in the

NVS 6 MANUAL

counterclockwise direction until it is retained in the ON position and check to see that the unit operates properly. In so doing, see to it that the image-intensifier tube screens start glow steadily in amber-green (without flashes and twinkling) in the monocular pair of the night-vision goggles.

CAUTION: TO SAFEGUARD THE UNIT AGAINST DAMAGE, MAKE ABSOLUTELY SURE THAT THE SAFETY CAPS ARE FITTED ON THE LENSES WHEN THE NIGHT-VISION GOGGLES ARE TURNED ON IN THE PRESENCE OF LIGHT.

6.2.8 Depress button (7) and displace LH side monocular (28) with respect to the immobile RH side monocular, along guide (8) to preliminarily select the optimum distance between the eye pupils in accordance with the interpupillary distance of the operator. Release button (7) and the LH side monocular will be locked in the selected position.

6.2.9 Turn cap (6) of cap-switch (5) in the clockwise direction as far as it will go to de-energize the night-vision goggles.

6.2.10 Take hold of the monocular pair with one hand and the fixing assembly with the other hand, and transfer the night-vision goggles to the stowed position as shown in Fig. 6.5 (i.e. fold up the fixing assembly by overcoming the retainer force that locks the goggles in the operating position).

6.2.11 Remove mount (26), part of the single set of spare parts, designed for attaching the night-vision goggles, from the outer pocket of the case and install it on the front portion of the helmet. To do so, insert three screws (27) into the threaded holes in the helmet casing and tighten them.

6.2.12 Remove counterweight (9) (Ref. Fig. 6.4) from the outer pocket of the case, install it on the rear portion of the helmet and secure it by means of the sticking fastener.

NVS 6 MANUAL

6.2.13 Carry out preparatory operations on the pilot's helmet in compliance with the Manual. Loosen cross-shaped knob (11) and use it to move visor guard (15) fully so that the visor guard is retracted under the casing. These done, fix the visor guard in this position by tightening the cross-shaped knob.

6.2.14 Install the night-vision goggles, which are currently placed in the stowed position, onto the helmet (with the helmet removed from the head), by joining the fixing assembly of the night-vision goggles to the helmet mount. To do so, insert the plate of the fixing assembly of the night-vision goggles into the slots of guide (12) (Ref. Fig. 6.4) of helmet mount (26). Exercise due care to avoid misalignment, then, turn the plate upwards until retainers (13) become latched.

6.2.15 Attach cable (14) to the helmet by first passing it under unfastened strap (10) on counterweight (9) and then fasten the strap using the sticking fastener.

6.2.16 Secure the helmet, complete with the goggles placed in the stowed position, on the pilot's head.

6.2.17 Transfer the goggles to the operating position (Ref. Step 6.2.2 of this Manual) and turn them on (Ref. Step 6.2.7 of this Manual).

6.2.18 Set RH side monocular (29) precisely opposite the right eye of the pilot. To do so, ease up knob (2) and displace the monocular pair of the night-vision goggles in the cruciform guides of the fixing assembly upward or downward, forward or backward. Simultaneously turn them about the axis of knob (2) to find the optimum position at which the NVS 6 monocular pair is properly set away from the eyes and their optical axes have the required tilt.

By an optimum position of the monocular pair relative to the pilot's eyes, is meant, a position that provides adequate conditions for carrying out observation of the full field of view of the RH side monocular with the

NVS 6 MANUAL

right eye, as well as clear view of the surrounding space by shifting gaze downwards under the eyepieces of the night-vision goggles.

Note – If the RH side monocular of the night-vision goggles fails to be set to the position at which the sighting line of the pilot's eye passes through its center, the position of the RH side monocular shall be corrected by moving the night-vision goggles upwards or downwards, right or left relative to the helmet. To do so, the carriages of helmet mount (26) should be shifted by the adjustment of screws (16) utilizing the screwdriver provided (Ref. Fig. 6.6). On completion of the corrective actions, perform the operations described in this step once again.

6.2.19 Carry out the operations prescribed by Step 6.2.8 of this Manual to finally adjust the interpupillary distance.

Make sure that the full field of view of the night-vision goggles is provided for both eyes.

6.2.20 Adjust the eyepieces to the appropriate dioptric sighting by turning rings (17) (Ref. Fig. 6.5) of the eyepieces until a sharp structural image of the screens on the image-intensifier tubes is attained.

6.2.21 Evaluate the operational status of the night-vision goggles by checking the image quality (resolving power). For this purpose, take a test pattern, from the single set of spare parts and arrange it at a distance of an outstretched hand away from the lenses ((750 ± 16) mm). The settings of the night-vision goggles are considered to be normal if the test pattern lines are clearly visible and the check text is readable. Both monoculars should operate without flashes and twinkling.

CAUTION: THE SERVICEABILITY CHECK OF THE NIGHT-VISION GOGGLES SHALL BE ACCOMPLISHED IN THE PRESENCE OF LIGHT WITH THE LENSES COVERED BY THE SAFETY CAPS.

6.2.22 De-energize the night-vision goggles (Ref. Step 6.2.9 of this Manual).

NVS 6 MANUAL

6.2.23 Check the operation of the mechanism permitting emergency removal of the night-vision goggles from the helmet. To test, depress levers (18) (Ref. Fig. 6.4) of the fixing assembly with the thumb and forefinger and simultaneously pull the night-vision goggles promptly downwards. As the night-vision goggles become released from the guide on the helmet, keep on moving your hand to the left and right side to disengage the power cable from the helmet. The night-vision goggles shall easily separate from the mount of the helmet and remain in the pilot's hands.

Regardless of the position, operating or stowed, the night-vision goggles will be easily removed.

WARNING: THE NIGHT-VISION GOGGLE REMOVAL TO BE PERFORMED IN THE EVENT OF AN EMERGENCY ESCAPE FROM THE HELICOPTER MUST BE THOROUGHLY PRACTICED BY THE PILOT ON THE GROUND TO ENHANCE HIS SAFETY IF EMERGENCY ESCAPE FROM THE COCKPIT SHOULD BE NECESSARY.

6.2.24 Transfer the night-vision goggles to the stowed position as instructed in Step 6.2.10 of this Manual.

6.2.25 Take out the used batteries from the night-vision goggles.

6.2.26 Take off the helmet and detach counterweight (9).

6.2.27 Place the night-vision goggles into the case and put the counterweight into the outer pocket.

6.2.28 Discharge the rechargeable batteries, if any, and recharge them, using a standard charging unit designed for charging the rechargeable batteries of type size AA 1.5 V in accordance with the Manual furnished with the unit.

6.2.29 Place the batteries (including rechargeable batteries) into the inner pocket of the case.

NVS 6 MANUAL

6.3 Arrangement of Night-Vision Goggles on Helicopter (Figs 6.4 thru 6.7)

6.3.1 Remove the following components from the case (Ref. Fig. 3.1): night-vision goggles (1), batteries (6) (2 pcs), mount (7), counterweight (10), voltage converter (2) complete with LVC (low-voltage converter) (10) (Ref. Fig. 5.1), and cable (11).

6.3.2 Secure LVC (19) (Ref. Fig. 6.7) in the place allotted for it in the cockpit and connects it to the helicopter electrical system by making use of airborne power cable (21) (engage receptacle (22) with LVC plug (23)).

6.3.3 Attach cable (20) with the aid of spring clamps (24) in the cockpit.

6.3.4 Install mount (26) found in the single set of spare parts (Ref. Fig. 6.6, Step 6.2.11) onto the front portion of the helmet.

6.3.5 Install counterweight (9) (Ref. Fig. 6.5, Step 6.2.12) onto the rear portion of the helmet.

6.3.6 Insert batteries into the special recess on the night-vision goggles (Ref. Step 6.2.5 of this Manual) to ensure independent power supply of the goggles.

6.3.7 Install the night-vision goggles on the helmet (with the helmet removed from the head) in the stowed position (Ref. Fig. 6.5), for this purpose; join the fixing assembly of the night-vision goggles to mount (26) of the helmet (Ref. Fig. 6.6). Using extreme care, insert the fixing assembly plate of the night-vision goggles into the slots of guide (12) of helmet mount (26) avoiding misalignment and shift the plate upwards until retainers (13) become latched.

Prior to installation, the night-vision goggles shall be adjusted to fit the eyes of a pilot as instructed in Section 6.2 of this Manual.

NVS 6 MANUAL

6.3.8 Fasten cable (14) on counterweight (9) using strap (10) (Ref. Fig. 6.5, Step 6.2.15).

6.3.9 With the goggles placed in the stowed position secure helmet soundly on the pilot's head.

6.3.10 Connect cable (14) to cable (20) with the use of the connector (25) (Ref. Fig. 6.7).

6.3.11 Turn on the switch to apply the helicopter electrical power to the night-vision goggles.

6.3.12 Depress button (1) (Ref. Figs 6.4, 6.5) and, while holding the fixing assembly with one hand and taking hold of the monocular pair with the other hand, transfer the goggles to the operating position so that the fixing assembly becomes straightened. In doing so, see to it that only slight effort is applied for ensuring proper locking (latching) of the monocular pair in the operating position. Only an effort sufficient to cause operation of retainer (21) is necessary. (Ref. Fig. 5.2). The goggles will get energized.

This done, the pilot shall see amber-green illumination free from flashes and twinkling on the screens of both channels of the night-vision goggles, which is indicative of normal operation of the goggles powered from the helicopter electrical system.

Note – When the night-vision goggles are powered from the helicopter electrical system, they are energized and de-energized automatically in response to their transfer from the stowed to the operating position and vice versa irrespective of the position of cap (6) (Ref. Fig. 6.4) of cap-switch (5).

CAUTION: 1 WHEN THE NIGHT-VISION GOGGLES ARE SWITCHED ON IN THE PRESENCE OF LIGHT OR WITH THE WHITE FLOOD LIGHT TURNED ON, MAKE ABSOLUTELY SURE THAT THE SAFETY CAPS ARE FITTED ON THE LENSES TO PREVENT DAMAGE OF THE UNIT.

NVS 6 MANUAL

2 IF THE POWER SUPPLY OF THE GOGGLES FROM THE HELICOPTER ELECTRICAL SYSTEM IS NOT AVAILABLE, THEIR OPERATION MAY BE PROVIDED FROM THE INDEPENDENT BUILT-IN POWER SOURCE (TWO BATTERIES AA R6 1.5 V OR RECHARGEABLE BATTERIES OF A SIMILAR TYPE).

6.3.13 If the alignment of the monoculars of the night-vision goggles with respect to the eyes of the pilot is not accurate enough and the monocular pair is not adjusted to suit individual features of his eyesight, perform the adjustment operations as prescribed by Steps 6.2.19, 6.2.20 of this Manual.

Now the goggles are ready for work.

Upon completion of work with the goggles, carry out the following operations:

6.3.14 Take hold of the monocular pair with one hand and the fixing assembly with the other hand and transfer the night-vision goggles to the stowed position (i.e. "fold up" the fixing assembly by overcoming the force of the retainer which locks the goggles in the operating position).

6.3.15 Turn off the switch used for supplying power from the helicopter electrical system to the night-vision goggles.

6.3.16 Disconnect cable (14) (Ref. Fig. 6.7) from cable (20) by disengaging the connector (25).

6.3.17 Take off the helmet complete with the night-vision goggles installed and detach the counterweight from the helmet.

6.3.18 Remove the night-vision goggles from the helmet by pulling them down by hand, having pressed levers (18) (Ref. Fig. 6.4) to disengage the goggles fixing assembly plate from the guides of mount (26) of the helmet.

6.3.19 Remove screws (27) and remove mount (26) from the helmet.

6.3.20 Remove the used batteries from the night-vision goggles.

NVS 6 MANUAL

6.3.21 Disconnect power cable (21) (Ref. Fig. 6.7) of the helicopter electrical system from the LVC (low-voltage converter), and disengage cable receptacle (22) from plug (23) of the LVC.

6.3.22 Remove the LVC (complete with cable (20)).

6.3.23 Put the night-vision goggles into the case. Do not put the rechargeable batteries into the case.

6.3.24 Discharge and recharge the rechargeable batteries in conformity with the Instructions presented in the Manual furnished with the standard battery-charging unit.

6.3.25 Pack the batteries and the rechargeable batteries after being charged into the case.

NVS 6 MANUAL

7 OPERATION PROCEDURE

7.1 The conditions in which the night-vision goggles are operated have their own idiosyncrasy, which requires certain skills on the part of the pilot as the image of the terrain and objects visible through the night-vision goggles is monochromic and not very soft.

7.2 The night-vision goggles enable the pilot not only to nap off the earth but also view the instrument panel by taking a look downwards or sideways past the eyepieces.

CAUTION: WHEN THE NVS 6 IS USED AT NIGHT TIME, THE SAFETY CAPS SHALL BE REMOVED FROM THE LENSES.

7.3 For removing the safety caps, press simultaneously on both retainers and, while holding them depressed, take the cap off of the lens mount. Put the removed caps into the case pocket.

7.4 After removing the safety caps, focus the lenses of each monocular by rotating the lens about its optical axis so as to attain the sharp image of the viewed objects in the space outside the cockpit (for convenience of rotation each lens is provided with knurling).

7.5 In case that the airborne power supply is not available, turn on the independent power source to feed power to the night-vision goggles by turning cap (6) of cap-switch (5) (Ref. Fig. 6.4).

7.6 If the night-vision goggles become exposed to bright light, turn your head to divert the lenses sideways so as to bring the image of bright light sources outside the field of view.

7.7 In the event of fogging of the eyepieces of the night-vision goggles (low temperature), pull the goggles out of the operating position and wipe dry the external surfaces of the eyepieces with a cloth included in the single set of spare parts.

7.8 After long usage of the night-vision goggles on the pilot's head (more than 2.5 h), the pilot may feel a light fatigue in the neck muscles.

NVS 6 MANUAL

7.9 Upon completion of work with the night-vision goggles and after the helicopter landing, perform the operations prescribed by Steps 6.2.14 thru 6.2.25. If need be, clean the night-vision goggles and their accessories from dust, dirt and traces of moisture with the cloth included in the single set of spare parts.

7.10 The preparation of the night-vision goggles for the next flight consists in replacement of the rechargeable batteries used in flight with newly charged ones and accomplishment of operations in accordance with Table 5.

7.11 Prior to an emergency evacuation of the helicopter, depress levers (18) (Ref. Fig. 6.4) of the fixing assembly with the left (right) hand thumb and forefinger and promptly pull the night-vision goggles down. As the goggles become disengaged from the guide on the helmet, keep on moving your hand to the left or right side until the power cable gets disconnected from the helmet.

The subsequent operations shall be carried out in compliance with the "Helicopter Crew Instructions" that specify the procedures for the night-vision goggles usage during flights.

NVS 6 MANUAL

8 OPERATIONAL STATUS CHECK

8.1 In the course of the NVS 6 service, it is essential to continually carry out its inspection. The inspection shall be accomplished during all kinds of maintenance checks with the aim of determining the unit operational status, and detecting in due time its defects and their correction. The operational status of the unit is exemplified by its serviceability, completeness of its standard set, and readiness for use.

8.2 The list of the basic checks of the NVS 6 and its accessories for operational status (inspection procedures) is presented in Table 3.

Table 3

Procedure	Inspection method	Technical requirements
1 Unit standard set inspection for full complement	Check the standard delivery set against the list of the unit components in the Log Book.	The unit standard set shall comply with the standard delivery set specified in the NVS 6 Log Book.
2 External inspection of the unit and its accessories	Inspect the unit for external condition (visually).	The external surfaces of the unit and its accessories shall not be affected by cracks, dents, traces of corrosion and other defects. The lenses and eyepieces shall be free from cracks, spots of grease and dirt.
3 Serviceability test of the unit and its accessories	The procedure for serviceability test is described in Section 6 of this Manual.	With the unit energized (either from the helicopter electrical system via the voltage converter, or from

Table 3, cont'd

NVS 6 MANUAL

Procedure	Inspection method	Technical requirements
		IPS), the image-intensifier tube screens shall illuminate and, after dioptic adjustment of the eyepieces (Ref. Step 6.2.20) and focusing of the lenses (Ref. Step 7.4), nearby objects shall be clearly seen in the unit field of view.
4 Quality of image viewed by unit	The check is conducted by the pilot in the course of individual adjustment of the night-vision goggles (Ref. Step 6.2.21)	The unit shall provide for distinct identification of the test pattern lines in all four directions and easy reading of the check text, which is indicative of the fact that the unit is ready for use.

9 TROUBLE SHOOTING

9.1 Normal operation of the NVS 6 is substantiated by the following indications:

(a) Feasibility of observing the illumination of the screens (without flashes and twinkling) of each of the two image-intensifier tubes through the eyepieces.

(b) Clear visibility of nearby objects and the test pattern lines in the course of preflight preparation.

9.2 All these signs are indicative of the adequate operational status of the NVS 6 for ensuring its normal functioning.

9.3 The list of the most frequent and probable troubles of the NVS 6 is given in Table 4.

NVS 6 MANUAL

Table 4

Trouble and symptoms	Probable cause	Correction	Remarks
1 NVS 6 failure to operate (image-intensifier tube screens are not illuminated)	1 Polarity of connected rechargeable batteries is not observed	1 Remove rechargeable batteries and then fit them in so that the positive lead marked with "+" is directed inwards into guide (2) (Ref. Fig. 5.2)	Can be performed in the field
	2 Rechargeable batteries (batteries) are discharged or unserviceable	1 Charge rechargeable batteries on the battery charging unit as instructed in the Manual furnished with	Can be performed in the field

Trouble and symptoms	Probable cause	Remedy	Remarks
		The unit, or replace failed rechargeable batteries or batteries with serviceable ones included in the single set of	

NVS 6 MANUAL

Trouble and symptoms	Probable cause	Remedy	Remarks
		spare parts	
	3 Presence of moisture inside the unit	1 Replace dehydrator cartridge (13) (Ref. Fig. 5.1), by first inspecting the color of silica gel indicator through sight glass (14). Replace the silica gel, when its color is turned lilac or rosy	Can be performed in the field
	4 LVC or cable are out of order	1 Forward the unit for repair	To be performed at a repair shop or at Manufacturer's facilities
	5 Image-intensifier tube is out of order	1 Forward the unit for repair	To be performed at a repair shop or at Manufacturer's facilities

NVS 6 MANUAL

Trouble and symptoms	Probable cause	Remedy	Remarks
2 Image of viewed objects is not sufficiently sharp	1 Dirt on external surfaces of the unit lens, eyepiece	1 Wipe clean external surfaces of lens (1) (Ref. Fig. 5.1) and eyepiece (2) with cloth (11) (Ref. Fig. 3.1) included in the single set of spare parts	Can be performed in the field
	2 Unit is out of focus (dioptric setting of eyepieces has not been performed, lenses have not been focused)	1 Adjust properly sharpness of image by rotating eyepiece (2) (Ref. Fig. 5.1) with the aid of adjustment ring (3). 2 Bring the image viewed in lenses (1) (Ref. Fig. 5.1) into sharp focus as instructed in Step 7.4	Can be performed in the field
3 Lens or eyepiece is affected by phy-	1 Forward the unit for repair		To be performed at a repair shop or

NVS 6 MANUAL

Trouble and symptoms	Probable cause	Remedy	Remarks
sical damage	repair		at Manufacturer's facilities
<p>3 One of the image-intensifier tube screens is not illuminated.</p> <p>Visible on the screen are black dots that tend to grow to a dimension of a segment</p>	<p>1 The image-intensifier tube is unserviceable</p>	<p>1 Forward the unit for repair</p>	<p>To be performed at a repair shop or at Manufacturer's facilities</p>
<p>4 With the unit energized, drops of moisture are visible on optical surfaces in the field of vision of the eyepiece</p>	<p>1 Moisture has got inside the unit (failure of the eyepiece sealing)</p>	<p>1 Replace dehydrator cartridge (13) (Ref. Fig. 5.1), by first inspecting the color of silica gel indicator through the sight glass (14). Replace silica gel</p>	<p>Can be performed in the field</p>

NVS 6 MANUAL

Trouble and symptoms	Probable cause	Remedy	Remarks
		when its color has changed to lilac or rosy	
5 Night-vision goggles are not properly secured on the mount of the helmet	1 Fixing assembly of the night-vision goggles is out of order	1 Forward the unit for repair	To be performed at a repair shop or at Manufacturer's facilities

NVS 6 MANUAL

10 MAINTENANCE PRACTICES

10.1 The maintenance operations to be carried out on the NVS 6 constitute the essential part of the unit operation and their correct performance can significantly prolong the unit service life and keep it always ready for use.

10.2 For maintaining the NVS 6 at constant readiness for service, provision is made for the following line maintenance procedures (preflight checks):

- (1) Preliminary preparation.
- (2) Preflight preparation.
- (3) Preparation for the next flight.
- (4) Post flight procedures.

10.3 The maintenance operations and checks stipulated by the above maintenance practices are presented in Table 5.

Table 5

Subject of maintenance and operations	Line maintenance procedures (preflight checks)			
	Preliminary preparation	Preflight preparation	Preparation for next flight	Post-flight procedures
1 Storage battery charging in accordance with the Manual furnished with the battery charging unit (in using rechargeable batteries) or replacement of batteries	+	-	-	-
2 Cleaning external surfaces of the lens and eyepiece in compliance with the procedure prescribed by this Manual	+	-	-	-

NVS 6 MANUAL

Table 5, cont'd

Subject of maintenance and operations	Line maintenance procedures (preflight checks)			
	Preliminary preparation	Preflight preparation	Preparation for next flight	Post-flight procedures
3 Inspection:				
Inspection of the night-vision goggles and their accessories for external condition as instructed in Section 8:	+	+	+	+
Checking the unit set for completeness	+	-	-	+
Checking the night-vision goggles and their accessories for external condition	+	+	+	+
Testing the night-vision goggles for serviceability	+	+	+	+
Checking the night-vision goggles for image quality	+	-	-	-
4 Preparation of the unit for use in compliance with Section 6:				
Individual adjustment and fitting of the unit	+	-	-	-
Arrangement of the night-vision goggles on the helicopter	-	+	-	-
5 Concluding operations on the unit as per Sections 6, 7	+	-	-	+

NVS 6 MANUAL

10.3.1 For cleaning the outer surfaces of the lenses and eyepieces, wipe them with a clean cloth included in the single set of spare parts, by first blowing off grains of sand and dust from the surfaces.

In case of severe contamination of the optical parts, do their cleaning as follows:

- Obtain a Q-tip (used for ears cleaning). If not available, wind a small amount of cotton wool around the end of a wooden stick, after having sharpened the stick end
- Moisten the cotton wool (or Q-tip) with alcohol or ether, or their mixture and then shake the stick to remove excess of liquid;
- Wipe the glass with the cotton wool (or Q-tip) several times without touching the eyepieces with hands
- Replace the cotton wool (or Q-tip) with a dry one and perform circular strokes with the cotton wool moving it from the center to the edge to finish the cleaning.

It should be remembered that the unit should be de-energized during the process of optical surfaces cleaning. Perform cleaning of the monocular pair, fixing assembly and unit accessories to remove dust, dirt, etc. (if any).

10.4 In the course of service and storage of the NVS 6, it is necessary to ensure replacement of the independent power source.

10.4.1 The rechargeable batteries shall be replaced on expiration of the guarantee period of their service life, whereas the batteries shall be replaced as they are run down.

10.5 The periodic maintenance checks (scheduled maintenance procedures) meant for maintaining the unit in the serviceable condition throughout the entire service life shall be conducted within the single time intervals as determined by the total flying time (Ref. Table 6).

Note – Information on the service time limits and man-hours to perform the maintenance checks is presented in the helicopter Manual.

NVS 6 MANUAL

Table 6

Procedure and parameter under check	Maintenance check intervals, hours (months)		
	50 (6 months)	100 (12 months)	200 (24 months)
1 Cleaning lens and eyepiece external surfaces	+	+	+
2 Inspection:			
Inspecting the night-vision goggles and their accessories for external condition	+	+	+
Checking the unit set for completeness	+	+	+
Testing the night-vision goggles and their accessories for serviceability	+	+	+
Checking the night-vision goggles for image quality (resolving power)	+	+	+
3 Periodic inspection:			
Checking screws for proper tightness and inadvertent loosening	+	+	+
Adjustment of retainers force for locking in operating position (if required)	+	+	+

NVS 6 MANUAL

10.6 The inspection procedure shall be performed as specified in Table 3.

10.7 The image quality shall be tested in compliance with Step 6.2.21.

10.8 The screws shall be checked for proper tightness, slipping and inadvertent loosening with the aid of the screwdriver, included in the set of spare parts.

When carrying out this check, make sure that the screws completely secure the joints between parts and assemblies. Screw slippage and loosening are inadvisable.

10.9 The adjustment of force of retainer (21) (Ref. Fig. 5.2) shall be accomplished by turning the retainer attachment screw.

When the screw is turned, the retaining force changes (retainer spring pressing force).

NVS 6 MANUAL

11 STORAGE AND SHIPMENT

11.1 The NVS 6 units should be stored in heated premises at a temperature of +5 to +40 °C and a relative air humidity of not in excess of 80 %.

11.2 Maintenance of the units, while at store, shall be performed as instructed in Section 10 of this Manual.

11.3 Perform preservation of the unit before placing it for prolonged storage. The preservation is done by the use of lamination method (the units are sealed in a polyethylene bags).

On the expiry of three years since preservation, the unit shall be subject to repeated preservation.

11.4 The NVS 6 can be shipped by any type of transport and over varied distances, provided proper packaging is in place.

During transportation the package that contains the case with the unit shall be securely protected against shocks and dropping.

The case shall be placed in the package with the top cover directed upwards and carefully fastened.

CAUTION: AVOID DROPPING THE PACKAGE WITH THE UNIT DURING LOADING AND UNLOADING OPERATIONS.

NVS 6 MANUAL

APPENDIX A

List of Illustrations

(reference)

Fig.	Title	Page
3.1	NVS 6 Standard Set	6
5.1	NVS 6	9
5.2	Night-Vision Goggles	11
5.3	Low-Voltage Converter	15
5.4	Mount	17
6.1	Replacement of Casing on Helmet	20
6.2	Assembly of Clamp with Retainer	21
6.3		21
6.4	Installation of Night-Vision Goggles on Helmet in Operating Position	24
6.5	Night-Vision Goggles Installed on Helmet in Stowed Position	25
6.6	Installation of Night-Vision Goggles on Helmet and Their Adjustment Relative to Pilot's Eyes	26
6.7	Connection of Night-Vision Goggles to Helicopter Electrical System Via Voltage Converter	27

APPENDIX B

List of Abbreviations

(reference)

FOV – Field of view

IPS – Independent power source

LVC – Low-voltage converter

NVS 6 MANUAL

WARRANTY:

NEWCON OPTIK warrants this product against defects in material and workmanship for one year from the date of the original date of consumer's purchase, but no more than 18 months from the date of manufacturing. Should your Newcon product prove defective during this period, please bring the product securely packaged in its original container or an equivalent, along with proof of the date of original purchase, to your Newcon Dealer. Newcon will, replace or repair (or at its option replace), the product or part thereof, which, on inspection by Newcon, is found to be defective in materials or workmanship.

*What This **Warranty Does Not Cover:***

NEWCON is not responsible for warranty service should the product fail to be properly maintained or fail to function properly as a result of misuse, abuse, improper installation, neglect, damage caused by disasters such as fire, flood, lightning, improper electrical current, or service other than by a NEWCON Authorized Service. Postage, insurance, or shipping costs incurred in presenting your NEWCON product for warranty service are your responsibility. Please include a cheque or money order made out to NEWCON OPTIK for the amount of \$15.00 to cover shipping and handling within Canada or the U.S.A. Shipping to other destinations will be done at the customer's expense.

8. Customer Support

Should you experience any difficulties with your Newcon OPTIK product, consult the enclosed manual. If the problem remains unresolved, contact our customer support department at (416) 663-6963 or Toll free at 1-877-398-6666. Our operating hours are 9am-5pm, Monday - Friday, standard East time. At no time should equipment be sent back to Newcon without following the instructions of our technical support department.

Newcon accepts no responsibility for unauthorized returns.

To locate the NEWCON Authorized Dealer call:

Tel: (416) 663-6963 Fax: (416) 663-9065

Email: NEWCONSALES@NEWCON-OPTIK.COM

INTERNET: <http://WWW.NEWCON-OPTIK.COM>

The defective products should be shipped to:

In USA: 3310 Prospect Ave. Cleveland, OH 44115

From other countries : 1183 Finch Ave. W., Suite 302, Toronto, ON M3J 2G2

NVS 6 MANUAL

Free Manuals Download Website

<http://myh66.com>

<http://usermanuals.us>

<http://www.somanuals.com>

<http://www.4manuals.cc>

<http://www.manual-lib.com>

<http://www.404manual.com>

<http://www.luxmanual.com>

<http://aubethermostatmanual.com>

Golf course search by state

<http://golfingnear.com>

Email search by domain

<http://emailbydomain.com>

Auto manuals search

<http://auto.somanuals.com>

TV manuals search

<http://tv.somanuals.com>