

OPERATOR'S MANUAL

10 in. (254 mm)

COMPOUND MITER SAW

WITH EXACTLINE™ LASER

MS1065LZ - Double Insulated

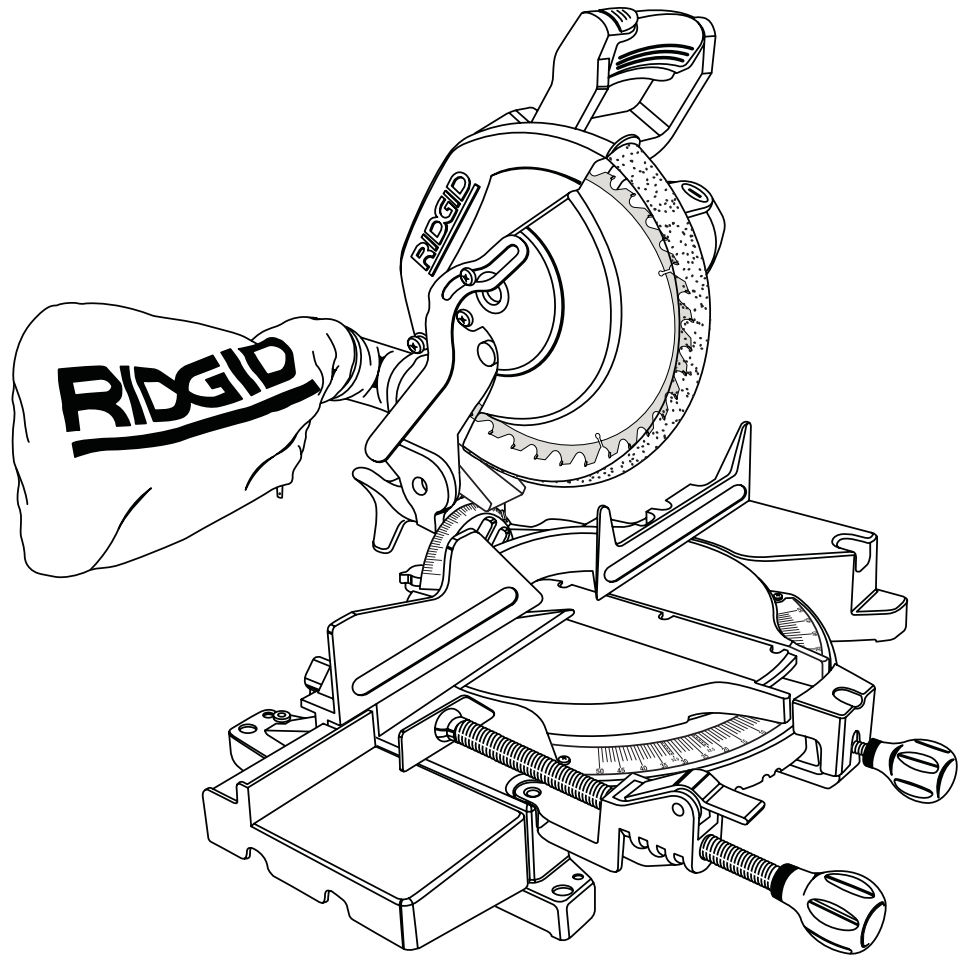

Your miter saw has been engineered and manufactured to our high standards for dependability, ease of operation, and operator safety. When properly cared for, it will give you years of rugged, trouble-free performance.

⚠ WARNING:

To reduce the risk of injury, the user must read and understand the operator's manual before using this product.

Thank you for buying a Ridgid product.

SAVE THIS MANUAL FOR FUTURE REFERENCE

TABLE OF CONTENTS

| | |
|---|-------|
| ■ Introduction | 2 |
| ■ Symbols | 3 |
| ■ Rules for Safe Operation | 4-6 |
| ■ Glossary of Terms | 6 |
| ■ Product Specifications and Electrical | 7 |
| ■ Unpacking and Tools Needed | 8 |
| ■ Loose Parts | 9 |
| ■ Features | 10-12 |
| ■ Assembly | 13-15 |
| ■ Adjustments | 15-18 |
| ■ Operation | 18-25 |
| ■ Laser Guide | 26-27 |
| ■ Maintenance | 28 |
| ■ Warranty | 29 |
| ■ Parts Ordering/Service | 30 |

INTRODUCTION

Your saw has many features for making the use of this product more pleasant and enjoyable. Safety, performance, and dependability have been given top priority in the design of this product making it easy to maintain and operate.

WARNING:

Do not attempt to use this product until you thoroughly read and completely understand the operator's manual. Pay close attention to the safety rules, including Dangers, Warnings, and Cautions. If you use your product properly and only as intended, you will enjoy years of safe, reliable service.

IMPORTANT

Servicing of a tool with double insulation requires extreme care and knowledge of the system and should be performed only by a qualified service technician. For service we suggest you return the tool to your nearest **AUTHORIZED SERVICE CENTER** for repair. When servicing use only identical replacement parts.

WARNING:

Do not attempt to use this product until you read thoroughly and understand completely the operator's manual. Pay close attention to the safety rules, including Dangers, Warnings, and Cautions. If you use your product properly and only as intended, you will enjoy years of safe, reliable service.



Look for this symbol to point out important safety precautions. It means attention!!! Your safety is involved.



The operation of any tool can result in foreign objects being thrown into your eyes, which can result in severe eye damage. Before beginning operation, always wear safety goggles or safety glasses with side shields and a full face shield when needed. We recommend Wide Vision Safety Mask for use over eyeglasses or standard safety glasses with side shields. Always wear eye protection which is marked to comply with ANSI Z87.1.

RULES FOR SAFE OPERATION

The purpose of safety symbols is to attract your attention to possible dangers. The safety symbols, and the explanations with them, deserve your careful attention and understanding. The safety warnings do not by themselves eliminate any danger. The instructions or warnings they give are not substitutes for proper accident prevention measures.

SYMBOL MEANING



DANGER: Indicates an imminently hazardous situation, which, if not avoided, will result in death or serious injury.



WARNING: Indicates a potentially hazardous situation, which, if not avoided, could result in death or serious injury.



CAUTION: Indicates a potentially hazardous situation, which, if not avoided, may result in minor or moderate injury. It may also be used to alert against unsafe practices that may cause property damage.

Important: Advises you of important information or instructions vital to the operation or maintenance of the equipment.

Note: Advises you of additional information concerning the operation or maintenance of the equipment.

SAFETY AND INTERNATIONAL SYMBOLS

This operator's manual describes safety and international symbols and pictographs that may appear on this product. Read the operator's manual for complete safety, assembly, operating and maintenance, and repair information.

SYMBOL



MEANING

- Do not expose to rain or use in damp locations.



NO HANDS SYMBOL

- Failure to keep your hands away from the blade will result in serious personal injury.

Safe operation of this power tool requires that you read and understand this operator's manual and all labels affixed to the tool. Safety is a combination of common sense, staying alert, and knowing how your miter saw works.

READ ALL INSTRUCTIONS

- **KNOW YOUR POWER TOOL.** Read the operator's manual carefully. Learn the saw's applications and limitations as well as the specific potential hazards related to this tool.
- **GUARD AGAINST ELECTRICAL SHOCK** by preventing body contact with grounded surfaces such as pipes, radiators, ranges, refrigerator enclosures.
- **KEEP GUARDS IN PLACE** and in good working order.
- **REMOVE WRENCHES AND ADJUSTING KEYS.** Get in the habit - before turning on tool - that hex keys and adjusting wrenches are removed from tool.

- **KEEP THE WORK AREA CLEAN.** Cluttered work areas and work benches invite accidents. **DO NOT** leave tools or pieces of wood on the saw while it is in operation.
- **DO NOT USE IN DANGEROUS ENVIRONMENTS.** Do not use power tools near gasoline or other flammable liquids, in damp or wet locations, or expose them to rain. Keep the work area well lit.
- **KEEP CHILDREN AND VISITORS AWAY.** All visitors should wear safety glasses and be kept a safe distance from work area. Do not let visitors contact tool or extension cord while operating.
- **MAKE WORKSHOP CHILDPROOF** with padlocks and master switches or by removing starter keys.
- **DO NOT FORCE THE TOOL** it will do the job better and safer at the rate for which it was designed.

RULES FOR SAFE OPERATION

- **USE THE RIGHT TOOL FOR THE JOB.** Do not force the tool or attachment to do a job it was not designed for. Use it only the way it was intended.
- **USE THE PROPER EXTENSION CORD.** Make sure your extension cord is in good condition. Use only a cord heavy enough to carry the current your product will draw. An undersized cord will cause a drop in line voltage resulting in loss of power and overheating. A wire gage size (A.W.G.) of at least **14** is recommended for an extension cord 25 feet or less in length. If in doubt, use the next heavier gage. The smaller the gage number, the heavier the cord.
- **INSPECT TOOL CORDS AND EXTENSION CORDS PERIODICALLY** and, if damaged, have repaired at your nearest authorized service center. Stay constantly aware of cord location and keep it well away from the moving blade.
- **DRESS PROPERLY.** Do not wear loose clothing, gloves, neckties, rings, bracelets, or other jewelry that can get caught and draw you into moving parts. Nonslip footwear is recommended. Also wear protective hair covering to contain long hair when used on another tool.
- **ALWAYS WEAR SAFETY GLASSES WITH SIDE SHIELDS.** Everyday eyeglasses have only impact-resistant lenses; they are **NOT** safety glasses.
- **WEAR A DUST MASK** to keep from inhaling fine particles.
- **PROTECT YOUR HEARING.** Wear hearing protection during extended periods of operation.
- **SECURE WORK.** Use clamps or a vise to hold work when practical. It's safer than using your hand and frees both hands to operate tool.
- **DO NOT OVERREACH.** Keep proper footing and balance at all times.
- **MAINTAIN TOOLS WITH CARE.** Keep tools sharp and clean for better and safer performance. Follow instructions for lubricating and changing accessories.
- **DISCONNECT ALL TOOLS.** When not in use, before servicing, or when changing attachments, all tools should be disconnected.
- **AVOID ACCIDENTAL STARTING.** Be sure switch is off when plugging in any tool.
- **USE RECOMMENDED ACCESSORIES.** Consult the operator's manual for recommended accessories. The use of improper accessories may case risk of injury.
- **NEVER STAND ON TOOL.** Serious injury could occur if the tool is tipped or if the blade is unintentionally contacted.
- **CHECK DAMAGED PARTS.** Before using the tool, a guard or other part that is damaged should be carefully checked to determine that it will operate properly and perform its intended function. Check for alignment of moving parts, binding of moving parts, breakage of parts, mounting and any other conditions that may affect its operation. A guard or other part that is damaged must be properly repaired or replaced by an authorized service center to avoid risk of personal injury.
- **NEVER LEAVE TOOL RUNNING UNATTENDED, TURN THE POWER OFF.** Do not leave tool until it comes to a complete stop.
- **FIRMLY CLAMP OR BOLT** your miter saw to a workbench or table at approximately hip height.
- **USE ONLY CORRECT BLADES.** Use the right blade size, style and cutting speed for material and type of cut. Do not use blades with incorrect size holes. Never use blade washers or blade bolts that are defective or incorrect. The maximum blade capacity of your saw is 10 in.
- **KEEP BLADES CLEAN, SHARP, AND WITH SUFFICIENT SET.** Sharp blades minimize stalling and kickback.
- **DO NOT REMOVE THE SAW'S BLADE GUARDS.** Never operate the saw with any guard or cover removed. Make sure all guards are operating properly before each use.
- **KEEP HANDS AWAY FROM CUTTING AREA.** Do not reach underneath work or in blade cutting path with hands and fingers for any reason. Always turn power off.
- **BLADE COASTS AFTER BEING TURNED OFF.**
- **DO NOT ABUSE CORD.** Never yank cord to disconnect it from receptacle. Keep cord from heat, oil, and sharp edges.
- **USE ONLY OUTDOOR EXTENSION CORDS.** Use only extension cords with the marking "Acceptable for use with outdoor appliances; store cords indoors while not in use". Use extension cords with an electrical rating not less than the saw's rating. Always disconnect the extension cord from the outlet before disconnecting the product from the extension cord.
- **DO NOT USE TOOL IF SWITCH DOES NOT TURN IT ON AND OFF.** Have defective switches replaced by an authorized service center.
- **KEEP TOOL DRY, CLEAN, AND FREE FROM OIL AND GREASE.** Always use a clean cloth when cleaning. Never use brake fluids, gasoline, petroleum-based products, or any solvents to clean tool.
- **ALWAYS SUPPORT LONG WORKPIECES** while cutting to minimize risk of blade pinching and kickback. Saw may slip, walk or slide while cutting long or heavy boards.
- **BEFORE MAKING A CUT,** be sure all adjustments are secure.

RULES FOR SAFE OPERATION

- **BE SURE BLADE PATH IS FREE OF NAILS.** Inspect for and remove all nails from lumber before cutting.
- **NEVER TOUCH BLADE** or other moving parts during use for any reason.
- **BE SURE THE BLADE CLEARS THE WORKPIECE.** Never start the saw with the blade touching the workpiece. Allow motor to come up to full speed before starting cut.
- **MAKE SURE MITER TABLE AND SAW ARM (BEVEL FUNCTION) ARE LOCKED IN POSITION BEFORE OPERATING YOUR SAW.** Lock the miter table by securely tightening the miter lock handle. Lock the saw arm (bevel function) by securely tightening the bevel lock knob.
- **NEVER USE A LENGTH STOP ON THE FREE SCRAP END OF A CLAMPED WORKPIECE. NEVER** hold onto or bind the free scrap end of the workpiece in any operation. If a work clamp and length stop are used together, they must both be installed on the same side of the saw table to prevent the saw from catching the loose end and kicking up.
- **NEVER** cut more than one piece at a time. **DO NOT STACK** more than one workpiece on the saw table at a time.
- **NEVER PERFORM ANY OPERATION FREEHAND.** Always place the workpiece to be cut on the miter table and position it firmly against the fence as a backstop. Always use the fence.
- **NEVER** reach behind, under, or within three inches of the blade and its cutting path with your hands and fingers for any reason.
- **NEVER** hand hold a workpiece that is too small to be clamped. Keep hands clear of the no hands zone.
- **NEVER** reach to pick up a workpiece, a piece of scrap, or anything else that is in or near the cutting path of the blade.
- **AVOID AWKWARD OPERATIONS AND HAND POSITIONS** where a sudden slip could cause your hand to move into the blade. **ALWAYS** make sure you have good balance. **NEVER** operate your miter saw on the floor or in a crouched position.
- **NEVER** stand or have any part of your body in line with the path of the saw blade.
- **ALWAYS** release the power switch and allow the saw blade to stop rotating before raising it out of the workpiece.
- **DO NOT TURN THE MOTOR SWITCH ON AND OFF RAPIDLY.** This could cause the saw blade to loosen and could create a hazard. Should this ever occur, stand clear and allow the saw blade to come to a complete stop. Disconnect your saw from the power supply and securely retighten the blade bolt.
- **REPLACEMENT PARTS.** All repairs, whether electrical or mechanical, should be made at your nearest authorized service center.
- **WHEN SERVICING,** use only identical replacement parts. Use of any other parts may create a hazard or cause product damage.
- **NEVER USE THIS TOOL IN AN EXPLOSIVE ATMOSPHERE.** Normal sparking of the motor could ignite fumes.
- **POLARIZED PLUGS.** To reduce the risk of electric shock, this tool has a polarized plug (one blade is wider than the other). This plug will fit in a polarized outlet only one way. If the plug does not fit fully in the outlet, reverse the plug. If it still does not fit, contact a qualified electrician to install the proper outlet. Do not change the plug in any way.
- **IF ANY PART OF THIS MITER SAW IS MISSING** or should break, bend, or fail in any way, or should any electrical component fail to perform properly, shut off the power switch, remove the miter saw plug from the power source and have damaged, missing, or failed parts replaced before resuming operation.
- **DO NOT OPERATE THIS TOOL WHILE UNDER THE INFLUENCE OF DRUGS, ALCOHOL, OR ANY MEDICATION.**
- **ALWAYS STAY ALERT!** Do not allow familiarity (gained from frequent use of your saw) to cause a careless mistake. **ALWAYS REMEMBER** that a careless fraction on a second is sufficient to inflict serious injury.
- **STAY ALERT AND EXERCISE CONTROL.** Watch what you are doing and use common sense. **Do not operate tool when you are tired. Do not rush.**
- **MAKE SURE THE WORK AREA HAS AMPLE LIGHTING** to see the work and that no obstructions will interfere with safe operation **BEFORE** performing any work using your saw.
- **ALWAYS TURN OFF THE SAW** before disconnecting it to avoid accidental starting when reconnecting to power supply. **NEVER** leave the saw unattended while connected to a power source.
- **TURN OFF TOOL** and wait for saw blade to come to a complete stop before moving workpiece or changing settings.

RULES FOR SAFE OPERATION

- **THIS TOOL** shall have the following markings:
 - a) Wear eye protection.
 - b) Keep hands out of path of saw blade.
 - c) Do not operate saw without guards in place.
 - d) Do not perform any operation freehand.
 - e) Never reach around saw blade.
 - f) Turn off tool and wait for saw blade to stop before moving workpiece or changing settings.
 - g) Disconnect power (or unplug tool as applicable) before changing blade or servicing.
 - h) No load speed.
- **ALWAYS** carry the saw only by the carrying handle.
- **AVOID** direct eye exposure when using the laser guide.
- **SAVE THESE INSTRUCTIONS.** Refer to them frequently and use them to instruct other users. If you loan someone this tool, loan them these instructions also.

WARNING:

Some dust created by power sanding, sawing, grinding, drilling, and other construction activities contains chemicals known to cause cancer, birth defects or other reproductive harm. Some examples of these chemicals are:

- lead from lead-based paints,
- crystalline silica from bricks and cement and other masonry products, and
- arsenic and chromium from chemically-treated lumber.

Your risk from these exposures varies, depending on how often you do this type of work. To reduce your exposure to these chemicals, work in a well ventilated area and work with approved safety equipment, such as those dust masks that are specially designed to filter out microscopic particles.

GLOSSARY OF TERMS FOR WOODWORKING

Arbor

The shaft on which a blade or cutting tool is mounted.

Bevel Cut

A cutting operation made with the blade at any angle other than 90° to the miter table.

Compound Miter Cut

A compound miter cut is a cut made using a miter angle and a bevel angle at the same time.

Crosscut

A cutting or shaping operation made across the grain of the workpiece.

Freehand

Performing a cut without using a fence, vise, fixture, work clamp, or other proper device to keep the workpiece from twisting or moving during the cut.

Gum

A sticky, sap based residue from wood products.

Miter Cut

A cutting operation made with the blade at any angle other than 90° to the fence.

No Hands Zone

Area between the marked lines on the left and right side of the miter table base. This zone is identified by no hands zone labels placed inside the marked lines on the miter table base.

Resin

A sticky, sap base substance that has hardened.

Revolutions Per Minute (RPM)

The number of turns completed by a spinning object in one minute.

Saw Blade Path

The area over, under, behind, or in front of the blade. As it applies to the workpiece, that area which will be, or has been, cut by the blade.

Set

The distance that the tip of the saw blade tooth is bent (or set) outward from the face of the blade.

Through Sawing

Any cutting operation where the blade extends completely through the thickness of the workpiece.

Throw-Back

Throwing of a workpiece in a manner similar to a kickback. Usually associated with a cause other than the kerf closing, such as a workpiece not being against the fence, being dropped into the blade, or being placed inadvertently in contact with the blade.

Workpiece

The item on which the cutting operation is being done. The surfaces of a workpiece are commonly referred to as faces, ends, and edges.

Zero Clearance Throat Plate

A plastic throat plate inserted in the miter table that allows for blade clearance. When you make your first cut with your compound miter saw, the saw blade cuts a slot through the throat plate the exact width of the blade. This provides for a zero clearance kerf that minimizes workpiece tear-out.

SPECIFICATIONS

| | |
|----------------------|--------------------------------------|
| Blade Arbor | 5/8 in. (16 mm) |
| Blade Diameter | 10 in. (254 mm) |
| Input | 120 volts, 60Hz, AC Only, 15 Amperes |
| No Load Speed | 5000 RPM |
| Net Weight | 34 lbs. (15.4 kg.) |

ELECTRICAL

DOUBLE INSULATION

Double insulation is a concept in safety in electric power tools, which eliminates the need for the usual three-wire grounded power cord. All exposed metal parts are isolated from the internal metal motor components with protecting insulation. Double insulated tools do not need to be grounded.

WARNING:

The double insulated system is intended to protect the user from shock resulting from a break in the tool's internal wiring. Observe all normal safety precautions to avoid electrical shock.

Important: Servicing of a tool with double insulation requires extreme care and knowledge of the system and should be performed only by a qualified service technician. For service, we suggest you return the tool to your nearest authorized service center for repair. Always use original factory replacement parts when servicing.

ELECTRICAL CONNECTION

Your saw has a precision built electric motor. It should be connected to a **power supply that is 120 volts, 60Hz, AC only (normal household current)**. Do not operate this tool on direct current (DC). A substantial voltage drop will cause a loss of power and the motor will overheat. If your tool does not operate when plugged into an outlet, double-check the power supply.

EXTENSION CORDS

When using a power tool at a considerable distance from a power source, be sure to use an extension cord that has the capacity to handle the current the tool will draw. An undersized cord will cause a drop in line voltage, resulting in overheating and loss of power. Use the chart to determine the minimum wire size required in an extension cord. Only round jacketed cords listed by Underwriter's Laboratories (UL) should be used.

When working outdoors with a tool, use an extension cord that is designed for outside use. This type of cord is designated with "WA" on the cord's jacket.

Before using any extension cord, inspect it for loose or exposed wires and cut or worn insulation.

**Ampere rating
(on tool faceplate)

| | | | | | |
|-------|---------|---------|---------|----------|-----------|
| 0-2.0 | 2.1-3.4 | 3.5-5.0 | 5.1-7.0 | 7.1-12.0 | 12.1-16.0 |
|-------|---------|---------|---------|----------|-----------|

| Cord Length | Wire Size (A.W.G.) | | | | | |
|-------------|--------------------|----|----|----|----|----|
| 25' | 16 | 16 | 16 | 16 | 14 | 14 |
| 50' | 16 | 16 | 16 | 14 | 14 | 12 |
| 100' | 16 | 16 | 14 | 12 | 10 | — |

**Used on 12 gauge - 20 amp circuit.

CAUTION:

Keep the extension cord clear of the working area. Position the cord so that it will not get caught on lumber, tools or other obstructions while you are working with a power tool.

WARNING:

Check extension cords before each use. If damaged replace immediately. Never use tool with a damaged cord since touching the damaged area could cause electrical shock resulting in serious injury.

UNPACKING

Your Compound Miter Saw has been shipped completely assembled except for the blade, miter lock handle, dust guide or dust bag, laser guide, and work clamp.

- Remove all loose parts from the carton. Separate and check with the list of loose parts. *See Figure 1.*
- Remove the packing materials from around your saw.
- Carefully lift saw from the carton by the carrying handle and place it on a level work surface. Although small, this saw is heavy. To avoid back injury, get help when needed.
- Do not discard the packing materials until you have carefully inspected the saw, identified all loose parts, and satisfactorily operated your new saw.

- Examine all parts to make sure no breakage or damage has occurred during shipping.
- If any parts are damaged or missing, please call 1-866-539-1710 for assistance.

⚠ WARNING:

If any parts are missing, do not operate this tool until the missing parts are replaced. Failure to do so could result in possible serious personal injury.

TOOLS NEEDED

The following tools (not included) are needed for checking adjustments of your saw or for installing the blade:



12 mm COMBINATION WRENCH

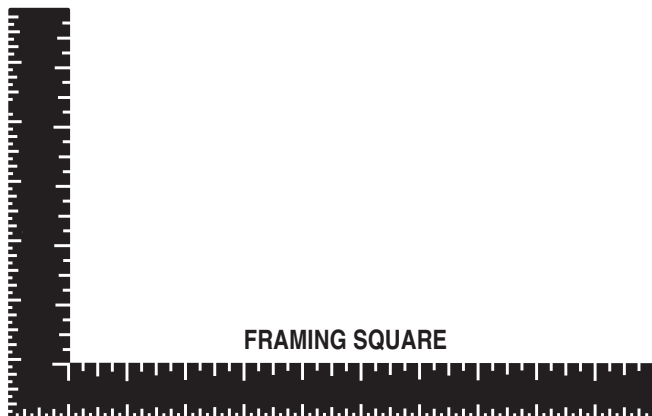

FRAMING SQUARE

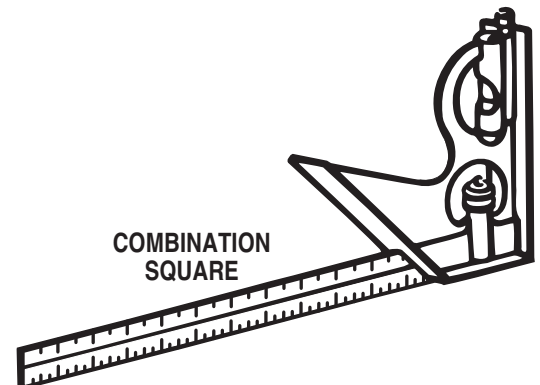

COMBINATION SQUARE

LOOSE PARTS LIST

The following items are included with your Compound Miter Saw:

- 10 in. (254 mm) Saw Blade
- Miter Lock Handle
- Dust Bag
- Dust Guide
- Work Clamp
- 6 mm Hex Key
- 8 mm Hex Key
- Table Extension
- Socket Head Screw (2)
- Washer (2)
- Blade Wrench
- Exactline™ Laser
- Hex Bolt
- Operator's Manual
- Warranty Registration Card

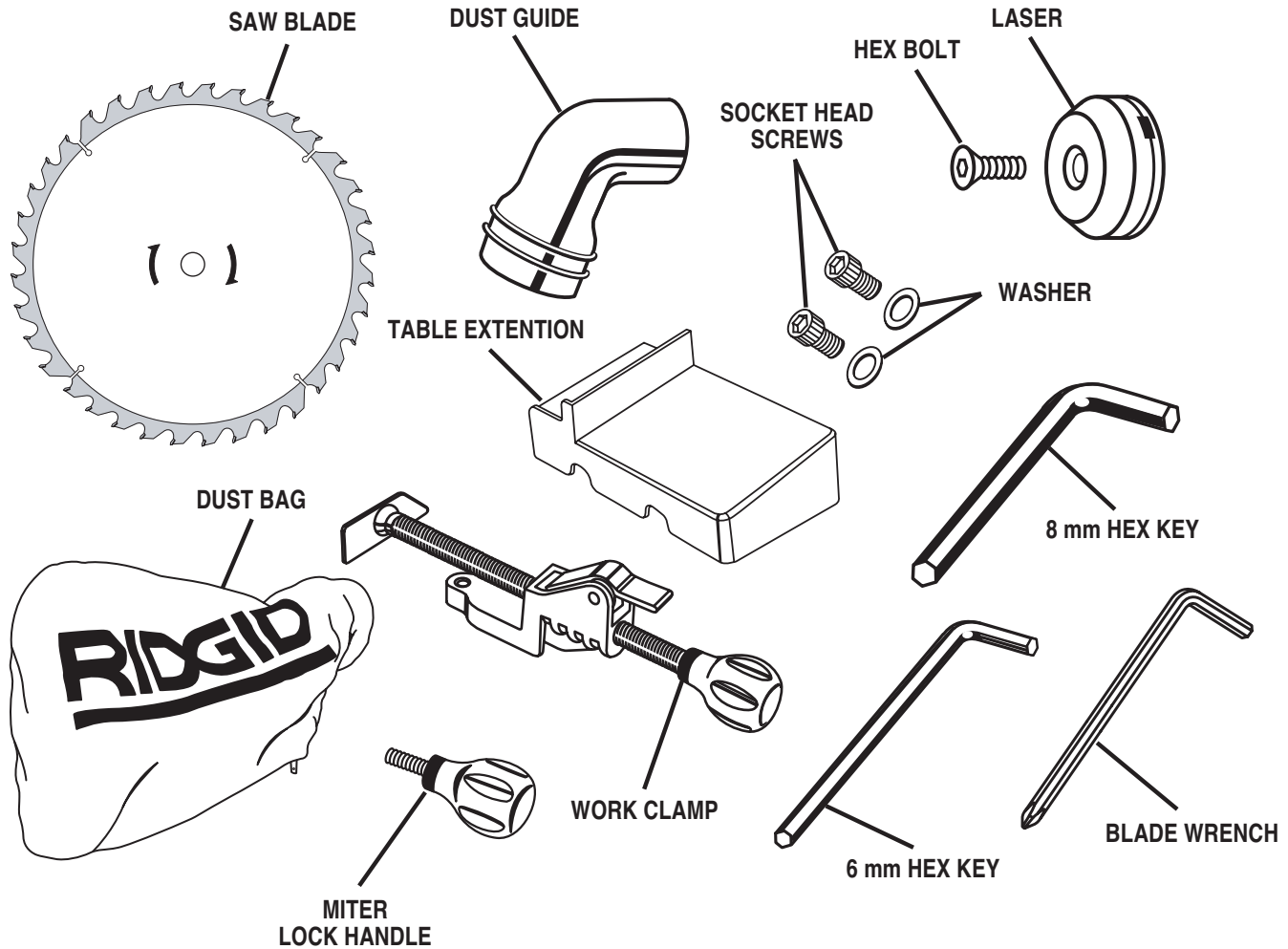

Fig. 1

⚠ WARNING:

The use of attachments or accessories not listed might be hazardous and could cause serious personal injury.

FEATURES

KNOW YOUR COMPOUND MITER SAW

See Figure 2.

Before using this product, familiarize yourself with all operating features and safety requirements. However, do not let familiarity with the tool make you careless.

⚠ WARNING:

Exercise caution when using this tool. Careless actions, for even a fraction of a second, can result in serious personal injury.

15 AMP MOTOR

Your saw has a powerful 15 amp motor with sufficient power to handle tough cutting jobs. It is made with all ball bearings.

10 IN. BLADE

A 10 in. (254 mm) saw blade is included with your compound miter saw. It is fine for most wood cutting operations, but for fine joinery cuts or cutting plastic, use one of the accessory blades available from your nearest dealer.

CUTTING CAPACITIES

When the miter angle (miter table) is set at 0°:

Maximum dimensional lumber sizes: 4 x 4
2 x 6

When the miter angle (miter table) is set at 45°:

Maximum dimensional lumber size: 2 x 4

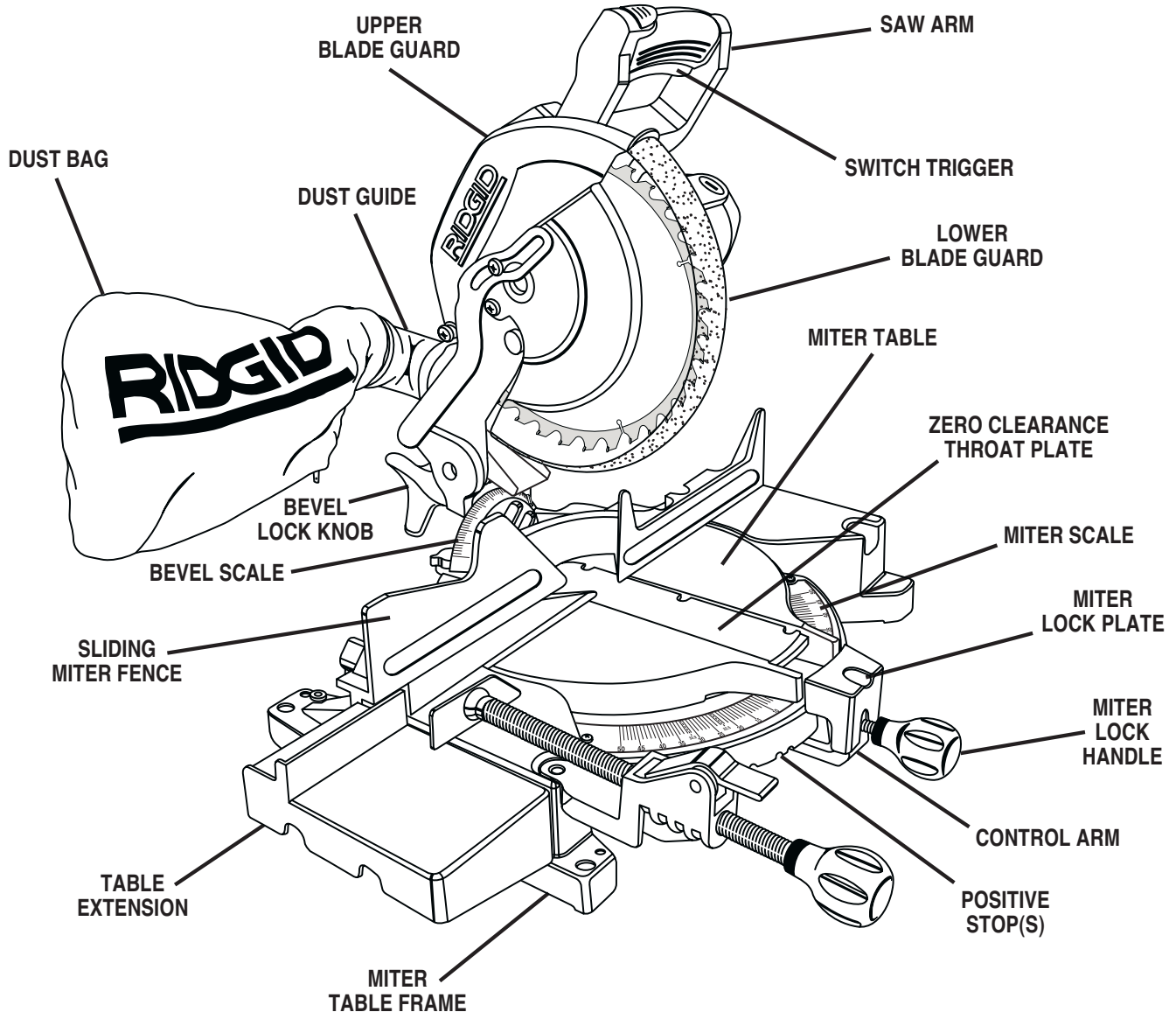

Fig. 2

FEATURES

BLADE WRENCH / STORAGE AREA

See Figure 2.

A blade wrench is packed with your saw. One end of the wrench is a phillips screwdriver and the other end is a 5 mm hex key. Use the hex key end when installing or removing blade and the phillips end when removing or loosening screws. A storage area for the blade wrench is located behind the fence.

CARRYING HANDLE

See Figure 3.

For convenience when carrying or transporting your miter saw from one place to another, a carrying handle has been provided on top of the saw arm as shown in figure 3. To transport, turn off and unplug your saw, then lower the saw arm and lock it in the down position. Lock saw arm by depressing the lock pin.

MITER LOCK HANDLE

See Figure 3.

The miter lock handle securely locks your saw at desired miter angles.

SPINDLE LOCK BUTTON

See Figure 4.

A spindle lock button has been provided for locking the spindle which keeps the blade in your saw from rotating. Depress and hold the lock button while installing, changing, or removing blade only.

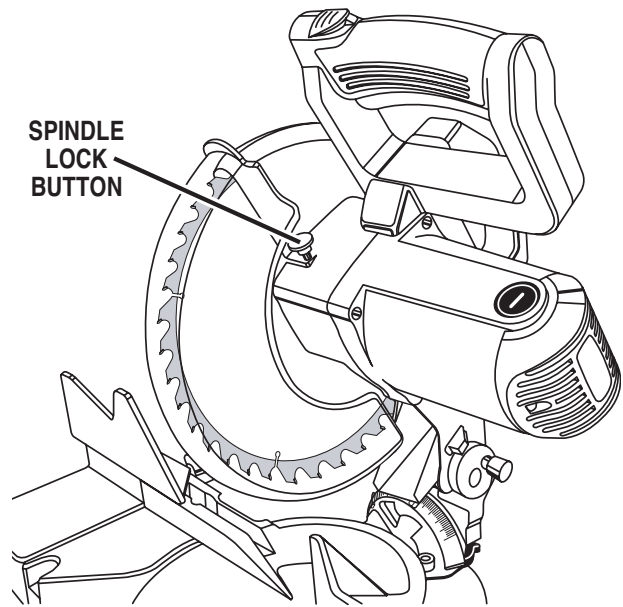

Fig. 4

PADLOCK

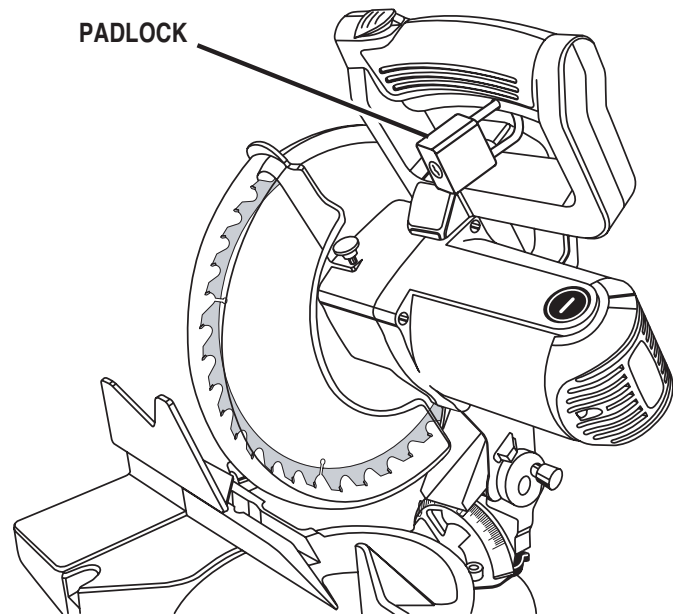

Fig. 5

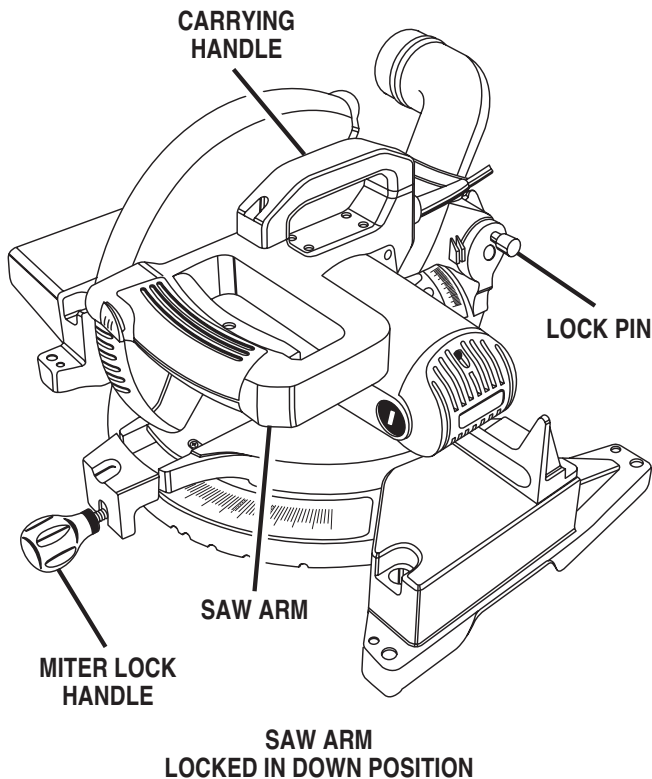

Fig. 3

TRIGGER LOCK

See Figure 5.

To prevent unauthorized use of your compound miter saw, we suggest that you disconnect it from the power supply and lock the switch in the off position. To lock the switch, install a padlock (not included) through the hole in the switch trigger. A lock with a long shackle up to 9/32 in. (7 mm) diameter may be used. When the lock is installed and locked, the switch is inoperable. Store the padlock key in another location.

FEATURES

POSITIVE STOPS ON MITER TABLE

Positive stops have been provided at 0°, 11.25°, 15°, 22.5°, 31.62°, and 45°. The 0°, 11.25°, 15°, 22.5°, 31.62°, and 45° positive stops have been provided on both the left and right side of the miter table.

BEVEL LOCK KNOB

The bevel lock knob securely locks your compound miter saw at desired bevel angles. Positive stop adjustment screws have been provided on each side of the saw arm. These adjustment screws are for making fine adjustments at 0° and 45°. Using the bevel override feature allows up to 48° for bevel cuts.

ELECTRIC BRAKE

An electric brake has been provided to quickly stop blade rotation after the switch is released.

MITER FENCE

The miter fence on your compound miter saw has been provided to hold your workpiece securely against when making all cuts. The sliding miter fence on the left side is also larger providing additional support.

The Repeat-A-Cut™ feature on both the left and right side miter fences can be used when making repetitive cuts. Simply mark the fence with a pencil, make the desired number of cut(s), then wipe the mark off with a soft cloth.

SELF-RETRACTING LOWER BLADE GUARD

The lower blade guard is made of shock-resistant, see-through plastic that provides protection from each side of the blade. It retracts over the upper blade guard as the saw is lowered into the workpiece.

⚠ WARNING:

To avoid serious personal injury, always assure saw is fully supported and securely attached to a level work surface.

MOUNTING HOLES

See Figure 6.

Your compound miter saw should be mounted to a firm supporting surface such as a workbench. Four bolt holes have been provided in the saw base for this purpose. Each of the four mounting holes should be bolted securely using 3/8 in. (10 mm) machine bolts, lock washers, and hex nuts (not included). Bolts should be of sufficient length to accommodate the saw base, lock washers, hex nuts, and the thickness of the workbench. Tighten all four bolts securely.

The hole pattern is for an 18 in. x 24 in. (457 mm x 610 mm) workbench. Carefully check the workbench after mounting to make sure that no movement can occur during use. If any tipping, sliding, or walking is noted, secure the workbench to the floor before operating.

⚠ WARNING:

The operation of any saw can result in foreign objects being thrown into your eyes, which can result in severe eye damage. Before starting power tool operation, always wear safety goggles or safety glasses with side shields and a full face shield when needed. We recommend wide vision safety mask for use over eyeglasses or standard safety glasses with side shields.

⚠ WARNING:

Do not attempt to modify this tool or create accessories not recommended for use with this tool. Any such alteration or modification is misuse and could result in a hazardous condition leading to possible serious personal injury.

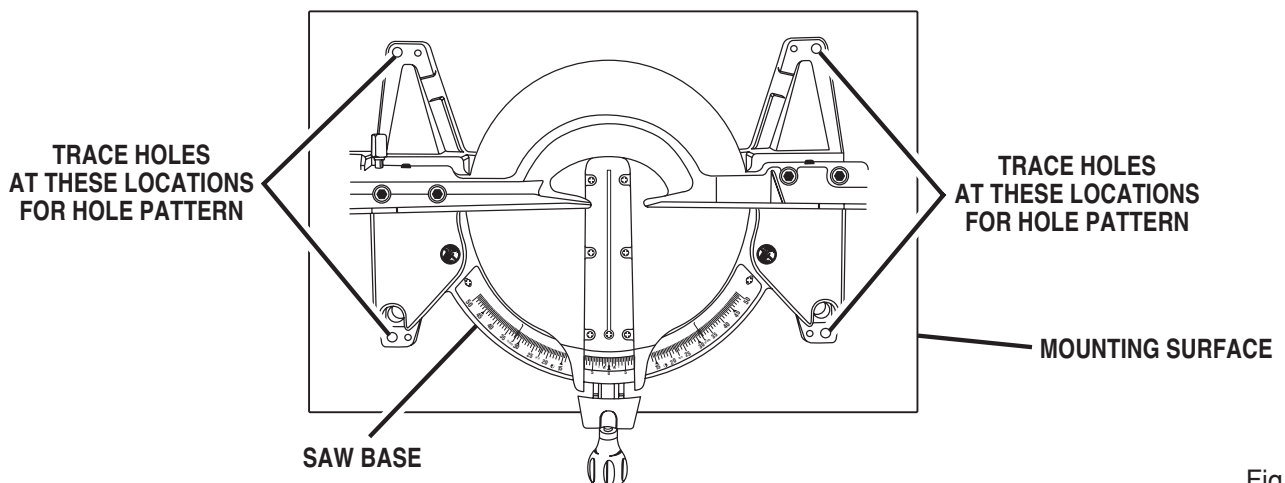

Fig. 6

ASSEMBLY

⚠ WARNING:

To prevent accidental starting that could cause possible serious personal injury, assemble all parts, make sure all adjustments are complete, and make sure all fasteners are secure before connecting saw to power supply. Saw should never be connected to power supply when you are assembling parts, making adjustments, installing or removing blades, or when not in use.

MITER LOCK HANDLE

See Figure 7.

To install the miter lock handle, place the threaded stud on the end of the miter lock handle into the threaded hole in the control arm under miter table. Turn clockwise to tighten.

DUST GUIDE

See Figure 8.

Insert the dust guide inside the exhaust port in the upper blade guard. Turn the guide so that the open end is facing down.

DUST BAG

See Figure 9.

A dust bag is provided for use on your miter saw. It fits over the exhaust port on the upper blade guard. To install it, remove dust guide from exhaust port. Then, squeeze the two metal clips to open the mouth of the bag and slide it on the exhaust port. Release the clips. The metal ring in the bag should lock in between the grooves on the exhaust port. To remove the dust bag for emptying, simply reverse the above procedure.

WORK CLAMP

See Figure 10.

The work clamp provides greater control by clamping the workpiece to the fence or the saw table. It also prevents the workpiece from creeping toward the saw blade. This is very helpful when cutting compound miters.

Depending on the cutting operation and the size of the workpiece, it may be necessary to use a C-clamp instead of the work clamp to secure the workpiece prior to making the cut.

⚠ WARNING:

In some operations, the work clamp assembly may interfere with the operation of the blade guard assembly. Always make sure there is no interference with the blade guard prior to beginning any cutting operation to reduce the risk of serious personal injury.

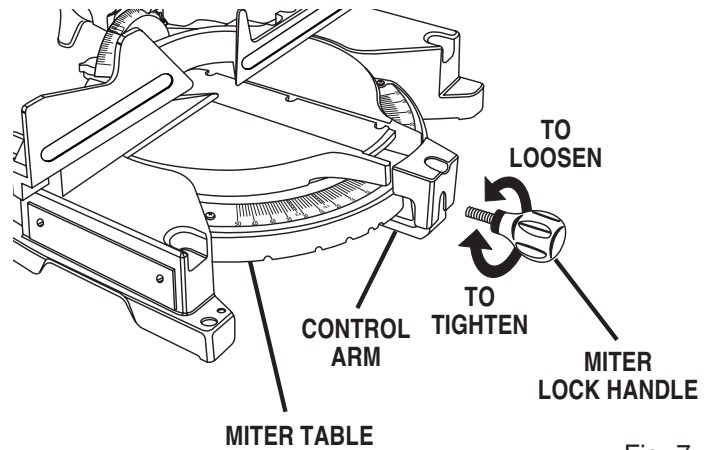

Fig. 7

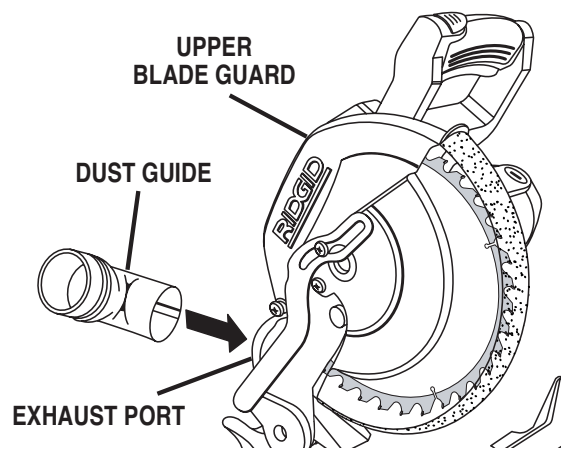

Fig. 8

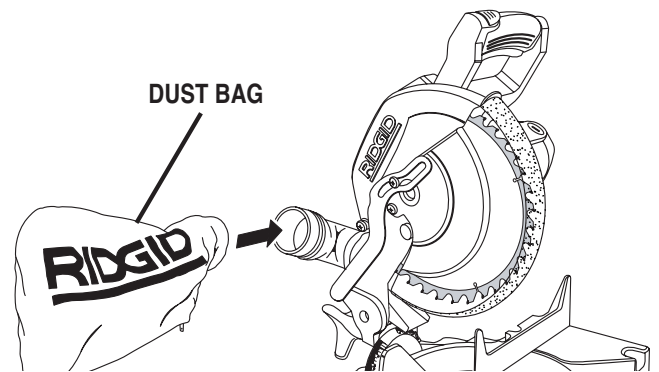

Fig. 9

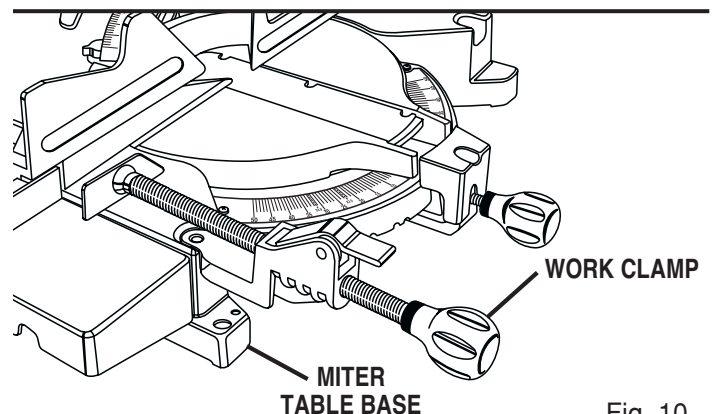

Fig. 10

ASSEMBLY

TABLE EXTENSION

See Figure 11.

The table extension can be used on the left side of your miter saw. To assemble and install the table extension:

- Insert socket head screw and washer into the two holes in the side of the miter saw base.
- Tighten securely.

TO INSTALL BLADE

See Figure 12.

⚠ WARNING:

A 10 in. (254 mm) blade is the maximum blade capacity of your saw. Never use a blade that is too thick to allow outer blade washer to engage with the flats on the spindle. Larger blades will come in contact with the blade guards, while thicker blades will prevent the blade bolt from securing the blade on the spindle. Either of these situations could result in a serious accident and can cause serious personal injury.

- Unplug your saw.

⚠ WARNING:

Failure to unplug your saw could result in accidental starting causing possible serious personal injury.

- Raise saw arm.
 - Rotate lower blade guard up and remove screw B. Rotate blade bolt cover up and back to expose the blade bolt.
 - Depress the spindle lock button and rotate the blade bolt until the spindle locks.
 - Using the wrench provided, loosen and remove the blade bolt. See Figure 12.
- Note:** The blade bolt has left hand threads. Turn blade bolt clockwise to loosen.
- Remove outer blade washer. **Do not** remove inner blade washer.
 - Wipe a drop of oil onto inner blade washer and outer blade washer where they contact the blade.

⚠ WARNING:

If inner blade washer has been removed, replace it before placing blade on spindle. Failure to do so could cause an accident since blade will not tighten properly.

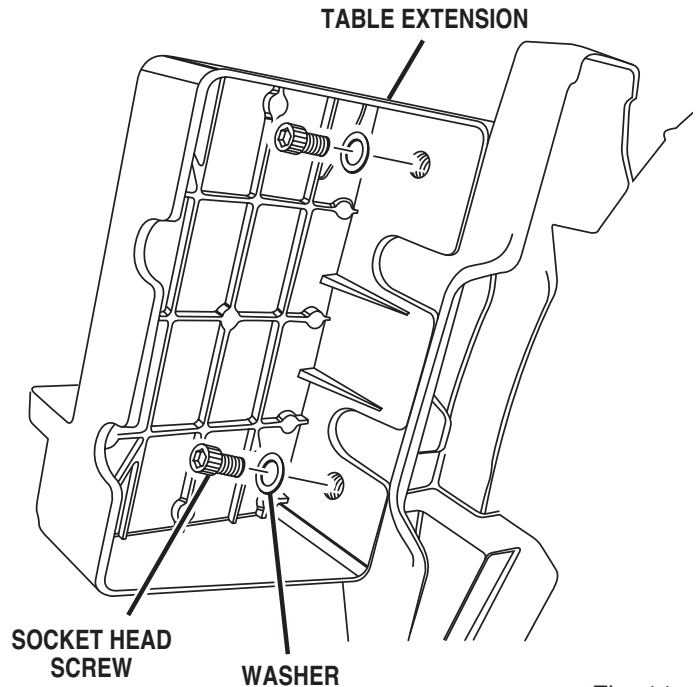

Fig. 11

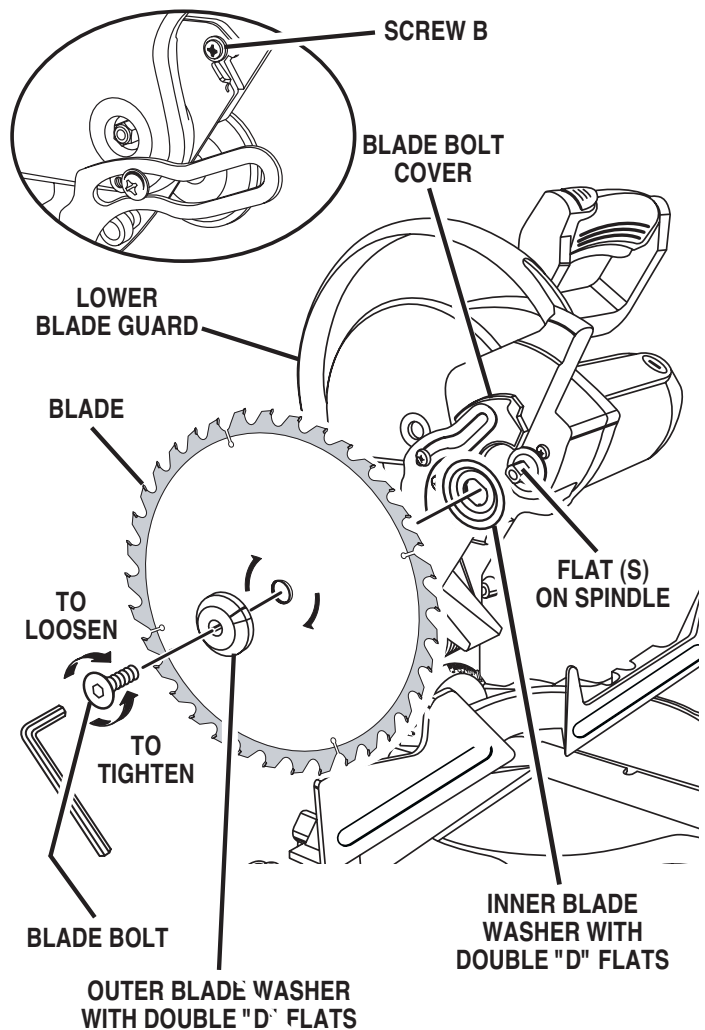

Fig. 12

ASSEMBLY

- Fit saw blade inside lower blade guard and onto spindle. The blade teeth point downward at the front of saw as shown in figure 12.
- Replace outer blade washer. The double "D" flats on the blade washers align with the flats on the spindle.
- Depress spindle lock button and replace blade bolt.

Note: The blade bolt has left hand threads. Turn blade bolt counterclockwise to tighten.

⚠ CAUTION:

Always install the blade with the blade teeth and the arrow printed on the side of the blade pointing down at the front of the saw. The direction of blade rotation is also stamped with an arrow on the upper blade guard.

- Tighten blade bolt securely.
- Replace the lower blade guard and blade bolt cover.
- Replace screw B and tighten securely.

ADJUSTMENTS

Note: Many of the illustrations in this manual show only portions of your compound miter saw. This is intentional so that we can clearly show points being made in the illustrations. Never operate your saw without all guards securely in place and in good operating condition.

SQUARING THE SAW BLADE TO THE FENCE

See Figures 13 - 17

- Unplug your saw.

⚠ WARNING:

Failure to unplug your saw could result in accidental starting causing possible serious personal injury.

- Remove the screws holding the throat plate in place. Remove the throat plate.
- Pull the saw arm all the way down and engage the lock pin to hold the saw arm in transport position.
- Loosen the miter lock handle approximately one-half turn.
- Depress the miter lock plate and rotate the miter table until the pointer on the control arm is positioned at 0°.
- Release the miter lock plate and securely tighten the miter lock handle.

⚠ WARNING:

Make sure the spindle lock button is not engaged before reconnecting saw into power source. Never engage spindle lock button when blade is rotating.

Your compound miter saw has been adjusted at the factory for making very accurate cuts. However, some of the components might have been jarred out of alignment during shipping. Also, over a period of time, readjustment will probably become necessary due to wear. After unpacking your saw, check the following adjustments before you begin using saw. Make any readjustments that are necessary and periodically check the parts alignment to make sure that your saw is cutting accurately.

⚠ WARNING:

Your saw should never be connected to power supply when you are assembling parts, making adjustments, installing or removing blades, or when not in use. Disconnecting your saw will prevent accidental starting that could cause serious injury.

- Remove the sliding miter fence by loosening the set screw and the sliding miter fence knob.
- Lay a framing square flat on the miter table. Place one leg of the square against the fence. Slide the other leg of the square against the flat part of saw blade.

Note: Make sure that the square contacts the flat part of the saw blade, not the blade teeth.

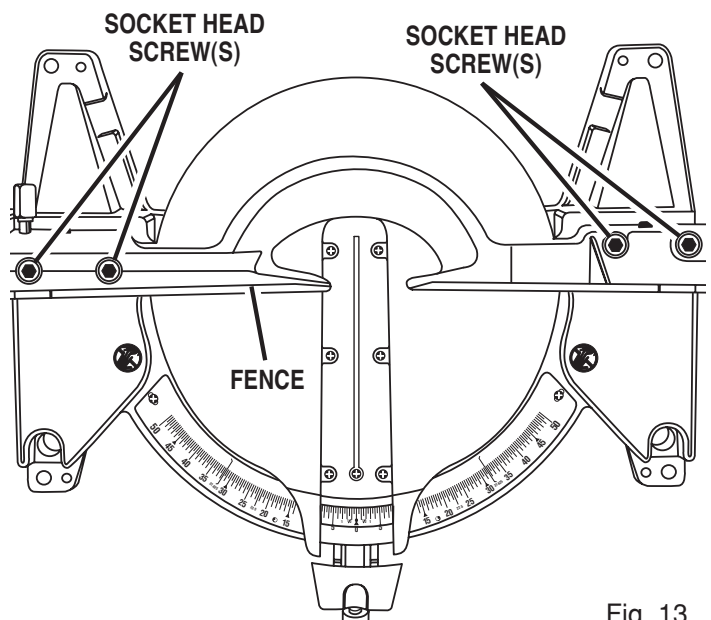
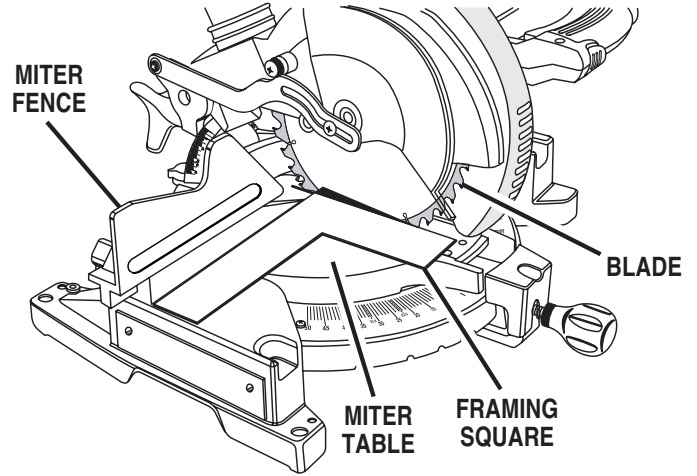

Fig. 13

ADJUSTMENTS

- The edge of the square and the saw blade should be parallel as shown in figure 14.
- If the front or back edge of the saw blade angles away from the square as shown in figures 15 and 16, adjustments are needed.
- Loosen the socket head screws that secure the miter fence to the miter table. See Figure 13.
- Rotate the miter fence left or right until the saw blade is parallel with the square.
- Retighten the screws securely and recheck the blade-to-fence alignment.
- Insert the throat plate, lower the blade and secure with the screws. Tighten firmly. See page 18 for instruction regarding “cutting a slot in the zero clearance throat plate”.

Your saw has scale indicators. After squaring adjustments have been made, it may be necessary to loosen the indicators screws and reset them to zero. See Figure 17.



VIEW OF BLADE NOT SQUARE WITH FENCE, ADJUSTMENTS ARE REQUIRED

Fig. 15

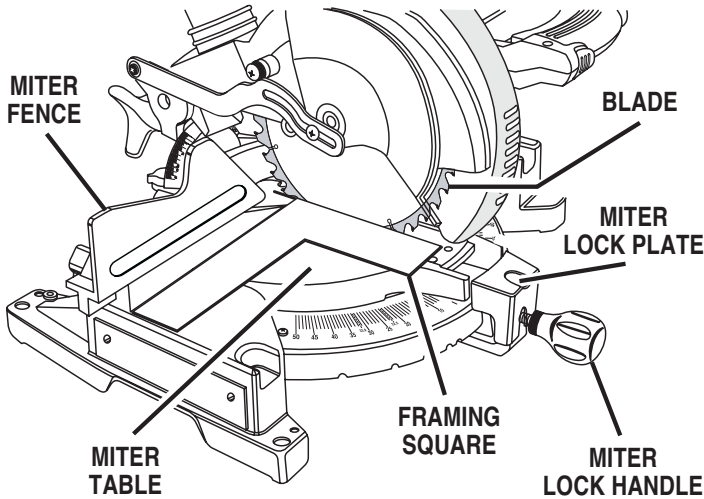

VIEW OF BLADE SQUARE WITH FENCE

Fig. 14

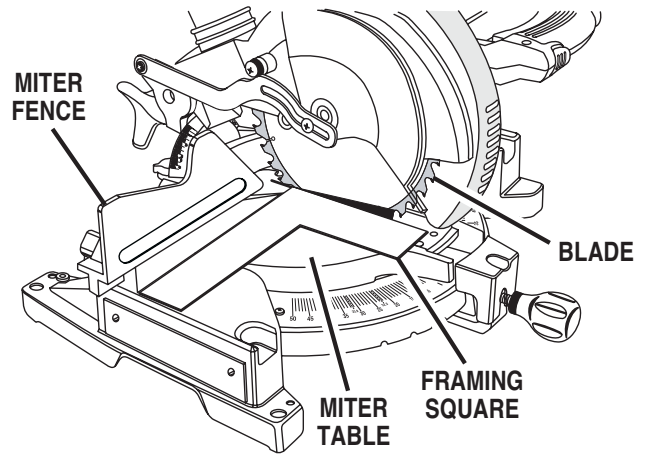

VIEW OF BLADE NOT SQUARE WITH FENCE, ADJUSTMENTS ARE REQUIRED

Fig. 16

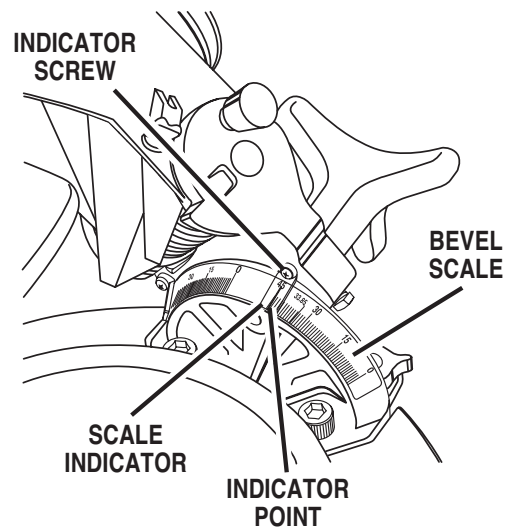
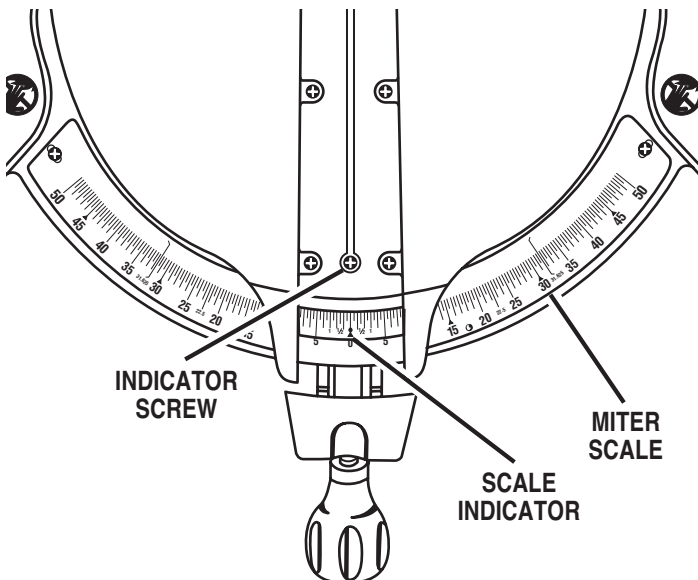

Fig. 17

ADJUSTMENTS

SQUARING THE BLADE TO THE MITER TABLE

See Figures 18 - 20.

- Unplug your saw.

⚠ WARNING:

Failure to unplug your saw could result in accidental starting causing possible serious personal injury.

- Pull the saw arm all the way down and engage the lock pin to hold the saw arm in transport position.
- Loosen the miter lock handle approximately one-half turn.
- Depress the miter lock plate and rotate the miter table until the pointer on the control arm is positioned at 0°.
- Release the miter lock plate and securely tighten the miter lock handle.
- Loosen bevel lock knob and set saw arm at 0° bevel (blade set 90° to miter table). Tighten bevel lock knob.
- Place a combination square against the miter table and the flat part of saw blade.

Note: Make sure that the square contacts the flat part of the saw blade, not the blade teeth.

- Rotate the blade by hand and check the blade-to-table alignment at several points.
- The edge of the square and the saw blade should be parallel as shown in figure 18.
- If the top or bottom of the saw blade angles away from the square as shown in figures 19 and 20, adjustments are needed.
- Loosen the lock nut securing positive stop adjustment screw. Also loosen bevel lock knob.
- Adjust positive stop adjustment screw to bring saw blade into alignment with the square. See Figure 21.
- Retighten bevel lock knob. Next, retighten lock nut securing the positive stop adjustment screw. Recheck blade-to-table alignment.

Note: The above procedure can be used to check blade squareness of the saw blade to the miter table at both 0° and 45° angles.

Your saw has several scale indicators. After squaring adjustments have been made, it may be necessary to loosen the indicators screws and reset them to zero. See Figure 17.

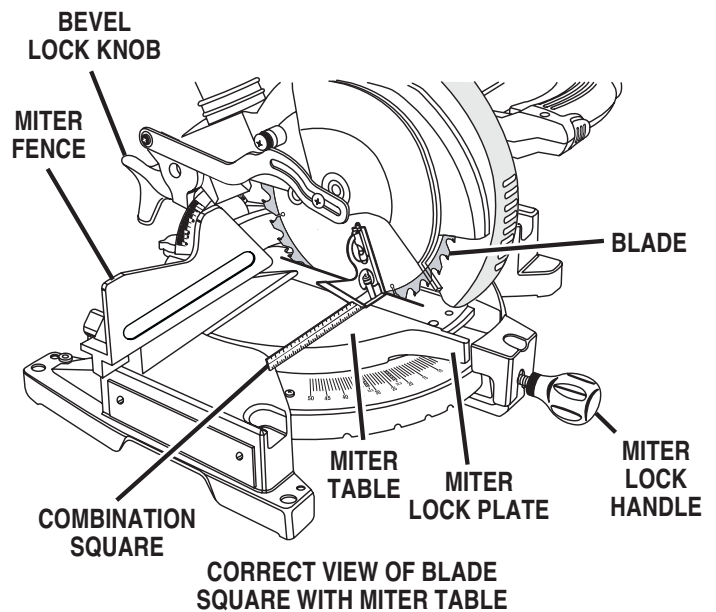
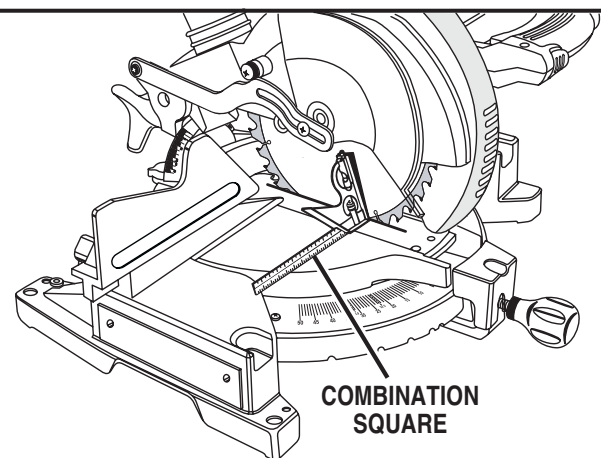
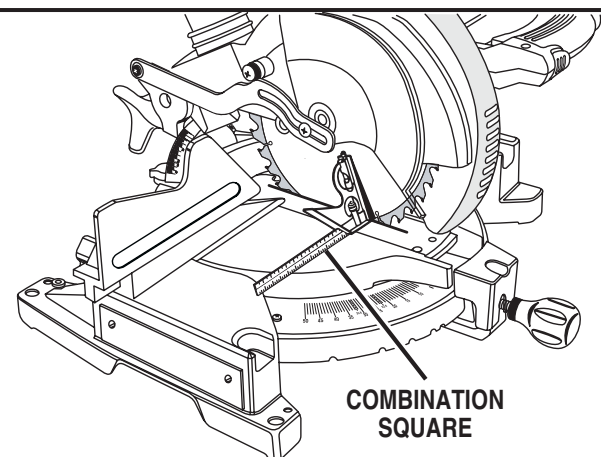

Fig. 18



VIEW OF BLADE NOT SQUARE WITH MITER TABLE, ADJUSTMENTS ARE REQUIRED

Fig. 19



VIEW OF BLADE NOT SQUARE WITH MITER TABLE, ADJUSTMENTS ARE REQUIRED

Fig. 20

ADJUSTMENTS

PIVOT ADJUSTMENTS

Note: These adjustments were made at the factory and normally do not require readjustment.

TRAVEL PIVOT ADJUSTMENT

- The saw arm should rise completely to the up position by itself.
- If the saw arm does not raise by itself or if there is play in the pivot joints, have saw repaired by at your nearest **AUTHORIZED SERVICE CENTER**.

BEVEL PIVOT ADJUSTMENT

- Your compound miter saw should bevel easily by loosening the bevel lock knob and tilting the saw arm to the left.
- If movement is tight or if there is play in the pivot, have saw repaired by at your nearest **AUTHORIZED SERVICE CENTER**.

⚠ WARNING:

Do not start your compound miter saw without checking for interference between the blade and the miter table support. Damage could result to the blade if it strikes the miter table support during operation of the saw.

OPERATION

⚠ WARNING:

Before starting any cutting operation, clamp or bolt your miter saw to a workbench. Never operate your miter saw on the floor or in a crouched position. Failure to heed this warning can result in serious personal injury.

⚠ WARNING:

To avoid serious personal injury, keep your hands outside the no hands zone; at least 3 in. (7.6 cm) from blade. Never perform any cutting operation freehand (without holding workpiece against the fence). The blade could grab the workpiece if it slips or twists.

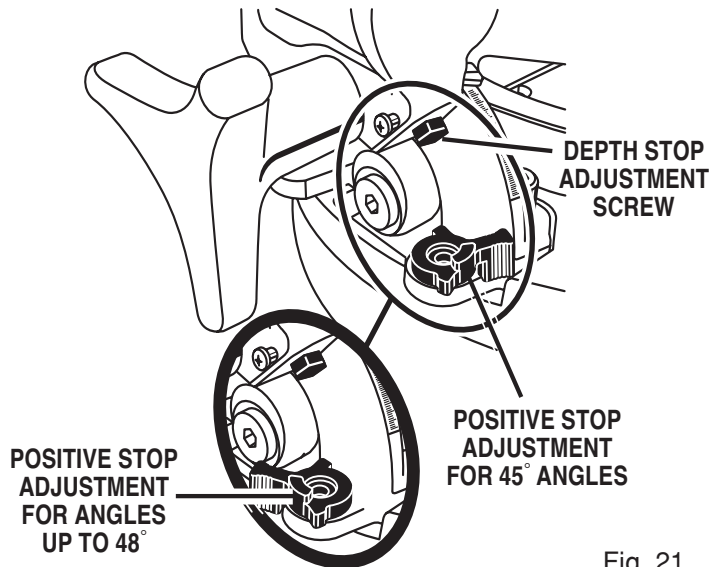

Fig. 21

APPLICATIONS

(Use only for the purposes listed below)

- Cross cutting wood and plastic.
- Cross cutting miters, joints, etc. for picture frames, moldings, door casings, and fine joinery.

Note: The blade provided is fine for most wood cutting operations, but for fine joinery cuts or cutting plastic, use one of the accessory blades available from your dealer.

CUTTING A SLOT IN THE ZERO CLEARANCE THROAT PLATE

In order to use your compound miter saw, you must cut a slot through the zero clearance throat plate to allow for blade clearance. To cut the slot, set your saw at 0° miter, turn saw on and allow the blade to reach full speed, then carefully make a straight cut as far as it will go through the throat plate. Turn your saw off and allow the blade to come to a complete stop before raising the saw arm.

Next, adjust the bevel angle to 45°, turn your saw on and allow the blade to reach full speed, then carefully make another cut through the zero clearance throat plate. The slot in the throat plate will then be wide enough to allow the blade to pass through it at any angle from 0° to 45°.

OPERATION

CUTTING WITH YOUR COMPOUND MITER SAW

⚠ WARNING:

When using a work clamp or C-clamp to secure your workpiece, clamp workpiece on one side of the blade only. The workpiece must remain free on one side of the blade to prevent the blade from binding in workpiece. The workpiece binding the blade will cause motor stalling and kickback. This situation could cause an accident resulting in possible serious personal injury.

CROSSCUTTING

See Figure 22.

A crosscut is made by cutting across the grain of the workpiece. A straight crosscut is made with the miter table set at the 0° position. Miter crosscuts are made with the miter table set at some angle other than zero.

TO CROSSCUT WITH YOUR MITER SAW

- Pull out the lock pin and lift saw arm to its full height.
- Loosen the miter lock handle. Rotate the miter lock handle approximately one-half turn to the left to loosen.
- Press the miter lock plate down with your thumb and hold.
- Rotate the control arm until the pointer aligns with the desired angle on the miter scale.
- Release the miter lock plate.

Note: You can quickly locate 0°, 11.25°, 15°, 22.5°, 31.62°, and 45° left or right by releasing the lock plate as you rotate the control arm. The lock plate will seat itself in one of the positive stop notches, located in the miter table frame.

- Tighten the miter lock handle securely.

⚠ WARNING:

To avoid serious personal injury, always tighten the miter lock handle securely before making a cut. Failure to do so could result in movement of the control arm or miter table while making a cut.

- Place the workpiece flat on the miter table with one edge securely against the fence. If the board is warped, place the convex side against the fence. If the concave edge of a board is placed against the fence, the board could collapse on the blade at the end of the cut, jamming the blade. See Figures 30 and 31.
- When cutting long pieces of lumber or molding, support the opposite end of the stock with a roller stand or with a work surface level with the saw table. See Figure 28.

- Align cutting line on the workpiece with the edge of saw blade.
- Grasp the stock firmly with one hand and secure it against the fence. Use the optional work clamp or a C-clamp to secure the workpiece when possible. See Figure 22.
- Before turning on the saw, perform a dry run of the cutting operation just to make sure that no problems will occur when the cut is made.
- Grasp the saw handle firmly then squeeze the switch trigger. Allow several seconds for the blade to reach maximum speed.
- Slowly lower the blade into and through the workpiece. See Figure 22.
- Release the switch trigger and allow the saw blade to stop rotating before raising the blade out of workpiece. Wait until the electric brake stops blade from turning before removing the workpiece from the miter table.

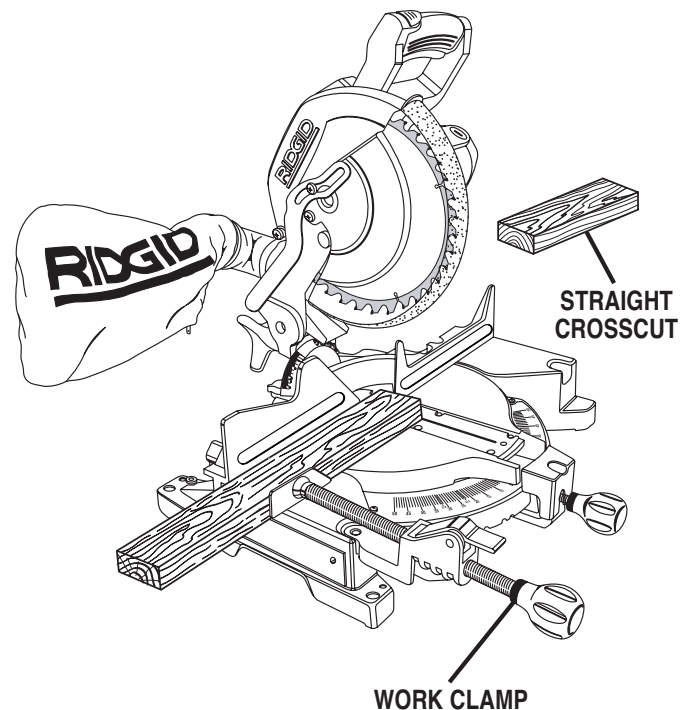

Fig. 22

OPERATION

BEVEL CUT

See Figures 23 - 25.

A bevel cut is made by cutting across the grain of the workpiece with the blade angled to the workpiece. A straight bevel cut is made with the miter table set at the zero degree position and the blade set at an angle between 0° and 48°.

Note: It may be necessary to adjust the sliding miter fence to assure proper clearance prior to making the cut.

- Pull out the lock pin and lift saw arm to its full height.
- Loosen the miter lock handle. Rotate the miter lock handle approximately one-half turn to the left to loosen.
- Press the miter lock plate down with your thumb and hold.
- Rotate the control arm until the pointer aligns with zero on the miter scale.
- Release the miter lock plate.

Note: You can quickly locate zero by releasing the lock plate as you rotate the control arm. The lock plate will seat itself in one of the built-in positive stop notches, located in the miter table frame.

- Tighten the miter lock handle securely.

⚠ WARNING:

To avoid serious personal injury, always tighten the miter lock handle securely before making a cut. Failure to do so could result in movement of the control arm or miter table while making a cut.

- Loosen the bevel lock knob and move the saw arm to the left to the desired bevel angle.
- Bevel angles can be set from 0° to 48°. See Figure 25.

Note: Turn the bevel override clockwise to gain an extra 3° on the bevel angle (from 45° to 48°) of the cut.

- Once the saw arm has been set at the desired angle, securely tighten the bevel lock knob.
- Place the workpiece flat on the miter table with one edge securely against the fence. If the board is warped, place the convex side against the fence. If the concave edge of a board is placed against the fence, the board could collapse on the blade at the end of the cut, jamming the blade. See Figures 30 and 31.
- When cutting long pieces of lumber or molding, support the opposite end of the stock with a roller stand or with a work surface level with the saw table. See Figure 28.
- Align the cutting line on the workpiece with the edge of saw blade.

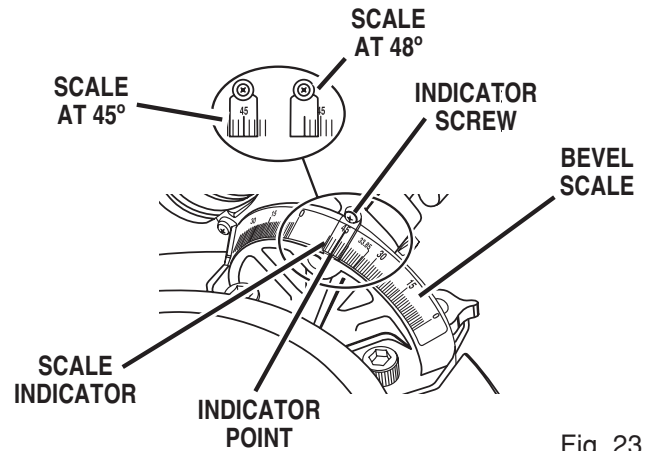

Fig. 23

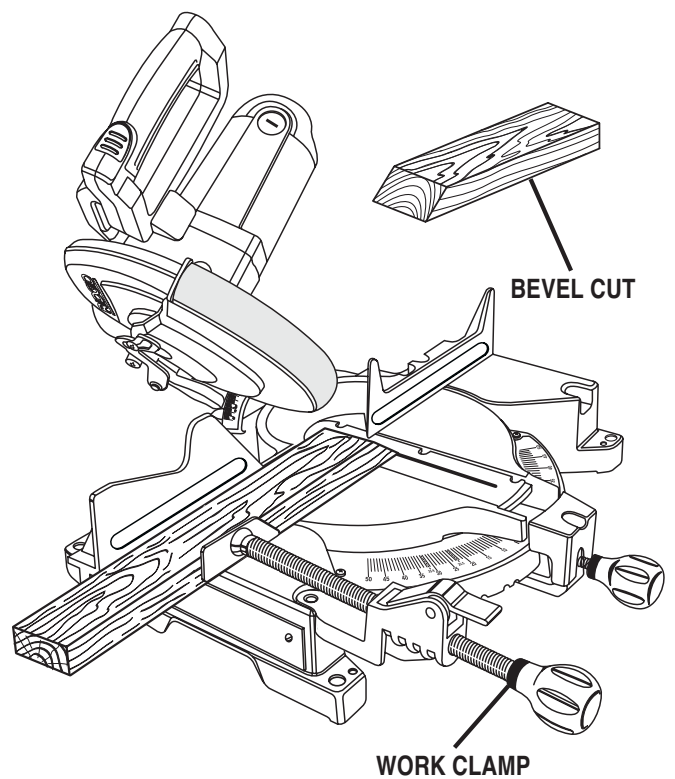

Fig. 24

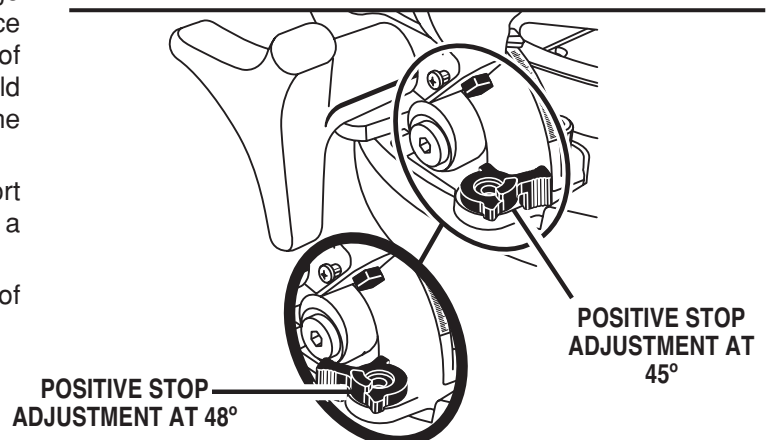

Fig. 25

OPERATION

- Grasp the stock firmly with one hand and secure it against the fence. Use the optional work clamp or a C-clamp to secure the workpiece when possible. See Figure 24.

⚠ WARNING:

To avoid serious personal injury, always keep your hands outside the no hands zone; at least 3 in. (7.6 cm) from blade. Never perform any cutting operation freehand (without holding workpiece against the fence). The blade could grab the workpiece if it slips or twists.

- Before turning on the saw, perform a dry run of the cutting operation just to make sure that no problems will occur when the cut is made.
- Grasp the saw handle firmly then squeeze the switch trigger. Allow several seconds for the blade to reach maximum speed.
- Slowly lower the blade into and through the workpiece. See Figure 26.
- Release the switch trigger and allow the saw blade to stop rotating before raising the blade out of workpiece. Wait until the electric brake stops blade from turning before removing the workpiece from miter table.

COMPOUND MITER CUT

A compound miter cut is a cut made using a miter angle and a bevel angle at the same time. This type of cut is used to make picture frames, cut molding, make boxes with sloping sides, and for certain roof framing cuts.

To make this type of cut the control arm on the miter table must be rotated to the correct angle and the saw arm must be tilted to the correct bevel angle. Care should always be taken when making compound miter setups due to the interaction of the two angle settings.

Adjustments of miter and bevel settings are interdependent with one another. Each time you adjust the miter setting you change the effect of the bevel setting. Also, each time you adjust the bevel setting you change the effect of the miter setting.

It may take several settings to obtain the desired cut. The first angle setting should be checked after setting the second angle, since adjusting the second angle affects the first.

Once the two correct settings for a particular cut have been obtained, always make a test cut in scrap material before making a finish cut in good material.

TO MAKE A COMPOUND CUT WITH YOUR MITER SAW

- Pull out the lock pin and lift saw arm to its full height.
- Loosen the miter lock handle. Rotate the miter lock handle approximately one-half turn to the left to loosen.
- Press the miter lock plate down with your thumb and hold.

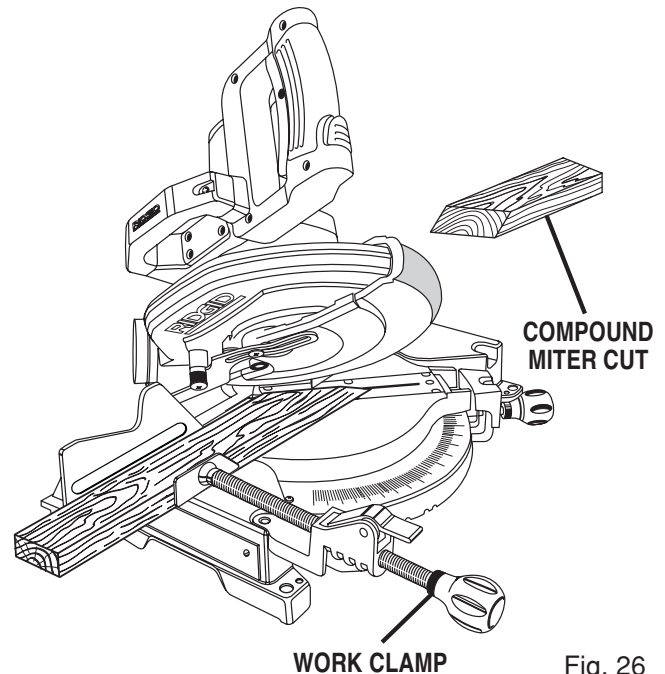

Fig. 26

- Rotate the control arm until the pointer aligns with the desired angle on the miter scale.
- Release the miter lock plate.
Note: You can quickly locate 0°, 11.25°, 15°, 22.5°, 31.62°, and 45° left or right by releasing the miter lock plate as you rotate the control arm. The miter lock plate will seat itself in one of the positive stop notches, located in miter table frame.
- Tighten the miter lock handle securely.

⚠ WARNING:

To avoid serious personal injury, always tighten the miter lock handle securely before making a cut. Failure to do so could result in movement of the control arm or miter table while making a cut.

- Loosen the bevel lock knob and move the saw arm to the left to the desired bevel angle.
- Bevel angles can be set from 0° to 48°.
- Once the saw arm has been set at the desired angle, securely tighten the bevel lock knob.
- Recheck miter angle setting. Make a test cut in scrap material.
- Place the workpiece flat on the miter table with one edge securely against the fence. If the board is warped, place the convex side against the fence. If the concave edge of a board could collapse on the blade at the end of the cut, jamming the blade. See Figures 30 and 31.
- When cutting long pieces of lumber or molding, support the opposite end of the stock with a roller stand or with a work surface level with the saw table. See Figure 28.

OPERATION

- Align the cutting line on the workpiece with the edge of saw blade.
- Grasp the stock firmly with one hand and secure it against the fence. Use the optional work clamp or a C-clamp to secure the workpiece when possible. See Figure 26.

⚠ WARNING:

To avoid serious personal injury, always keep your hands outside the no hands zone; at least 3 in. (7.6 cm) from blade. Never perform any cutting operation freehand (without holding workpiece against the fence). The blade could grab the workpiece if it slips or twists.

- Before turning on the saw, perform a dry run of the cutting operation just to make sure that no problems will occur when the cut is made.
- Grasp the saw handle firmly then squeeze the switch trigger. Allow several seconds for the blade to reach maximum speed.
- Slowly lower the blade into and through the workpiece. See Figures 26 and 27.
- Release the switch trigger and allow the saw blade to stop rotating before raising the blade out of workpiece. Wait until the electric brake stops blade from turning before removing the workpiece from miter table.

SUPPORT LONG WORKPIECES

See Figure 28.

Long workpieces need extra supports. Supports should be placed along the workpiece so it does not sag. The support should let the workpiece lay flat on the base of the saw and work table during the cutting operation. Use the optional work clamp or a C-clamp to secure the workpiece.

⚠ WARNING:

To avoid serious personal injury, always keep your hands outside the no hands zone; at least 3 in. (7.6 cm) from blade. Never perform any cutting operation freehand (without holding workpiece against the fence). The blade could grab the workpiece if it slips or twists.

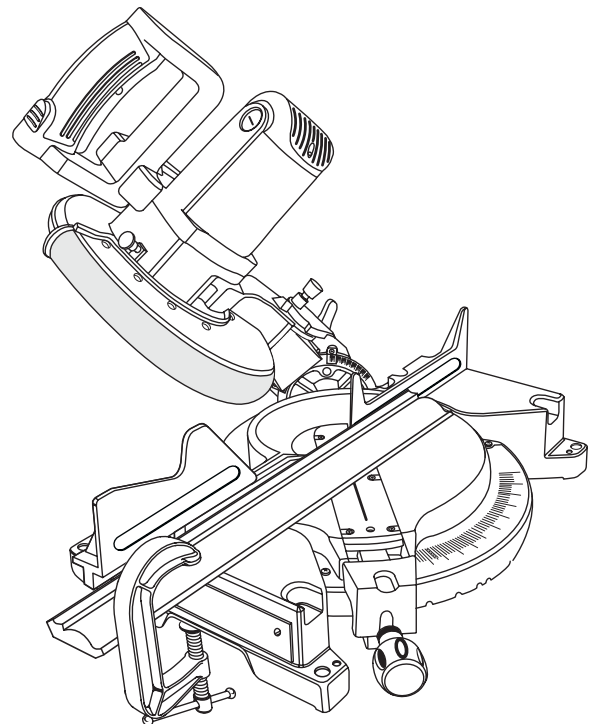

45° X 45° COMPOUND MITER CUT

Fig. 27

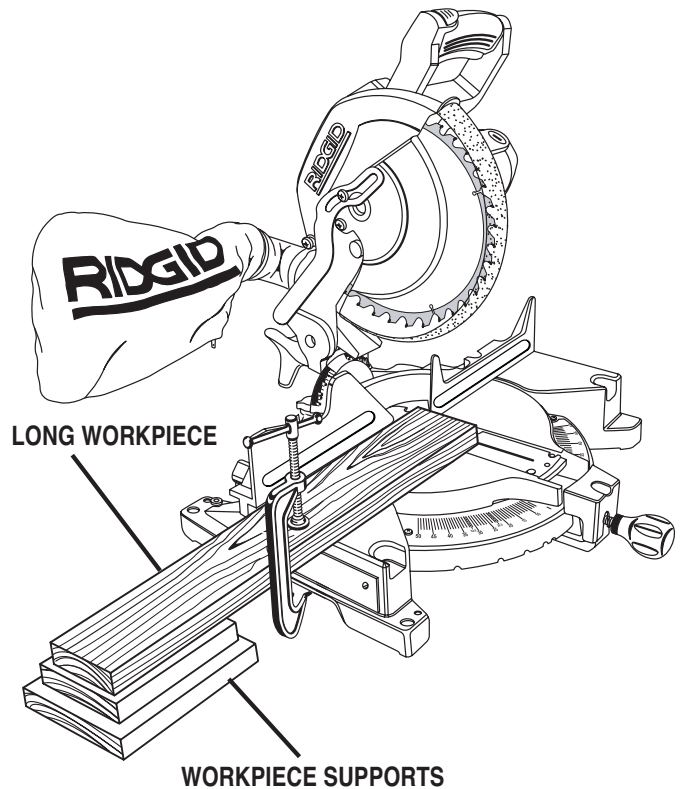

LONG WORKPIECE

WORKPIECE SUPPORTS

Fig. 28

OPERATION

CUTTING COMPOUND MITERS

To aid in making the correct settings, the compound angle setting chart below has been provided. Since compound cuts are the most difficult to accurately obtain, trial cuts should be made in scrap material, and much thought and planning made, prior to making your required cut.

| PITCH OF SIDE | NUMBER OF SIDES | | | | | | |
|---------------|------------------------|------------------------|------------------------|------------------------|------------------------|------------------------|------------------------|
| | 4 | 5 | 6 | 7 | 8 | 9 | 10 |
| 0° | M- 45.00° B- 0.00° | M- 36.00° B- 0.00° | M- 30.00° B- 0.00° | M- 25.71° B- 0.00° | M- 22.50° B- 0.00° | M- 20.00° B- 0.00° | M- 18.00° B- 0.00° |
| 5° | M- 44.89° B- 3.53° | M- 35.90° B- 2.94° | M- 29.91° B- 2.50° | M- 25.63° B- 2.17° | M- 22.42° B- 1.91° | M- 19.93° B- 1.71° | M- 17.94° B- 1.54° |
| 10° | M- 44.56° B- 7.05° | M- 35.58° B- 5.86° | M- 29.62° B- 4.98° | M- 25.37° B- 4.32° | M- 22.19° B- 3.81° | M- 19.72° B- 3.40° | M- 17.74° B- 3.08° |
| 15° | M- 44.01° B- 10.55° | M- 35.06° B- 8.75° | M- 29.15° B- 7.44° | M- 24.95° B- 6.45° | M- 21.81° B- 5.68° | M- 19.37° B- 5.08° | M- 17.42° B- 4.59° |
| 20° | M- 43.22° B- 14.00° | M- 34.32° B- 11.60° | M- 28.48° B- 9.85° | M- 24.35° B- 8.53° | M- 21.27° B- 7.52° | M- 18.88° B- 6.72° | M- 16.98° B- 6.07° |
| 25° | M- 42.19° B- 17.39° | M- 33.36° B- 14.38° | M- 27.62° B- 12.20° | M- 23.56° B- 10.57° | M- 20.58° B- 9.31° | M- 18.26° B- 8.31° | M- 16.41° B- 7.50° |
| 30° | M- 40.89° B- 20.70° | M- 32.18° B- 17.09° | M- 26.57° B- 14.48° | M- 22.64° B- 12.53° | M- 19.73° B- 11.03° | M- 17.50° B- 9.85° | M- 15.72° B- 8.89° |
| 35° | M- 39.32° B- 23.93° | M- 30.76° B- 19.70° | M- 25.31° B- 16.67° | M- 21.53° B- 14.41° | M- 18.74° B- 12.68° | M- 16.60° B- 11.31° | M- 14.90° B- 10.21° |
| 40° | M- 37.45° B- 27.03° | M- 29.10° B- 22.20° | M- 23.86° B- 18.75° | M- 20.25° B- 16.19° | M- 17.60° B- 14.24° | M- 15.58° B- 12.70° | M- 13.98° B- 11.46° |
| 45° | M- 35.26° B- 30.00° | M- 27.19° B- 24.56° | M- 22.21° B- 20.70° | M- 18.80° B- 17.87° | M- 16.32° B- 15.70° | M- 14.43° B- 14.00° | M- 12.94° B- 12.62° |
| 50° | M- 32.73° B- 32.80° | M- 25.03° B- 26.76° | M- 20.36° B- 22.52° | M- 17.20° B- 19.41° | M- 14.91° B- 17.05° | M- 13.17° B- 15.19° | M- 11.80° B- 13.69° |
| 55° | M- 29.84° B- 35.40° | M- 22.62° B- 28.78° | M- 18.32° B- 24.18° | M- 15.44° B- 20.82° | M- 13.36° B- 18.27° | M- 11.79° B- 16.27° | M- 10.56° B- 14.66° |
| 60° | M- 26.57° B- 37.76° | M- 19.96° B- 30.60° | M- 16.10° B- 25.66° | M- 13.54° B- 22.07° | M- 11.70° B- 19.35° | M- 10.31° B- 17.23° | M- 9.23° B- 15.52° |
| 65° | M- 22.91° B- 39.86° | M- 17.07° B- 32.19° | M- 13.71° B- 26.95° | M- 11.50° B- 23.16° | M- 9.93° B- 20.29° | M- 8.74° B- 18.06° | M- 7.82° B- 16.26° |
| 70° | M- 18.88° B- 41.64° | M- 13.95° B- 33.53° | M- 11.17° B- 28.02° | M- 9.35° B- 24.06° | M- 8.06° B- 21.08° | M- 7.10° B- 18.75° | M- 6.34° B- 16.88° |
| 75° | M- 14.51° B- 43.08° | M- 10.65° B- 34.59° | M- 8.50° B- 28.88° | M- 7.10° B- 24.78° | M- 6.12° B- 21.69° | M- 5.38° B- 19.29° | M- 4.81° B- 17.37° |
| 80° | M- 9.85° B- 44.14° | M- 7.19° B- 35.37° | M- 5.73° B- 29.50° | M- 4.78° B- 25.30° | M- 4.11° B- 22.14° | M- 3.62° B- 19.68° | M- 3.23° B- 17.72° |
| 85° | M- 4.98° B- 44.78° | M- 3.62° B- 35.84° | M- 2.88° B- 29.87° | M- 2.40° B- 25.61° | M- 2.07° B- 22.41° | M- 1.82° B- 19.92° | M- 1.62° B- 17.93° |
| 90° | M- 0.00° B- 45.00° | M- 0.00° B- 36.00° | M- 0.00° B- 30.00° | M- 0.00° B- 25.71° | M- 0.00° B- 22.50° | M- 0.00° B- 20.00° | M- 0.00° B- 18.00° |

Each B (Bevel) and M (Miter) Setting is Given to the Closest 0.005°.

COMPOUND-ANGLE SETTINGS FOR POPULAR STRUCTURES

OPERATION

CUTTING CROWN MOLDING

Your compound miter saw does an excellent job of cutting crown molding. In general, compound miter saws do a better job of cutting crown molding than any other tool made.

In order to fit properly, crown molding must be compound mitered with extreme accuracy.

The two contact surfaces on a piece of crown molding that fit flat against the ceiling and the wall of a room are at angles that, when added together, equal exactly 90°. Most crown molding has a top rear angle (the section that fits flat against the ceiling) of 52° and a bottom rear angle (the section that fits flat against the wall) of 38°.

LAYING MOLDING FLAT ON THE MITER TABLE

See Figure 29.

To use this method for accurately cutting crown molding for a 90° inside or outside corner, lay the molding with its broad back surface flat on the miter table and against the fence.

When setting the bevel and miter angles for compound miters, remember that the settings are interdependent; changing one angle changes the other angle as well.

Keep in mind that the angles for crown moldings are very precise and difficult to set. Since it is very easy for these angles to shift, all settings should first be tested on scrap molding. Also most walls do not have angles of exactly 90°, therefore, you will need to fine tune your settings.

When cutting crown molding by this method the bevel angle should be set at 33.85°. The miter angle should be set at 31.62° either right or left, depending on the desired cut for the application. See the chart below for correct angle settings and correct positioning of crown molding on miter table.

The settings in the chart below can be used for cutting All Standard (U.S.) crown molding with 52° and 38° angles. The crown molding is placed flat on the miter table using the compound features of your miter saw.

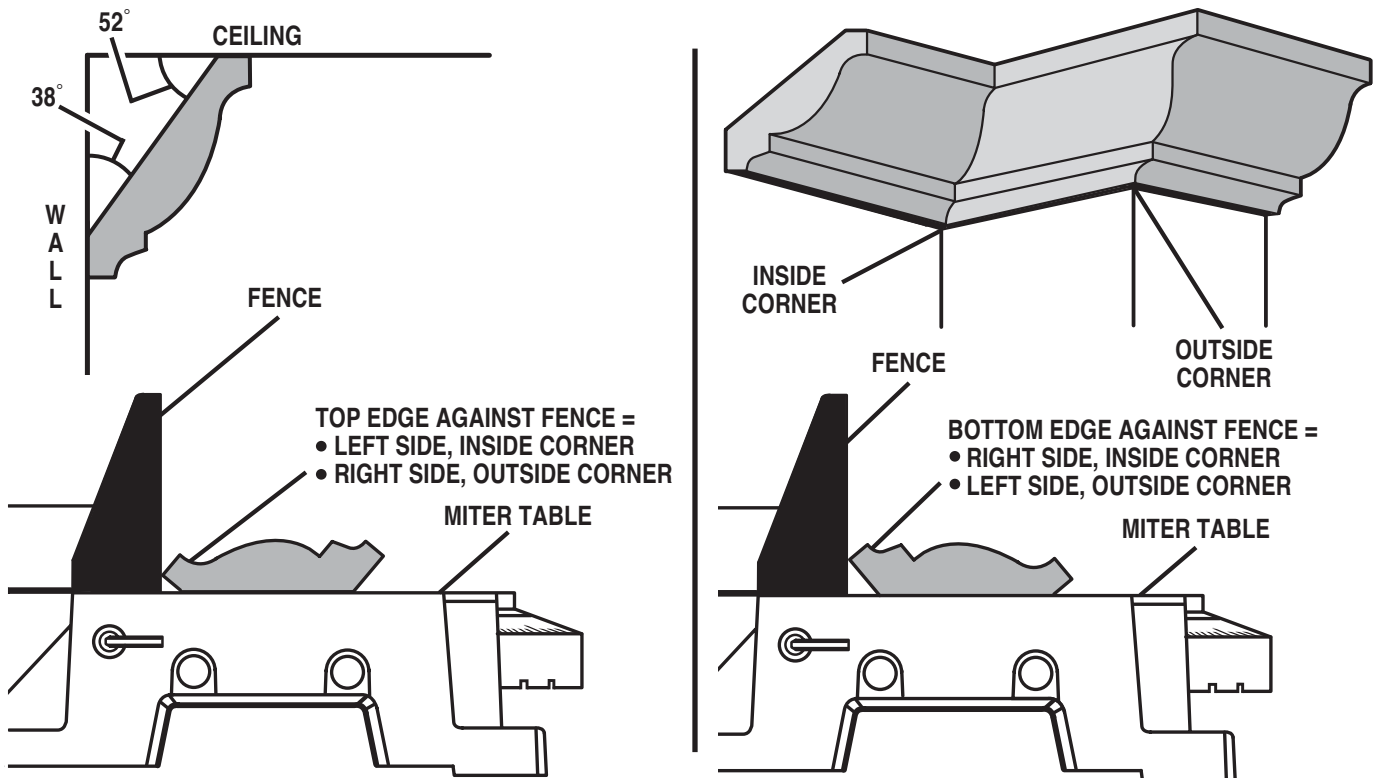

CROWN MOLDING FLAT ON MITER TABLE

Fig. 29

OPERATION

| Bevel Angle Setting | Type of Cut |
|---------------------|---|
| 33.85° | Left side, inside corner 1. Top edge of molding against fence 2. Miter table set right 31.62° 3. Save left end of cut |
| 33.85° | Right side, inside corner 1. Bottom edge of molding against fence 2. Miter table set left 31.62° 3. Save left end of cut |
| 33.85° | Left side, outside corner 1. Bottom edge of molding against fence 2. Miter table set left 31.62° 3. Save right end of cut |
| 33.85° | Right side, outside corner 1. Top edge of molding against fence 2. Miter table set right 31.62° 3. Save right end of cut |

CUTTING WARPED MATERIAL

See Figures 30 and 31.

When cutting warped material, always make sure it is positioned on the miter table with the convex side against the fence as shown in figure 30.

If the warped material is positioned the wrong way as shown in figure 31, it will pinch the blade near the completion of the cut.

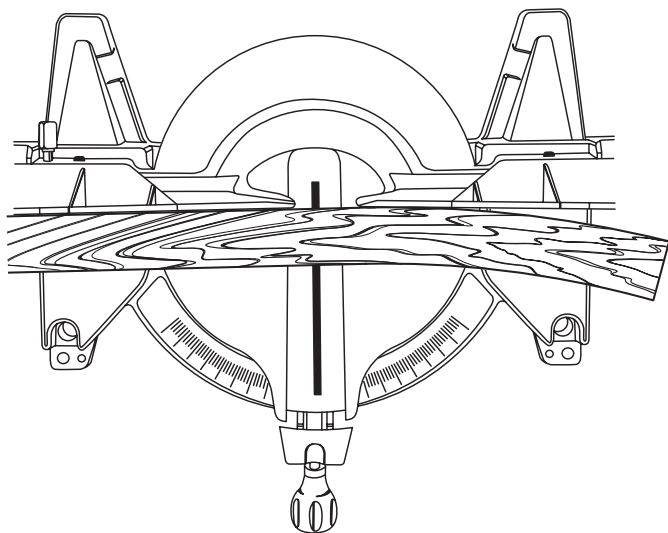
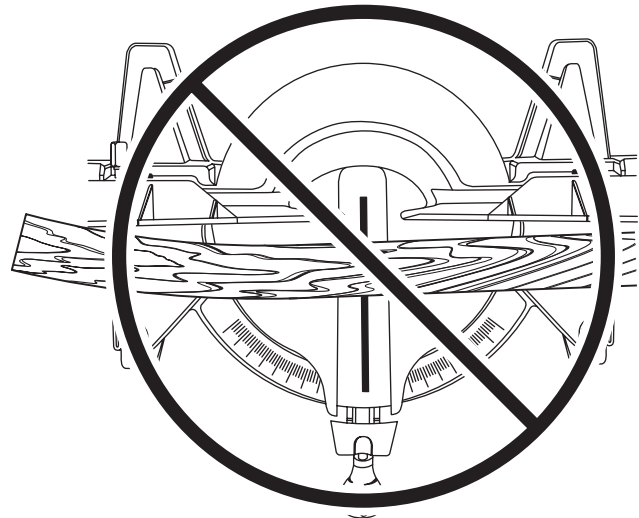

Fig. 30



WRONG

Fig. 31

⚠ WARNING:

To avoid a kickback and to avoid serious personal injury, never position the concave edge of bowed or warped material against the fence.

CLAMPING WIDE WORKPIECES

See Figure 32.

When cutting wide workpieces, such as 2 in. x 6 in., boards should be clamped with a C-clamp as shown in figure 32.

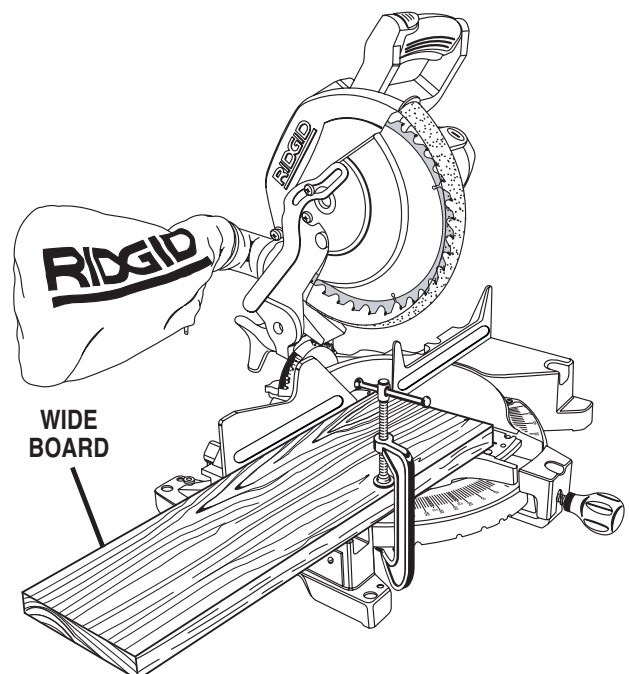

Fig. 32

LASER GUIDE

MOUNTING THE EXACTLINE™ LASER GUIDE

See Figure 33.

- Unplug your saw.

⚠ WARNING:

Failure to unplug your saw could result in accidental starting causing possible serious personal injury.

See "To Install Blade" in the adjustments section of this operator's manual.

- Make sure inner blade washer is in place before positioning saw blade on the spindle of your saw.

Note: The laser guide replaces the outer blade washer.

- Place the laser guide onto the spindle, aligning the double "D" flats in the laser guide with the flats on the spindle.
- Position flat surface of laser guide against the blade. Warning labels are visible when laser guide is mounted properly.
- Depress spindle lock button and secure laser guide using blade wrench provided.
- Note:** The hex key bolt has left hand threads. Turn bolt counterclockwise to tighten.
- Using the blade wrench provided with your saw, tighten bolt securely.
- Return the blade wrench to the wrench storage area.
- Replace the lower blade guard and blade bolt cover.
- Retighten phillips screw securing blade bolt cover. Tighten screw securely.

DANGER:

- ⚠ Laser radiation. Avoid direct eye contact with light source.

OPERATION

See Figure 34.

The laser guide will generate a red colored line on the work surface when the saw blade is spinning above 500 rpm. The red laser line will appear as a broken line on the workpiece when the blade assembly is in the uppermost position and the motor switch is activated. This broken line will let you see your mark and your laser guide line at the same time, and will assist you in lining up your mark for more accurate cutting of the workpiece.

ALIGNMENT

Align the laser line and your mark with the blade at the uppermost position. Once both lines are in alignment, do not move the workpiece until after you have finished cutting.

As the blade assembly is lowered toward the workpiece, the broken line will become solid.

Make several practice cuts on different styles and thickness of material.

Follow the directions below for using your Laser Guide.

Removing Your Mark:

Position the laser line near the left edge of your mark on the work surface in order to remove the mark.

To Cut Your Mark:

Position the laser line near or over your mark on the work surface in order to cut the mark.

To Leave Your Mark:

Position the laser line near the right edge of your mark on the work surface in order to leave the mark.

After you have become familiar with using your Laser Guide, you will be able to remove, cut, or leave your mark on the work surface. Practice will teach you the correct position for aligning the laser line with your mark.

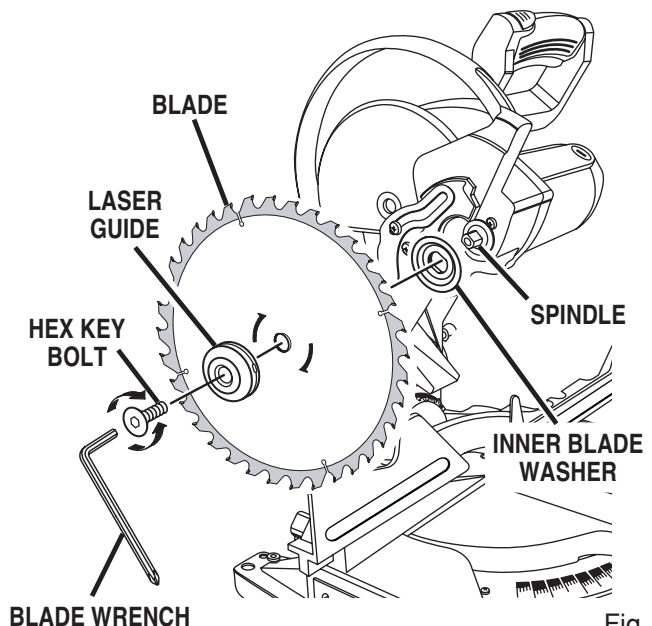

Fig. 33

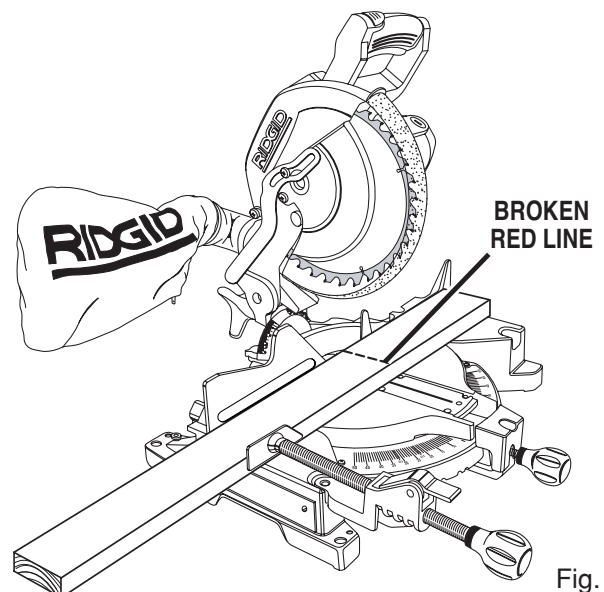

Fig. 34

MAINTENANCE

WARNING:

When servicing, use only identical replacement parts. Use of any other part may create a hazard or cause product damage.

GENERAL

Avoid using solvents when cleaning plastic parts. Most plastics are susceptible to damage from various types of commercial solvents and may be damaged by their use. Use clean cloths to remove dirt, carbon dust, etc.

WARNING:

Do not at any time let brake fluids, gasoline, petroleum-based products, penetrating oils, etc. come in contact with plastic parts. They contain chemicals that can damage, weaken or destroy plastic.

It has been found that electric tools are subject to accelerated wear and possible premature failure when they are used on fiberglass boats, sports cars, wallboard, spackling compounds, or plaster. The chips and grindings from these materials are highly abrasive to electric tool parts such as bearings, brushes, commutators, etc. Consequently, it is not recommended that this tool be used for extended work on any fiberglass material, wallboard, spackling compounds, or plaster. During any use on these materials it is extremely important that the tool is cleaned frequently by blowing with an air jet.

LUBRICATION

All of the bearings in this tool are lubricated with a sufficient amount of high grade lubricant for the life of the unit under normal operating conditions. Therefore, no further lubrication is required.

EXTENSION CORDS

The use of any extension cord will cause some loss of power. To keep the loss to a minimum and to prevent tool overheating, use an extension cord that is heavy enough to carry the current the tool will draw.

A wire gage size (A.W.G.) of at least **14** is recommended for an extension cord 25 feet or less in length. When working outdoors, use an extension cord that is suitable for outdoor use. The cord's jacket will be marked WA.

WARNING:

Keep extension cords away from the cutting area and position the cord so that it will not get caught on lumber, tools, etc., during cutting operation. Failure to heed this warning may result in serious personal injury.

CAUTION:

Check extension cords before each use. If damaged, replace immediately. Never use tool with a damaged cord since touching the damaged area could cause electrical shock resulting in serious injury.

WARNING:

Always wear safety goggles or safety glasses with side shields during power tool operation or when blowing dust. If operation is dusty, also wear a dust mask.

WARNING:

To ensure safety and reliability, all repairs should be performed by a qualified service technician at a Authorized Service Center to avoid risk of personal injury.

WARRANTY

RIDGID® HAND HELD AND STATIONARY POWER TOOL LIMITED THREE YEAR WARRANTY AND 90-DAY SATISFACTION GUARANTEE POLICY

This product is manufactured by One World Technologies, Inc., under a trademark license from Ridgid, Inc. All warranty communications should be directed to One World Technologies, Inc., attn: RIDGID handheld and stationary power tool technical service at (toll free) 1-866-539-1710.

90-DAY SATISFACTION GUARANTEE POLICY

During the first 90 days after the date of purchase, if you are dissatisfied with the performance of this RIDGID tool for any reason you may return the tool to the dealer from which it was purchased for a full refund or exchange. To receive a replacement tool you must present proof of purchase and return all original equipment packaged with the original product. The replacement tool will be covered by the limited warranty for the balance of the three year warranty period.

WHAT IS COVERED UNDER THE LIMITED THREE YEAR WARRANTY

This warranty covers all defects in workmanship or materials in this RIDGID tool for the three year period from the date of purchase. This warranty is specific to this tool. Warranties for other RIDGID products may vary.

HOW TO OBTAIN SERVICE

To obtain service for this RIDGID tool you must return it, freight prepaid, to an authorized RIDGID service center for hand held and stationary power tools. You may obtain the location of the authorized service center nearest you by calling (toll free) 1-866-539-1710 or by logging on to the RIDGID website at www.ridgid.com. When requesting warranty service, you must present the proof of purchase documentation, which includes a date of purchase. The authorized service center will repair any faulty workmanship, and either repair or replace any defective part, at our option at no charge to you.

WHAT IS NOT COVERED

This warranty applies only to the original purchaser at retail and may not be transferred. This warranty only covers defects arising under normal usage and does not cover any malfunction, failure or defect resulting from misuse, abuse, neglect, alteration, modification or repair by other than an authorized service center for RIDGID branded hand held and stationary power tools. **RIDGID, INC. AND ONE WORLD TECHNOLOGIES, INC. MAKE NO WARRANTIES, REPRESENTATIONS OR PROMISES AS TO THE QUALITY OR PERFORMANCE OF ITS POWER TOOLS OTHER THAN THOSE SPECIFICALLY STATED IN THIS WARRANTY.**

ADDITIONAL LIMITATIONS

To the extent permitted by applicable law, all implied warranties, including warranties of MERCHANTABILITY or FITNESS FOR A PARTICULAR PURPOSE, are disclaimed. Any implied warranties, including warranties of merchantability or fitness for a particular purpose, that cannot be disclaimed under state law are limited to three years from the date of purchase. One World Technologies, Inc. is not responsible for direct, indirect, incidental or consequential damages. Some states do not allow limitations on how long an implied warranty lasts and/or do not allow the exclusion or limitation of incidental or consequential damages, so the above limitations may not apply to you. This warranty gives you specific legal rights, and you may also have other rights which vary from state to state.

One World Technologies, Inc.

Hwy. 8

Pickens, SC 29671

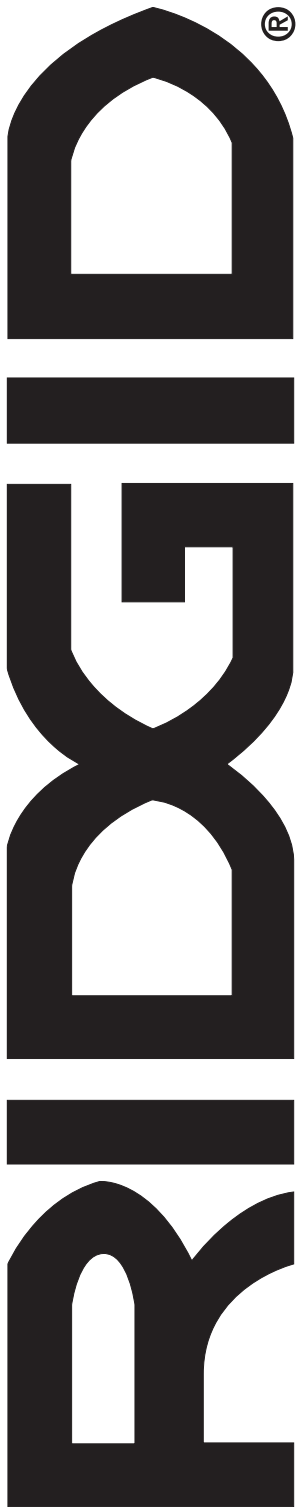

OPERATOR'S MANUAL

10 in. (254 mm)

COMPOUND MITER SAW

WITH EXACTLINE™ LASER

MS1065LZ - Double Insulated

CUSTOMER SERVICE INFORMATION

For parts or service, contact your nearest Ridgid authorized service center. Be sure to provide all relevant information when you call or visit. For the location of the authorized service center nearest you, please call 1-866-539-1710 or visit us online at www.ridgid.com.

The model number of this tool is found on a plate attached to the motor housing. Please record the serial number in the space provided below. When ordering repair parts, always give the following information:

Model No. MS1065LZ

Serial No. _____

Free Manuals Download Website

<http://myh66.com>

<http://usermanuals.us>

<http://www.somanuals.com>

<http://www.4manuals.cc>

<http://www.manual-lib.com>

<http://www.404manual.com>

<http://www.luxmanual.com>

<http://aubethermostatmanual.com>

Golf course search by state

<http://golfingnear.com>

Email search by domain

<http://emailbydomain.com>

Auto manuals search

<http://auto.somanuals.com>

TV manuals search

<http://tv.somanuals.com>