

AD-385

Installation/Operator's Manual

WARNING: For your safety the information in this manual must be followed to minimize the risk of fire or explosion or to prevent property damage, personal injury or death.

—Do not store or use gasoline or other flammable vapor and liquids in the vicinity of this or any other appliance.

—WHAT DO YOU DO IF YOU SMELL GAS

- * Do not try to light any appliance.
- * Do not touch any electrical switch; do not use any phone in your building.
- * Clear the room, building or area of all occupants.
- * Immediately call your gas supplier from a neighbor's phone. Follow the gas supplier's instructions.
- * If you cannot reach your gas supplier, call the fire department.

—Installation and service must be performed by a qualified installer, service agency or the gas supplier.

AVERTISSEMENT: Assurez-vous de bien suivre les instructions données dans cette notice pour réduire au minimum le risque d'incendie ou d'explosion ou pour éviter tout dommage matériel, toute blessure ou la mort.

—Ne pas entreposer ni utiliser d'essence ni d'autres vapeurs ou liquides inflammables dans le voisinage de cet appareil ou de tout autre appareil.

—QUE FAIRE SI VOUS SENTEZ UNE ODEUR DE GAZ:

- * Ne pas tenter d'allumer d'appareil.
- * Ne touchez à aucun interrupteur. Ne pas vous servir des téléphones se trouvant dans le bâtiment où vous vous trouvez.
- * Évacuez la pièce, le bâtiment ou la zone.
- * Appelez immédiatement votre fournisseur de gaz depuis un voisin. Suivez les instructions du fournisseur.
- * Si vous ne pouvez rejoindre le fournisseur de gaz, appelez le service des incendies.

—L'installation et l'entretien doivent être assurés par un installateur ou un service d'entretien qualifié ou par le fournisseur de gaz.



For replacement parts, contact the distributor from which the dryer was purchased or

American Dryer Corporation

88 Currant Road

Fall River MA 02720-4781

Telephone: (508) 678-9000 / Fax: (508) 678-9447

E-mail: techsupport@amdry.com

Retain This Manual In A Safe Place For Future Reference

American Dryer Corporation products embody advanced concepts in engineering, design, and safety. If this product is properly maintained, it will provide many years of safe, efficient, and trouble-free operation.

ONLY qualified technicians should service this equipment.

OBSERVE ALL SAFETY PRECAUTIONS displayed on the equipment or specified in the installation/operator's manual included with the dryer.

The following "FOR YOUR SAFETY" caution must be posted near the dryer in a prominent location.

FOR YOUR SAFETY

Do not store or use gasoline or other flammable vapors or liquids in the vicinity of this or any other appliance.

POUR VOTRE SÉCURITÉ

Ne pas entreposer ni utiliser d'essence ni d'autres vapeurs ou liquides inflammables dans le voisinage de cet appareil ou de tout autre appareil.

We have tried to make this manual as complete as possible and hope you will find it useful. ADC reserves the right to make changes from time to time, without notice or obligation, in prices, specifications, colors, and material, and to change or discontinue models.

Important

For your convenience, log the following information:

DATE OF PURCHASE _____ MODEL NO. **AD-385** _____

DISTRIBUTORS NAME _____

Serial Number(s) _____

Replacement parts can be obtained from your distributor or the ADC factory. When ordering replacement parts from the factory, you can FAX your order to ADC at (508) 678-9447 or telephone your orders directly to the ADC Parts Department at (508) 678-9000. Please specify the dryer **model number** and **serial number** in addition to the **description** and **part number**, so that your order is processed accurately and promptly.

The illustrations on the following pages may not depict your particular dryer exactly. The illustrations are a composite of the various dryer models. Be sure to check the descriptions of the parts thoroughly before ordering.

"IMPORTANT NOTE TO PURCHASER"

Information must be obtained from your local gas supplier on the instructions to be followed if the user smells gas. These instructions must be posted in a prominent location near the dryer.

IMPORTANT

YOU MUST DISCONNECT and LOCKOUT THE ELECTRIC SUPPLY and THE GAS SUPPLY or THE STEAM SUPPLY BEFORE ANY COVERS or GUARDS ARE REMOVED FROM THE MACHINE TO ALLOW ACCESS FOR CLEANING, ADJUSTING, INSTALLATION, or TESTING OF ANY EQUIPMENT per OSHA (Occupational Safety and Health Administration) STANDARDS.

“Caution: Label all wires prior to disconnection when servicing controls. Wiring errors can cause improper operation.”

«Attention: Lor des opérations d’entretien des commandes étiqueter tous fils avant de les déconnecter. Toute erreur de câblage peut être une source de danger et de panne.»

CAUTION

DRYER(S) SHOULD NEVER BE LEFT UNATTENDED WHILE IN OPERATION.

WARNING

**CHILDREN SHOULD NOT BE ALLOWED TO PLAY ON OR NEAR THE DRYER(S).
CHILDREN SHOULD BE SUPERVISED IF NEAR DRYER(S) IN OPERATION.**

FOR YOUR SAFETY

**DO NOT DRY MOP HEADS IN THE DRYER.
DO NOT USE DRYER IN THE PRESENCE OF DRY CLEANING FUMES.**

WARNING

UNDER NO CIRCUMSTANCES should the door switch or the heat circuit devices ever be disabled.

WARNING

The dryer must never be operated with any of the back guards, outer tops, or service panels removed. PERSONAL INJURY or FIRE COULD RESULT.

WARNING

DRYER MUST NEVER BE OPERATED WITHOUT THE LINT FILTER/SCREEN IN PLACE...EVEN IF AN EXTERNAL LINT COLLECTION SYSTEM IS USED.

IMPORTANT

PLEASE OBSERVE ALL SAFETY PRECAUTIONS displayed on the equipment and/or specified in the installation/operator's manual included with the dryer.

Dryer(s) must not be installed or stored in an area where it will be exposed to water and/or weather.

The wiring diagram for the dryer is located in the front electrical control box area.

Table of Contents

<i>SECTION I</i>	
IMPORTANT INFORMATION	3
A. RECEIVING and HANDLING	3
B. SAFETY PRECAUTIONS	4
<i>SECTION II</i>	
SPECIFICATIONS/COMPONENT IDENTIFICATION	6
A. SPECIFICATIONS	6
<i>SECTION III</i>	
INSTALLATION PROCEDURES	8
A. LOCATION REQUIREMENTS	8
B. UNPACKING/SETTING UP	9
C. DRYER ENCLOSURE REQUIREMENTS	10
D. FRESH AIR SUPPLY	11
E. EXHAUST REQUIREMENTS	13
F. ELECTRICAL INFORMATION	18
G. GAS INFORMATION	23
H. PREPARATION FOR OPERATION/START-UP	26
I. PREOPERATIONAL TESTS	27
J. PREOPERATIONAL INSTRUCTIONS	29
K. SHUT DOWN INSTRUCTIONS	31
<i>SECTION IV</i>	
SERVICE/PARTS INFORMATION	32
A. SERVICE	32
B. PARTS	32

<i>SECTION V</i>	
WARRANTY INFORMATION	33
A. RETURNING WARRANTY CARD(S)	33
B. PARTS	33
C. RETURNING WARRANTY PARTS	33
<i>SECTION VI</i>	
ROUTINE MAINTENANCE	35
A. CLEANING	35
B. ADJUSTMENTS	36
C. LUBRICATION	36
<i>SECTION VII</i>	
TROUBLESHOOTING	37
Microprocessor (Coin) Models	38
Mechanical (Coin) Meter Models	42
(OPL) Microprocessor (Computer) Models	47
Dual Timer (OPL) Models	55
<i>SECTION VIII</i>	
TECHNICAL INFORMATION	60
<i>SECTION IX</i>	
PROCEDURE FOR FUNCTIONAL CHECK OF REPLACEMENT COMPONENTS	62

SECTION I

IMPORTANT INFORMATION

A. RECEIVING and HANDLING

The dryer is shipped in a protective stretch wrap cover with protective cardboard corners and top cover (or optional box) as a means of preventing damage in transit. Upon delivery, the dryer and/or packaging, and wooden skid should be visually inspected for shipping damage. If any damage whatsoever is noticed, inspect further before delivering carrier leaves.

Dryers damaged in shipment.

1. **ALL** dryers should be inspected upon receipt and before they are signed for.
2. If there is suspected damage or actual damage, the trucker's receipt should be so noted.
3. If the dryer is damaged beyond repair, it should be refused. Those dryers which were not damaged in a damaged shipment should be accepted, but the number received and the number refused *must be* noted on the receipt.
4. If you determine that the dryer was damaged after the trucker has left your location, you should call the delivering carrier's freight terminal immediately and file a claim. The freight company considers this concealed damage. This type of freight claim is very difficult to get paid and becomes extremely difficult when more than a day or two passes after the freight was delivered. It is your responsibility to file freight claims. Dryer/parts damaged in transit **cannot** be claimed under warranty.
5. Freight claims are the responsibility of the consignee, and **ALL** claims *must be* filed at the receiving end. ADC assumes no responsibility for freight claims or damages.
6. If you need assistance in handling the situation, please contact the ADC Traffic Manager at (508) 678-9000.

IMPORTANT: The dryer *must be* transported and handled in an upright position at all times.

B. SAFETY PRECAUTIONS

WARNING: For your safety, the information in this manual **must** be followed to minimize the risk of fire or explosion or to prevent property damage, personal injury, or loss of life.

WARNING: The dryer **must never be operated with any of the back guards, outer tops, or service panels removed. PERSONAL INJURY or FIRE COULD RESULT.**

1. **DO NOT** store or use gasoline or other flammable vapors and liquids in the vicinity of this or any other appliance.
2. Purchaser/user should consult the local gas supplier for proper instructions to be followed in the event the user smells gas. The instructions **should** be posted in a prominent location.
3. **WHAT TO DO IF YOU SMELL GAS...**
 - a. **DO NOT** try to light any appliance.
 - b. **DO NOT** touch any electrical switch.
 - c. **DO NOT** use any phone in your building.
 - d. Clear the room, building, or area of **ALL** occupants.
 - e. Immediately call your gas supplier from a neighbor's phone. Follow the gas supplier's instructions.
 - f. If you cannot reach your gas supplier, call the fire department.
4. Installation and service *must be* preformed by a qualified installer, service agency, or gas supplier.
5. Dryer(s) **must** be exhausted to the outdoors.
6. Although ADC produces a very versatile machine, there are some articles that, due to fabric composition or cleaning method, **should not** be dried in it.

WARNING: Dry only water-washed fabrics. **DO NOT** dry articles spotted or washed in dry cleaning solvents, a combustible detergent, or "all purpose" cleaner. **EXPLOSION COULD RESULT.**

WARNING: **DO NOT** dry rags or articles coated or contaminated with gasoline, kerosene, oil, paint, wax. **EXPLOSION COULD RESULT.**

WARNING: **DO NOT** dry mop heads. Contamination by wax or flammable solvents will create a fire hazard.

WARNING: DO NOT use heat for drying articles that contain plastic, foam, sponge rubber, or similarly textured rubber materials. Drying in a heated basket (tumbler) may damage plastics or rubber and also may be a fire hazard.

7. A program should be established for the inspection and cleaning of lint in the heating unit area, exhaust duct work, and inside the dryer. The frequency of inspection and cleaning can best be determined from experience at each location.

WARNING: The collection of lint in the burner area and exhaust duct work can create a potential fire hazard.

8. For personal safety, the dryer *must be* electrically grounded in accordance with local codes and/or the National Electric Code ANSI/NFPA NO. 70-LATEST EDITION.

NOTE: Failure to do so will VOID THE WARRANTY.

9. UNDER NO CIRCUMSTANCES should the dryer door switches, heat safety circuit, ever be disabled.

WARNING: PERSONAL INJURY or FIRE COULD RESULT.

10. This dryer is not to be used in the presence of dry cleaning solvents or fumes.
11. Remove articles from the dryer as soon as the drying cycle has been completed.

WARNING: Articles left in the dryer after the drying and cooling cycles have been completed can create a fire hazard.

12. READ and FOLLOW ALL CAUTION and DIRECTION LABELS ATTACHED TO THE DRYER.

WARNING: YOU MUST DISCONNECT and LOCKOUT THE ELECTRIC SUPPLY and THE GAS SUPPLY BEFORE ANY COVERS or GUARDS ARE REMOVED FROM THE MACHINE TO ALLOW ACCESS FOR CLEANING, ADJUSTING, INSTALLATION, or TESTING OF ANY EQUIPMENT per OSHA (Occupational Safety and Health Administration) STANDARDS.

SECTION II

SPECIFICATIONS/COMPONENT IDENTIFICATION

A. SPECIFICATIONS

MAXIMUM CAPACITY (DRY WEIGHT)		30 lbs.	13.6 kg
BASKET (TUMBLER) DIAMETER		27-1/4"	69.22 cm
BASKET (TUMBLER) DEPTH		30"	76.2 cm
BASKET (TUMBLER) MOTOR		1 HP	.746 kw
DOOR OPENING (DIAMETER)		21-1/2"	54.61 cm
BASKET (TUMBLER) VOLUME		10.12 cu. ft.	.286 cu. m.
DRYERS PER 20'/40' CONTAINER		14/30	
DRYERS PER 45'/48' TRUCK		36/38	
Gas	VOLTAGE AVAILABLE	120-230v / 1 ϕ / 50/60 Hz	
	APPROX. WEIGHT (UNCRATED)	450 lbs.	204 kg
	APPROX. WEIGHT (CRATED)	500 lbs.	227 kg
	HEAT INPUT	110,000 btuh	27,721 kcal/hr
	AIRFLOW	750 cfm	21.22 cmm
	INLET PIPE CONNECTION	3/4"	1.91 cm

Shaded areas are in metric equivalents

NOTE: ADC reserves the right to make changes in specifications at any time without notice or obligation.

Specifications

ADG-385

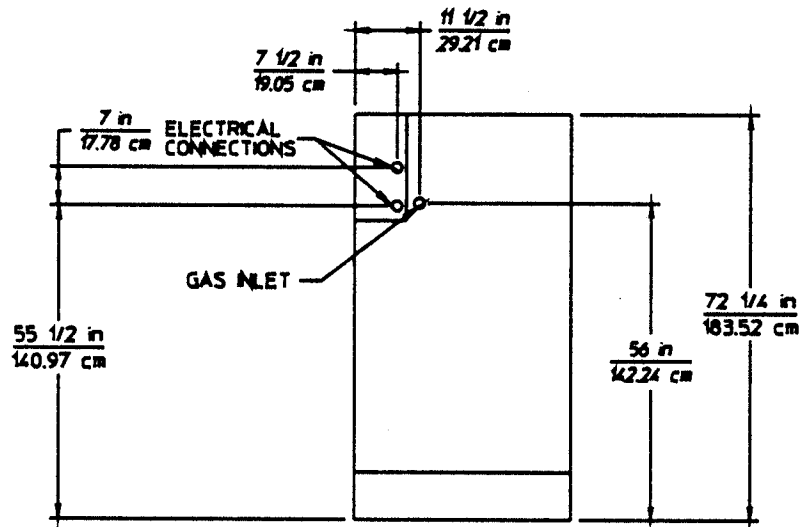

REAR VIEW

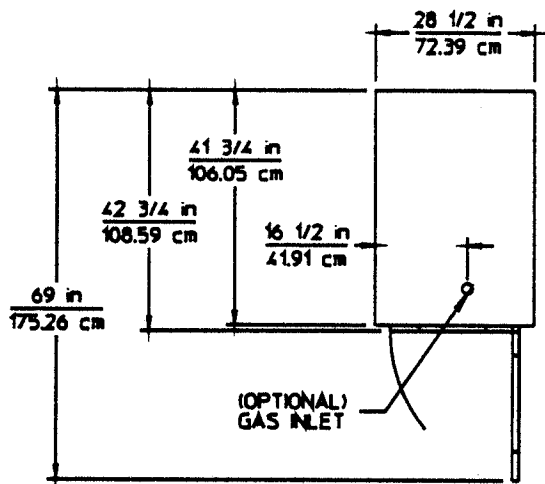

PLAN VIEW

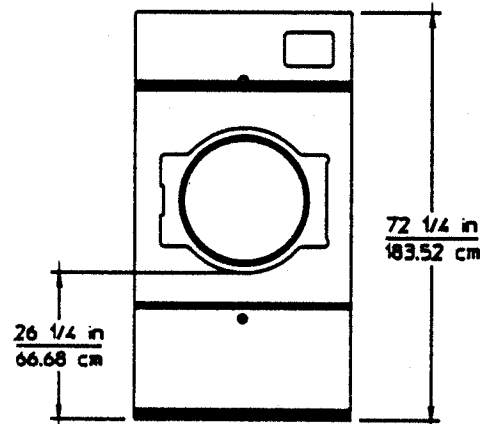

FRONT VIEW

SPEC 161

SECTION III

INSTALLATION PROCEDURES

Installation should be performed by competent technicians in accordance with local and state codes. In the absence of these codes, the installation **must conform** to applicable American National Standards: National Fuel Gas Code ANSI.Z223.1-LATEST EDITION and/or National Electric Code ANSI/NFPA NO. 70-LATEST EDITION.

A. LOCATION REQUIREMENTS

Before installing the dryer, be sure the location conforms to local codes and ordinances. In the absence of such codes or ordinances the location **must conform** with the National Fuel Gas Code ANSI.Z223.1-LATEST EDITION.

1. The dryer **must be** installed on a sound level floor capable of supporting its weight. It is recommended that carpeting be removed from the floor area that the dryer is to rest on.
2. The dryer **must not be** installed or stored in an area where it will be exposed to water and/or weather.
3. Provisions for adequate air supply **must be** provided as noted in this manual (refer to **Fresh Air Supply** in Section D).
4. Clearance provisions **must be** made from combustible construction as noted in this manual (refer to **Dryer Enclosure Requirements** in Section C).
5. Provisions **must be** made for adequate clearances for servicing and for operation as noted in this manual (refer to **Dryer Enclosure Requirements** in Section C).
6. Dryer **must be** exhausted to the outdoors (refer to **Exhaust Requirements** in Section E).
7. Dryer **must be** located in an area where correct exhaust venting can be achieved as noted in the manual (refer to **Exhaust Requirements** in Section E).

IMPORTANT: Dryer should be located where a minimum amount of exhaust duct will be necessary.

B. UNPACKING/SETTING UP

Remove protective shipping material (i.e., plastic wrap, and/or optional shipping box) from dryer.

LOCKS/KEYS

Coin Models: The access keys to the control (service) door, and lint door are included inside the information package shipped in the dryer tumbler (basket) and should be removed and put in a safe place. The keys should be made accessible because they will be needed throughout various phases in the installation of the unit.

OPL Models: For models equipped with locks, the lock used is a dummy lock and no key is supplied or needed. The lock can be turned with any key, a screwdriver, a small coin, or any small sharp object.

The dryer can be moved to its final location while still attached to the skid or with the skid removed. To un-skid the dryer, locate and remove the four (4) bolts securing the base of the dryer to the wooden skid. Two (2) are at the rear base (remove the back panel for access), and two (2) are located in the bottom of the lint chamber. To remove the two (2) bolts located in the lint chamber area, remove the lint door.

With the skid removed, to make it easier to slide the dryer into its final position, slightly lower **ALL** four (4) leveling legs, so that the dryer will slide on the legs instead of the base frame.

To increase bearing life and improve efficiency, and for better automatic closure of the main door the dryer **should** be tilted slightly to the rear.

C. DRYER ENCLOSURE REQUIREMENTS

Bulkheads and partitions **should be** made of noncombustible materials and **must be** located a minimum of twelve (12) inches (18-inches or more is recommended for ease of installation, maintenance, and service) above the dryer outer top, except along the front of the dryer which may be partially closed in if desired.

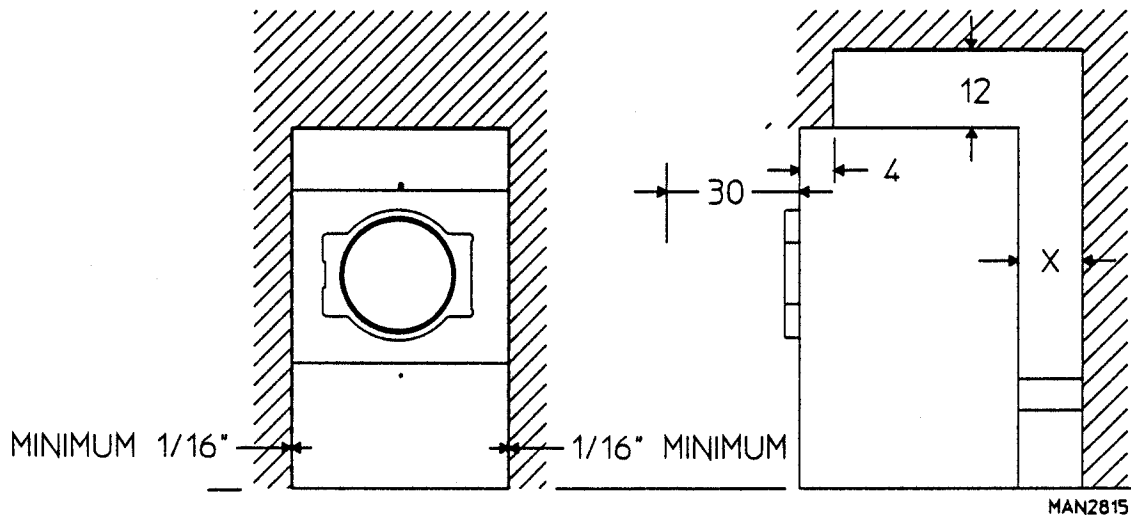

X= 12", 24" is recommended for ease of maintenance.

NOTE: Allowances **must be** made for opening the control door.

Dryers may be positioned side wall to side wall. However, a 1/16" minimum allowance **must be** made for opening and closing of the control door and the lint door. It is suggested that the dryer be positioned about two (2) feet away from the nearest obstruction for ease of installation, maintenance, and service (to be measured from the back guard). Refer to the **illustration** above for details.

NOTE: Air considerations are important for proper and efficient operation.

D. FRESH AIR SUPPLY

When the dryer is operating, it draws in room air, heats it, passes this air through the basket (tumbler), and exhausts it out of the building. Therefore, the room air **must be continually** replenished from the outdoors. If the make-up air is inadequate, drying time and drying efficiency will be adversely affected. Ignition problems and sail switch "fluttering" problems may result, as well as premature motor failure from overheating.

Air supply (make-up air) **must be** given careful consideration to assure proper performance of each dryer. An unrestricted source of air is necessary for each dryer. As a general rule, an unrestricted air entrance from the outdoors (atmosphere) of a minimum of 1-1/2 square feet is required for each dryer. To compensate for the use of registers or louvers used over the openings, this make-up air **must be** increased by approximately thirty-three percent (33%). It is not necessary to have a separate make-up air opening for each dryer. Common make-up air openings are acceptable. However, they **must be** set up in such a manner that the make-up air is distributed equally to ALL the dryers.

EXAMPLE: For a bank of four (8) dryers, two (2) unrestricted openings measuring 2 feet by 3 feet (6 square feet each) is acceptable.

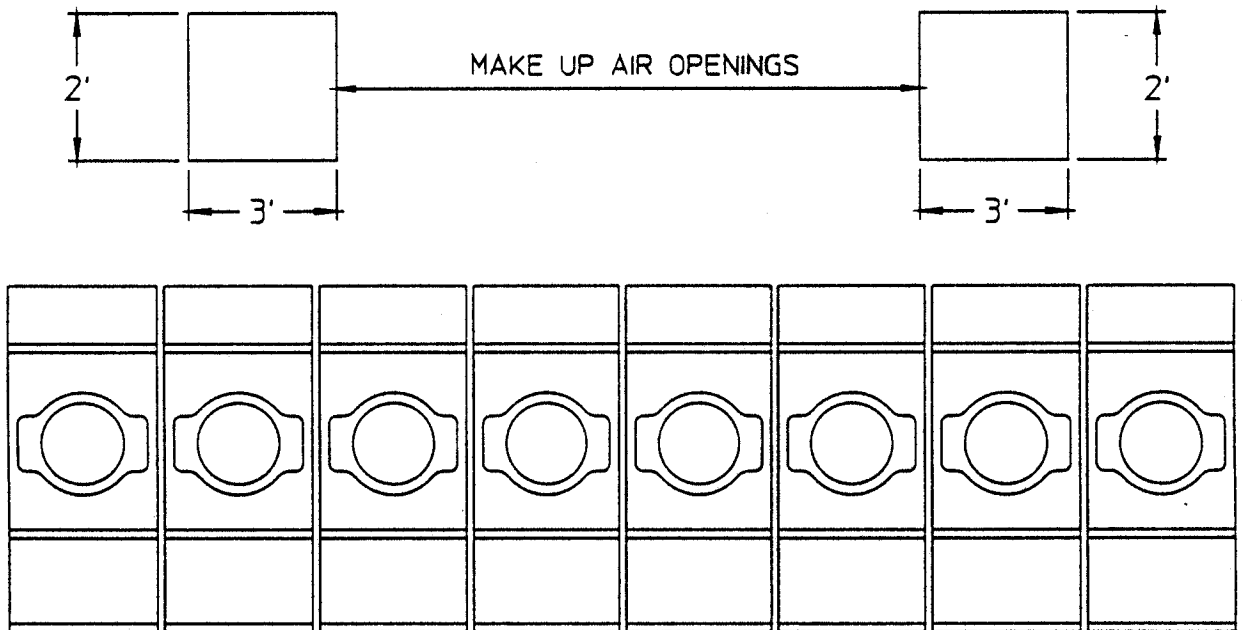

MAN1779

TYPICAL INSTALLATION SHOWING MAKE - UP AIR OPENINGS

NOTE: Make-up air openings *should not be* located in an area directly near where exhaust vents exit the building.

Allowances **must be** made for remote or constricting passageways or where dryers are located at excessive altitudes or predominantly low pressure areas.

IMPORTANT: Make-up air **must be** provided from a source free of dry cleaning solvents fumes. Make-up air that is contaminated by dry cleaning solvent fumes will result in irreparable damage the motors and other dryer components.

NOTE: Component failure due to dry cleaning solvent fumes will VOID THE WARRANTY.

E. EXHAUST REQUIREMENTS

Exhaust duct work should be designed and installed by a qualified professional. Improperly sized duct work will create excessive back pressure which results in slow drying, increased use of energy, overheating of the dryer, and shutdown of the burner by the airflow (sail) switches, burner hi-limits, or basket (tumbler) hi-heat thermostats.

CAUTION: DRYER MUST BE EXHAUSTED TO THE OUTDOORS.

CAUTION: IMPROPERLY SIZED OR INSTALLED EXHAUST DUCT WORK CAN CREATE A POTENTIAL FIRE HAZARD.

The duct work should be laid out in such a way that the duct work travels as directly as possible to the outdoors with as few turns as possible. Single or independent dryer venting is recommended.

The dryer is manufactured with an 8" exhaust duct outlet. When single drying venting is used an 8" exhaust duct can be used providing that the duct work from the dryer to the outside exhaust outlet does not exceed ten (10) feet and there is no more than one (1) elbow (which is the outside exhaust outlet protection). See illustration A on page 14 for details. For exhaust ducting which exceeds ten (10) feet, the minimum diameter of this duct must be at least 10 inches (even though the dryer exhaust duct outlet is only 8"). See illustrations B and C on page 15 for examples. In the case of multiple (common) dryer venting, the distance from the last dryer to the outside exhaust duct outlet should not exceed twenty (20) feet. The shape of the duct work is not critical so long as the minimum cross-sectional area is provided. It is suggested that the use of 90 degree turns be avoided; use 30 degree and/or 45 degree angles instead. The radius of the elbows should preferably be 1-1/2 times the diameter of the duct. Including basket (tumbler)/dryer elbow connections or elbows used for outside protection from the weather, no more than two (2) elbows should be used in the exhaust run. If more than two (2) elbows are used, the cross sectional area of the duct work must be increased.

ALL duct work should be smooth inside with no projections from sheet metal screws or other obstructions which will collect lint. When adding ducts, the duct to be added should overlap the duct to which it is to be connected. ALL duct work joints **must be taped** to prevent moisture and lint from escaping into the building. Inspection door should be installed at strategic points in the exhaust duct work for periodic inspection and clean-out of lint from the duct work.

IMPORTANT: Exhaust back pressure measured by a manometer in the exhaust duct should not exceed 0.3 inches of water column.

IMPORTANT: For exhaust runs over 10 feet, minimum duct work diameter is 10-inches.

NOTE: Where the exhaust duct work passes through a wall, ceiling, or roof made of combustible materials, the opening must be 2-inches larger (all the way around) than the duct. The duct must be centered within this opening.

To protect the outside end of horizontal duct work from the weather, a 90° elbow bent downward should be installed where the exhaust exits the building. If the duct work travels vertically up through the roof, it should be protected from the weather by using a 180° turn to point the opening downward. In either case, allow at least twice the diameter of the duct between the duct opening and the nearest obstruction.

IMPORTANT: DO NOT use screens or caps on the outside of opening of exhaust duct work.

IMPORTANT: Exhaust back pressure measured by a manometer at each basket (tumbler) exhaust duct area *should not* exceed 0.3 inches of water column.

SINGLE DRYER VENTING

IMPORTANT: For exhaust duct runs of over 10 feet a minimum duct size of 10-inches must be used.

When single 8-inch venting is used, the duct work from the dryer to the outside outlet cannot exceed 10 feet (refer to Illus. A below). This calculation of 10 feet compensates or allows for the use of a maximum of only one (1) elbow (which is the outside outlet protection).

Illus. A.

HORIZONTAL SINGLE DRYER VENTING 8 INCH DUCTING

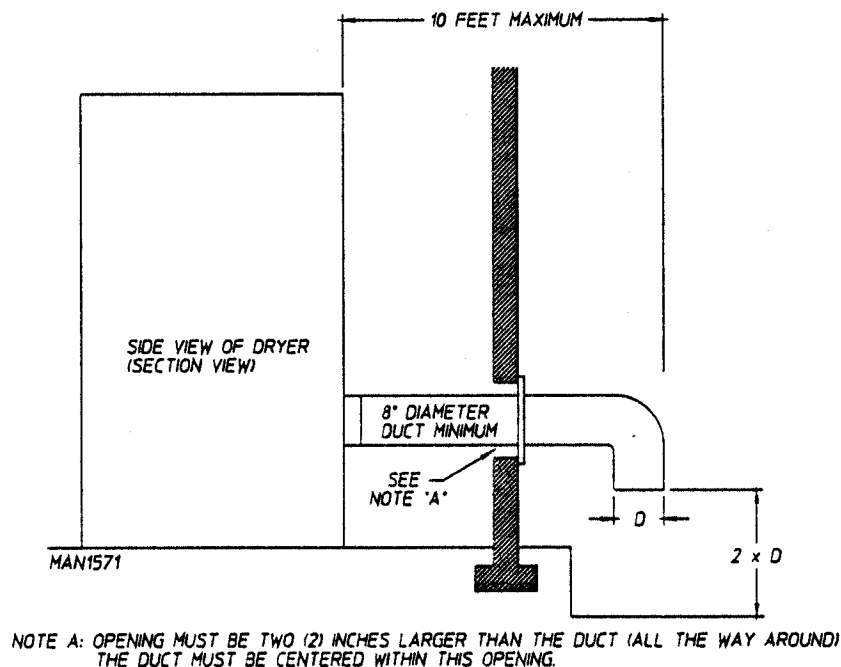

When single 10-inch vertical venting is used (refer to Illus. B. below), the duct work from the dryer to the outside outlet cannot exceed 20 feet. This calculation of 20 feet compensates or allows for the use of a maximum of only two (2) elbows creating the 180° (turned downward) outside outlet.

Illus. B.

VERTICAL SINGLE DRYER VENTING

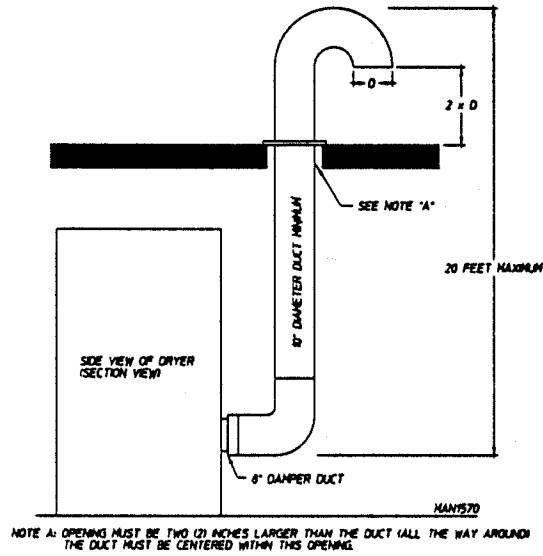

For a 10-inch horizontal run where a maximum of one (1) elbow is used (refer to Illus. C below); the duct work from the dryer outlet should not exceed 50 feet. A 10-inch horizontal duct where (3) elbows (including outside outlet protection) are used cannot exceed 30 feet in length.

Illus. C.

HORIZONTAL SINGLE DRYER VENTING 10 INCH DUCTING

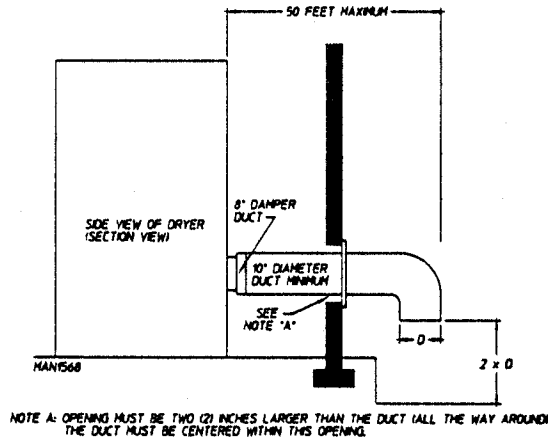

If the length of the duct run or quantity of elbows used exceeds the above noted specifications, the cross area of the duct work **must be** increased in proportion to the number of elbows or duct run added.

IMPORTANT: For extended duct work runs, the cross section area of the duct work can only be increased to an extent. When the duct work approaches the maximum limits noted in this manual, a professional heating venting air conditioning (HVAC) firm **should be** consulted for proper venting information.

MULTIPLE DRYER (Common) VENTING

If it is not feasible to provide separate exhaust ducts for each dryer, ducts from individual dryers may be channeled into a "common main duct." The individual ducts should enter the bottom or side of the main duct at an angle not more than 45° in the direction of air flow and should be spaced at least 28-1/2 inches apart. The main duct should be tapered, with the diameter increasing before each individual duct (10-inch minimum) is added.

The main duct may be any shape so long as the minimum cross section is provided. The main duct should be tapered with the diameter increasing before each individual 10-inch duct is added (refer to Illus. D below).

Illus. D.

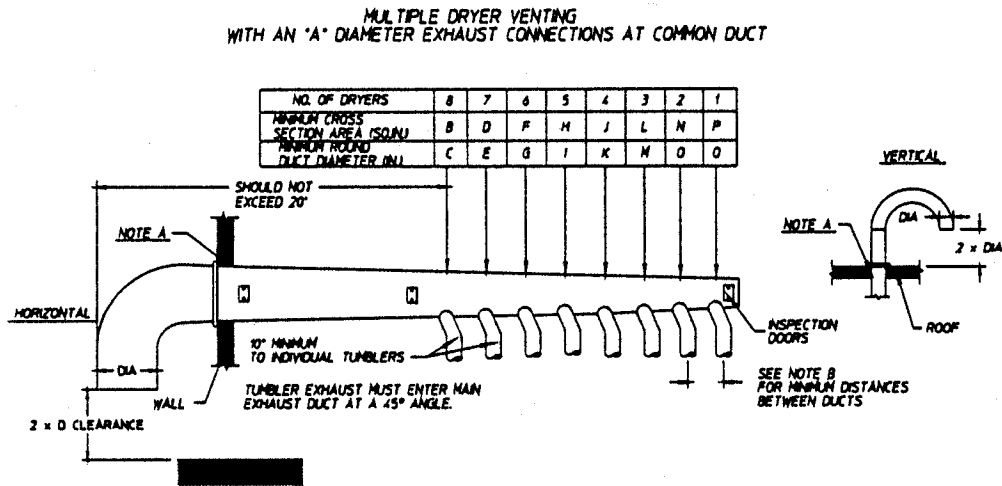

IMPORTANT: NO MORE THAN 8 DRYERS CAN BE CONNECTED TO ONE COMMON DUCT (VENT) WITH A HORIZONTAL RUN AND NO MORE THAN 6 DRYERS CAN BE CONNECTED WITH A VERTICAL RUN.

NOTE A: OPENING MUST BE TWO (2) INCHES LARGER THAN DUCT (ALL THE WAY AROUND). THE DUCT MUST BE CENTERED WITHIN THIS OPENING.

NOTE B: AD-385 28 1/2" WIDE 750 CFM

HL 12/06/93

MAN2818

B=400	F=324	J=256	N=164
C=22	G=20	K=18	O=14
D=324	H=256	L=210	P=80
E=20	I=18	M=16	Q=10

The maximum length of venting from the last dryer to where it exhausts...

Vertical venting run must not exceed 20 feet. This calculation compensates for the use of a maximum of three (3) elbows including the two (2) elbows creating 180° (turned downward) outside outlet.

IMPORTANT: No more than six (6) dryers maximum should be converted to one (1) main common duct with a vertical run.

Horizontal venting must not exceed 20 feet. This calculation compensates for the use of a maximum of only one (1) elbow which is the outside outlet protection.

IMPORTANT: No more than eight (8) dryers maximum should be converted to one (1) main common duct with a horizontal run.

NOTE: Distance between dryer single ducts being connected to the main common duct must be a minimum of 28-1/2" (dryer width).

Duct work should be laid out in such in a manner where allowances are made at rear area of dryer for removal of rear service panels/guards.

Illustration D (refer to page 16) shows the minimum cross-section area for multiple dryer venting. These figures must be increased in proportion if the main duct run from the last dryer to where it exhausts has numerous elbows or is unusually long.

IMPORTANT: For extended duct work runs, the cross section area of the duct work can only be increased to an extent. When the duct work approaches the maximum limits as noted in this manual, a professional HVAC firm should be consulted for proper venting HVAC from should be consulted for proper venting information.

IMPORTANT VENTING REMINDERS

1. Duct work size and installation should be done by a qualified professional.
2. The dryer **must be** exhausted to the outdoors.
3. Duct work **should be** routed as short as possible to the outdoors with as few elbows as possible.
4. Avoid 90° turns ... use 30° or 45° turns instead.
5. The size of the duct work **must be a minimum** of 10-inches if the exhaust length exceeds 10 feet.
6. The inside of the duct work **should be** as smooth as possible ... with no projections from sheet metal screws.

Ducts added should overlap the duct to which it is to be connected.

7. ALL ducts **should be** taped to prevent moisture and lint from escaping into the building.
8. Inspection/clean out doors should be installed throughout strategic points in the duct work for periodic inspection and cleaning.
9. Wherever the duct passes throughout combustible materials, the opening must be 2-inches larger (all the way around) than the duct. The duct must be centered within this opening.

10. The outside of the duct work must be protected from the weather. A 90° elbow must be used for a horizontal run and when vertically through a roof by using a 180° turn to point the opening downward. Distance between the exhaust duct and the nearest obstruction (i.e., roof or ground) must be twice the diameter of the duct.
11. DO NOT use screens or caps on the outside opening of the exhaust duct work.
12. Exhaust back pressure measured by a manometer at the dryer exhaust duct area must not exceed 0.3 inches of water column.
13. When common ducting is used, the duct work connection between each dryer and the common duct must be 10 inches.

F. ELECTRICAL INFORMATION

1. ELECTRICAL REQUIREMENTS

It is your responsibility to have all electrical connections made by a properly licensed and competent electrician to assure that the electrical installation is adequate and conforms with local and state regulations or codes. In the absence of such codes, ALL electrical connections, material, and workmanship must conform to the applicable requirements of the National Electrical Code ANSI/NFPA NO.70-LATEST EDITION..

IMPORTANT: Failure to comply with these codes or ordinances, and / or the requirements stipulated in this manual can result in personal injury or component failure.

NOTE: Component failure due to improper installation will **VOID THE WARRANTY.**

Each dryer should be connected to an independently protected branch circuit. The dryer must be connected with copper wire only. Do not use aluminum wire which could cause a fire hazard. The copper conductor wire/cable must be of proper ampacity and insulation in accordance with electric codes for making all service connections.

NOTE: The use of aluminum wire will **VOID THE WARRANTY.**

IMPORTANT: Grounding, must conform to applicable requirements of the national electric code.

2. ELECTRICAL SERVICE SPECIFICATIONS

a. Electric service

IMPORTANT: The dryer must be connected to the electrical supply shown on the data label affixed to the dryer. In the case of 208 VAC or 240 VAC, the supply voltage must match the electric service specifications of the data label exactly.

WARNING: 208 VAC and 240 VAC ARE NOT THE SAME. Any damage done to dryer components due to improper voltage connections will automatically VOID THE WARRANTY.

NOTE: On gas dryers, to convert from 208 VAC to 240 VAC (or vice versa), the Direct Spark Ignition (DSI) transformer wiring must be changed.

b. Grounding

A ground (earth) connection must be provided and installed in accordance with state and local codes. In the absence of these codes, grounding must conform to applicable requirements of the NATIONAL ELECTRIC CODE (ANSI/NFPA NO. 70-LATEST EDITION). The ground connection may be to a proven earth ground at the location service panel.

IMPORTANT: The dryer must be grounded. A ground lug has been provided in the service box for this purpose.

For added personal safety, when possible, it is suggested that a separate ground wire (no. 18 minimum) be connected from the ground connection of the dryer to a grounded cold water pipe. DO NOT ground to a gas pipe or hot water pipe. The grounded cold water pipe must have metal to metal connection all the way to electrical ground. If there are any nonmetallic interruptions, such as, a meter, pump, plastic, rubber, or other insulating connectors, they must be jumped with no. 4 copper wire and securely clamped to bare metal at both ends.

IMPORTANT: For personal safety and proper operation, the dryer must be grounded.

c. Electrical Connections

Electrical connections are made at motor contactor (1 phase models) or the power distribution block in the service box at the rear, upper left corner of the dryer. To gain access into the service box the service box cover must be removed.

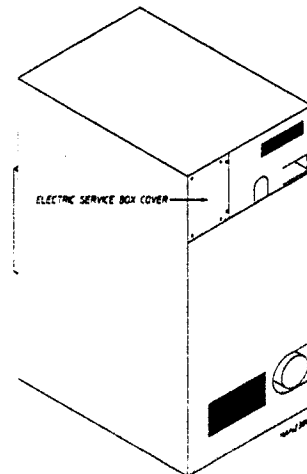

Providing local codes permit, power to the dryer can be made by the use of a flexible U.L. listed cord/pigtail (wire size must conform to the rating of the dryer), or the dryer can be hard wired directly to the service breaker. In ALL cases, a strain relief must be used where the wiring enters the dryer and the service box.

A wire diagram is located inside the control box area for connections data.

1.) Single Phase (1 0) Model (Hookup) Connections

The electrical input connections to the dryer the two (2) power lead connections (L1 and N or L2) and the ground.

SINGLE PHASE (10) ELECTRICAL CONNECTIONS

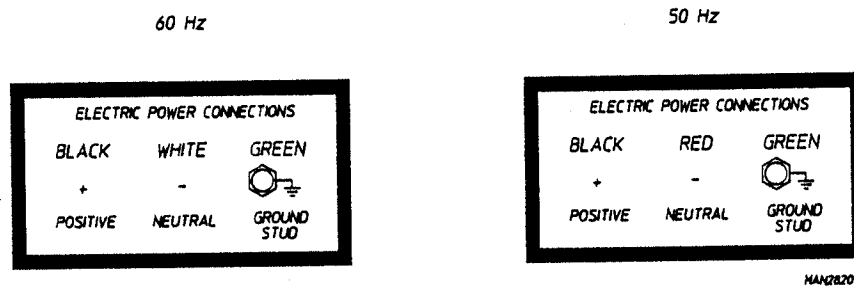

The two (2) power connections are made at the motor contactor (L1 and L2 termination points) located inside the electrical service box. The ground connection is made at the ground lug also provided in this service box.

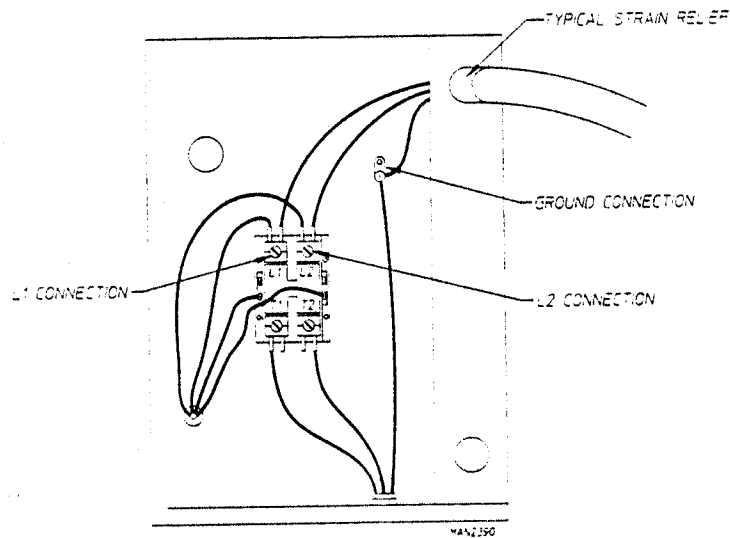

Providing local codes permit, power to the dryer can be made by the use of a flexible U.L. listed cord/pigtail, or the dryer can be hard wired directly to the service breaker. In ALL cases, a strain relief must be used where the wiring enters the dryer and service box.

IMPORTANT: Input connection wiring must be sized properly to handle the dryer's current draw. This current/amperage information is printed on the dryers data label.

2.) Three Phase (3 Ø) Model (Hookup) Connections

The only electrical input connections to the dryer are the 3-phase (3 Ø) power leads (L1,L2,L3) and ground.

These connections are made at the power distribution block located inside the electric service box. The ground connection is made at the ground lug also provided in this service box.

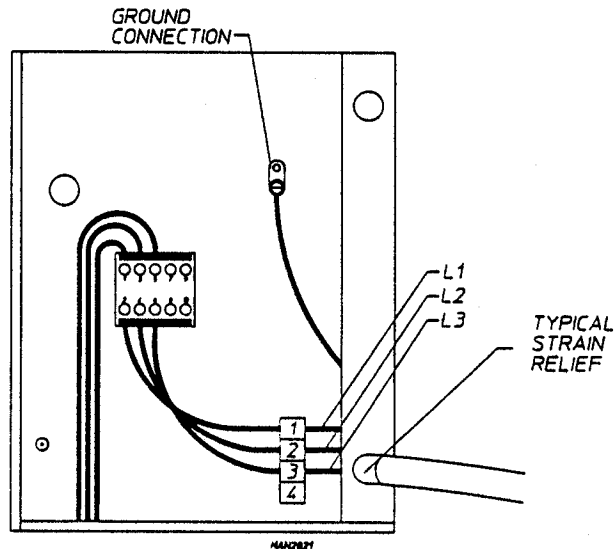

Providing local codes permit, power to the dryer can be made by the use of a flexible U.L. listed cord/pigtail, or the dryer can be hard wired directly to the service breaker. In ALL cases, a strain relief must be used where the wiring enters the dryer and service box.

IMPORTANT: Input connection wiring must be sized properly to handle the dryer's current draw. This current/amperage information is printed on the dryers data label.

NOTES: A. Fuse ratings (as listed in chart on page xx) are dual element-time delay-current limiting, class RK1 or RK5 only.

B. Circuit breakers are thermal magnetic (industrial) type ONLY. For others, calculate/verify correct breaker size according to appliance amp draw rating and type of breaker used.

C. Circuit breakers for 3 Ø dryers must be 3-pole type.

D. Electrical Amperage and Fusing Listing

ADG-385 (Gas*)

ELECTRICAL SERVICE SPECIFICATIONS (PER DRYER)

SERVICE VOLTAGE	PHASE	WIRE SERVICE	APPROX. AMP DRAW	FUSING	CIRCUIT BREAKER
				Dual Element Time Delay	
120	1Ø	2	13	20	25
208	1Ø	2	8	12	15
208	3Ø	3	4.5	6.25	15
230	1Ø	2	7	12	15
230	3Ø	3	4.5	6.25	15

* Figures shown are for voltages @ 60 Hz.

NOTE: Contact factory for electrical information not listed.

NOTE: ADC reserves the right to make changes in specifications at any time, without notice or obligation.

G. GAS INFORMATION

It is your responsibility to have **ALL** plumbing connections made by a qualified professional to assure that the gas plumbing installation is adequate and conforms with local and state regulations or codes. In the absence of such codes, **ALL** plumbing connections, materials, and workmanship **must conform** to the applicable requirements of the National Fuel Gas Code ANSI Z223.1-LATEST EDITION.

IMPORTANT: Failure to comply with these codes or ordinances, and/or the requirements stipulated in this manual, can result in personal injury and improper operation of the dryer.

The dryer and its individual shut-off valves **must be** disconnected from the gas supply piping system during any pressure testing of that system at test pressures in excess of 1/2 psig (3.5 kPa). The dryer **must be** isolated from the gas supply piping system by closing its individual manual shut-off valve during any pressure test of the gas supply system at test pressures equal to or less than 1/2 psig (3.5 kPa).

IMPORTANT: Failure to isolate or disconnect dryer from supply as noted can cause irreparable damage to the gas valve VOIDING THE WARRANTY.

WARNING: FIRE or EXPLOSION COULD RESULT.

1. Gas Supply

The gas dryer installation **must meet** the American National Standard...National Fuel Gas Code ANSI Z223.1-LATEST EDITION, as well as local codes and ordinances and **must be** done by a qualified professional.

NOTE: Undersized gas piping will result in ignition problems, slow drying, increased use of energy, and can create a safety hazard.

The dryer **must be** connected to the type of heat/gas indicated on the dryer label affixed behind the right control box door. If this information does not agree with the type of gas available, **DO NOT operate the dryer** Contact the distributor who sold the dryer or the ADC factory.

IMPORTANT: Any burner changes or conversions **must be** made by a qualified professional.

The input ratings shown on the dryer data label are for elevations up to 2,000 feet, unless elevation requirements of over 2,000 feet were specified at the time the dryer order was placed with the factory. The adjustment or conversion of dryers in the field for elevations over 2,000 feet are made by changing each burner orifice. If this conversion is necessary, contact the distributor who sold the dryer or contact the ADC factory.

2. TECHNICAL GAS DATA

a. Gas Specifications

The natural gas supply pressure to the dryer *must be* between 6 and 12 inches water column. If the pressure is too low, ignition failure and/or slow drying times may result. Excessively high supply pressure will result in erratic operation of the gas valve's internal pressure regulator. The pressure measured at the pressure tap on the body of the gas valve must be 4-inches water column.

b. Liquid Petroleum (L.P.) Gas

Dryers made for use with L.P. gas have the gas valve pressure regulator blocked open, so that the gas pressure *must be* regulated upstream of the dryer. The pressure measured at the gas valve body pressure tap *must be* 11-inches water column. There is no regulator provided on an L.P. dryer. The water column pressure *must be* regulated at the source (L.P. tank), or an external regulator *must be* added to each dryer.

3. Piping/Connections

The dryer is provided with a 3/4" N.P.T. inlet pipe connection extending out the rear or through the top of the dryer. For ease of servicing, the gas supply line of each dryer should have its own shut-off valve.

IMPORTANT: The gas pipe supply line to each dryer must be a minimum of 3/4". DO NOT REDUCE THIS PIPE SIZE REQUIREMENT.

The size of the gas supply line (header) will vary depending on the distance this supply line travels from the gas meter or, in the case of L.P. gas, the supply tank, the number of tees, other gas-operated appliances, etc. Specific information regarding supply line size *should be* determined by the gas supplier.

NOTE: Undersized gas supply piping can create a low or inconsistent gas pressure which will result in erratic operation of the burner ignition system.

Consistent gas pressure is essential at ALL gas connections. It is recommended that a 2-inch pipe gas loop be installed in the supply line serving a bank of dryers. An in-line pressure regulator *must be* installed in the gas supply line (header) if the (natural) gas pressure exceeds 12.0 inches of water column pressure.

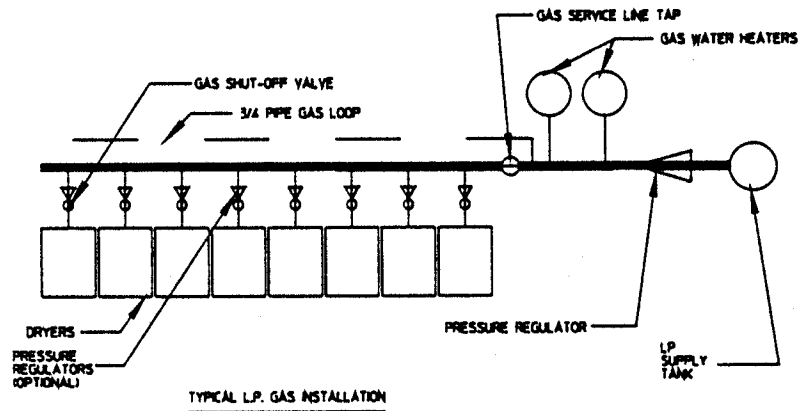
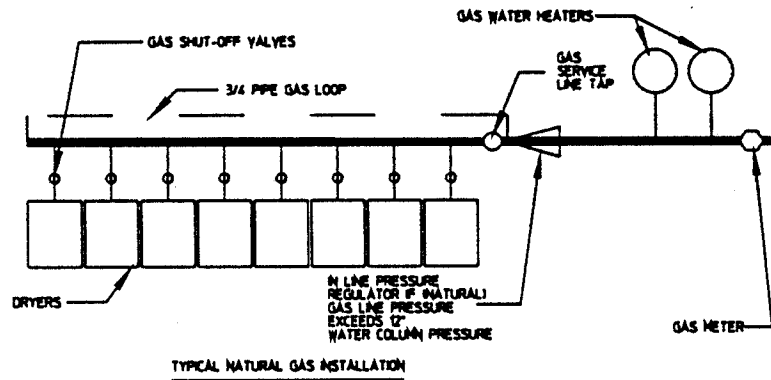

HAN2824

NOTE: A water column test pressure of 3.5-4.0 inches for natural gas and 10.5 to 11.0 inches for L.P. (liquid propane) dryers is required at the gas valve pressure tap of each dryer for proper and safe operation.

A 1/8" N.P.T. plugged tap, accessible for a test gauge connection, **must** be installed in the main gas supply line immediately upstream of each dryer.

IMPORTANT: Pipe joint compounds that resist the action of natural gas and L.P. gas **must** be used.

IMPORTANT: Test **ALL** connections for leaks by brushing on a soapy water solution (liquid detergent works well).

WARNING: NEVER TEST FOR LEAKS WITH A FLAME!!!

ALL components/materials **must conform** to National Gas Code specifications. It is important that gas pressure regulators meet applicable pressure requirements and that gas meters be rated for the total amount of **ALL** the appliance BTU's being supplied.

IMPORTANT: The dryer and its individual shut-off valve **must be disconnected** from the gas supply piping system during any pressure testing of that system at test pressures in excess of 1/2 psig (3.5 kPa).

NOTE: The dryer **must be isolated** from the gas supply piping system by closing its individual manual shut-off valve during any pressure test of the gas supply system at test pressures equal to or less than 1/2 psig (3.5 kPa).

H. PREPARATION FOR OPERATION/START-UP

The following items **should be checked** before attempting to operate the dryer:

1. Read **ALL** "CAUTION," "WARNING," and "DIRECTION" labels attached to the dryer.
2. Check incoming supply voltage to be sure that it is the same as indicated on the dryer data label located on the back of the dryer control (service) door.
3. Check to assure that the dryer is connected to the type of heat/gas indicated on the dryer data label.
4. The sail switch damper assembly was installed and adjusted at the factory prior to shipping. However, each sail switch adjustment **must be** checked to assure that this important safety control is functioning.
5. Check bolts, nuts, screws, terminals, and fittings for tightness.
6. Be sure **ALL** gas shut-off valves are in the open position (for GAS MODELS ONLY).
7. Be sure **ALL** back guard panels and service box covers have been replaced.
8. Check the lint door to assure that it is closed and secured in place.

IMPORTANT: If during installation the lint door safety chain was disconnected, it must be reconnected or personal injury may result.

9. Rotate the basket (tumbler) by hand to be sure it moves freely.

I. PREOPERATIONAL TESTS

ALL dryers are thoroughly tested and inspected before leaving the factory. However, a preoperational test should be performed before the dryer is publicly used. It is possible that adjustments have changed in transit or due to marginal location (installation) conditions.

1. Turn on electric power to the dryer.
2. Refer to the Operating Instructions for starting your particular model dryer.
3. *Gas Dryers*
 - a. When a gas dryer is first started (during initial start-up), it has a tendency not to ignite on the first ignition attempt. This is because the gas supply piping is filled with air, so it may take a few minutes for the air to be purged from the lines.

NOTE: During the purging period, check to be sure that ALL gas shut-off valves are open.

NOTE: Gas dryers are equipped with a direct spark Ignition (DSI) system which has internal diagnostics. If ignition is not established the heat circuit in the DSI module will lock out until it is manually reset. To reset the DSI system, open and close the main door and restart the dryer.

- b. A gas pressure test should be taken at the gas valve pressure tap of each dryer to assure that the water column pressure is correct and consistent.

NOTE: Water column pressure requirements (measured at the pressure tap of the gas valve body):

Natural Gas3.5 - 4.0 -Inches Water Column
L.P. Gas10.5 - 11.0 Inches Water Column

IMPORTANT: There is no regulator provided in an L.P. dryer. The water column pressure must be regulated at the source (L.P. tank), or an external regulator must be added to each dryer.

4. Make a complete operational check of ALL safety related circuits:

- a. Door Switch(es)
- b. Hi-Limit thermostats
- c. Cycling Thermostats
- d. Sail Switch

NOTE: The sail switch can be checked for proper operation by opening the lint door while the heating circuit (gas) is active (on). The heating unit should shut off within a few seconds. If not, make necessary adjustments to sail switch.

5. Make a complete operational check of *ALL* operating controls.

NOTE: If computer program changes are required, refer to the computer programming section of the manual supplied with the dryer.

6. The dryer *should be* operated through one (1) complete cycle to assure that no further adjustments are necessary and that *ALL* components are functioning properly.

IMPORTANT: The dryer basket (tumbler) is treated with a protective coating. ADC suggests tumbling old clothes or material in the basket (tumbler), using a mild detergent to remove the protective coating.

7. Check the electric service phase sequence (3-phase [3 ϕ] models only). While the dryer is operating, check to see if the blower wheel (impeller/fan) is rotating in the proper direction. Looking from the front, the blower wheel (impeller/fan) should spin in the clockwise direction. If it is, the phasing is correct. If the phasing is incorrect, reverse two (2) of the three (3) leads at connections L1, L2, L3 of the power supply to the dryer.

IMPORTANT: If the blower wheel (impellor/fan) is rotating in the wrong direction, this will not only drastically reduce drying efficiency, but it can also cause premature component failure.

I. PREOPERATIONAL INSTRUCTIONS

COIN MODELS

1. Timed Mode (Microprocessor [Computer] Models)

- a. When turning on power or when no cycle is in progress, the LED display will read "FILL" and/or "Amount to Start".
- b. Insert coin(s). Once correct "Amount to Start" has been inserted, the LED display will read "PUSH".
- c. Select temperature by pushing "HI TEMP", "LO TEMP", or "PERM PRESS". The dryer will start, and the LED display will read the temperature cycle selected and the drying time.
- d. The dryer will continue through the drying and cooling cycles, showing time counting downward.

NOTE: If the door is opened during a cycle, both the heat and motor will stop. However, the microprocessor controller (computer) will continue to count down in time. Continuation of the cycle will resume only after the door has been closed and any one of the three (3) temperature selection buttons is again depressed.

- e. Upon completion of drying and cooling cycles, the tone (buzzer) will sound for five (5) seconds, and the LED display will read "donE", at which time the dryer will shut off.

NOTE: 1. If the anti-wrinkle program is active, the LED display will continue to read "donE", and the microprocessor controller (computer) will proceed through the anti-wrinkle program until the maximum "Active Guard Time" has expired or until the door is opened, whichever comes first. The LED display will read "FILL" and/or "Amount to Start".

2. If the anti-wrinkle program is not active or in use, the LED display will read "FILL" and/or "Amount to Start".

2. Automatic Mode (Microprocessor [Computer] Models)

- a. When turning on power or when no cycle is in progress, the start LED display will read "FILL" and/or "Amount to Start".
- b. Insert coin(s). Once the correct "Amount to Start" has been inserted the LED display will read "PUSH".
- c. Select temperature by pushing "HI TEMP", "LO TEMP", or "PERM PRESS". The dryer will start, the LED display will read the temperature cycle selected, and the drying time portion of the LED display will read "00" and count upward as time elapses.

NOTE: If the door is opened during a cycle, both the heat and motor will stop. However, the microprocessor controller (computer) will continue to count downward in time. Continuation of the cycle will resume only after the door has been closed and any one of the three (3) temperature selection buttons is again depressed.

- d. Once the preprogrammed dryness level and cool down period have been reached or maximum automatic time has expired, the tone (buzzer) will sound for five (5) seconds, and the LED display will read "donE", at which time the dryer will shut off.

NOTE: 1. If the anti-wrinkle program is active, the LED display will continue to read "donE", and the microprocessor controller (computer) will proceed through the anti-wrinkle program until the maximum "Active Guard Time" has expired or until the door is opened, whichever comes first. The LED display will read "FILL" and/or "Amount to Start".

2. If the anti-wrinkle program is not active or in use, the LED display will read "FILL" and/or "Amount to Start".

3. Free Dry Mode (Computer Models)

- a. When turning on power or when no cycle is in progress, the LED display will read "FILL" and/or "FrEE".
- b. Select temperature. The dryer will start, the LED display will read the temperature cycle selected, and the drying time portion of the LED display will read "00" and count upward as the time elapses, or the vended time will count downward, depending on the program parameter setting.

NOTE: If the door is opened during a cycle, both the heat and motor will stop. However, the microprocessor controller (computer) will continue to count the time, either upward or downward, depending on which parameter is programmed. Continuation of the cycle will resume only after the door has been closed and any one of the three (3) temperature selection buttons is again depressed.

- c. Once the preprogrammed dryness level and cool down period has been reached or maximum automatic time has expired, whichever comes first, the tone (buzzer) will sound for five (5) seconds, and the LED display will read "donE", at which time the dryer will shut off.

NOTE: 1. If the anti-wrinkle program is active, the LED display will continue to read "donE", and the microprocessor controller (computer) will proceed through the anti-wrinkle program until the maximum "Active Guard Time" has expired or until the door is opened, whichever comes first. The LED display will read "FILL" and/or "Amount to Start".

2. If the anti-wrinkle program is not active or in use, the LED display will read "FILL" and/or "FrEE".

Non Coin (OPL) Models

1. Mechanical Coin Meter Models

- a. Turn power on to the dryer.
- b. Insert coin(s) - Rotary Meter type ONLY.
- c. Select temperature by using rocker switch and selecting "HI TEMP", "LO TEMP", or "PERM PRESS".
- d. Press "Push To Start" button to start the cycle.
- e. Upon completion of the drying and cooling cycles the dryer will shut off.

NOTE: If the door is opened during a cycle, both the heat and motor will stop. Continuation of the cycle will only resume after the door has been closed, and the "Push to Start" button is pressed.

2. Dual Timer Models

- a. Turn drying timer knob (clockwise) for a time of 20 minutes.
- b. Select "High Temp."
- c. Push "Push To Start" button.
- d. To stop dryer, open the main door.

K. SHUT DOWN INSTRUCTIONS

If the dryer is to be shut down (taken out of service) for period time, the following **MUST BE** performed:

1. Discontinue power to the dryer either at the external disconnect switch or the circuit breaker.
2. Discontinue the gas supply:
 - a. SHUT OFF external gas supply shut off valve.
 - b. SHUT OFF internal gas supply shut off valve.

SECTION IV

SERVICE / PARTS INFORMATION

A. SERVICE

1. Service **must be** performed by a qualified trained technician, service agency, or gas supplier. If service is required, contact the distributor from whom the **ADC** equipment was purchased. If the distributor cannot be contacted or is unknown, contact the **ADC** Service Department for a distributor in your area.

NOTE: When contacting the **ADC** Service Department, be sure to give them the correct **model number** and **serial number** so that your inquiry is handled in an expeditious manner.

B. PARTS

1. Replacement parts **should be** purchased from the distributor from whom the **ADC** equipment was purchased. If the distributor cannot be contacted or is unknown, contact the **ADC** Parts Department for a distributor in your area. Parts may also be purchased directly from the factory by calling the **ADC** Parts Department at (508) 678-9010 or you may FAX in your order at (508) 678-9447.

NOTE: When ordering replacement parts from the **ADC** dealer or the **ADC** factory be sure to give them the correct **model number** and **serial number** so that your parts order can be processed in an expeditious manner.

SECTION V

WARRANTY INFORMATION

A. RETURNING WARRANTY CARD(S)

1. Before any dryer leaves the ADC factory test area, a warranty card (ADC Part No. 112254) is placed on the back side of the main door glass. These warranty cards are intended to serve the customer where we record the individual installation date and warranty information to better serve you, if you file a warranty claim.
 - a. If a warranty card (ADC Part No. 112254) did not come with your dryer, contact the ADC Warranty Department or the ADC Service Department at (508) 678-9000.

B. WARRANTY

For a copy of the ADC commercial warranty covering your particular dryer(s), contact the ADC distributor from whom you purchased the equipment and request dryer warranty form ADC Part No. 450199. If the distributor *cannot* be contacted or is unknown, warranty information can be obtained from the factory by contacting the ADC Warranty Department at (508) 678-9000.

NOTE: Whenever contacting the ADC factory for warranty or warranty information, be sure to have the dryer's **model number** and **serial number** available so that your inquiry can be handled in an expeditious manner.

C. RETURNING WARRANTY PARTS

ALL dryer or parts warranty claims or inquiries **should be** addressed to the ADC Warranty Parts Department. To expedite processing, the following procedures **must be** followed:

1. No parts are to be returned to ADC without prior written authorization ("Return Material Authorization") from the factory.

NOTE: An R.M.A. ("Return Material Authorization") is valid for only sixty (60) days from date of issue.

- a. The R.M.A. issued by the factory, as well as any other correspondence pertaining to the returned part(s), **must be** included inside the package with the failed merchandise.
2. Each part **must be** tagged with the following information:
 - a. **Model number** and **serial number** of the dryer from which part was removed.
 - b. Nature of failure (be specific).
 - c. Date of dryer installation.
 - d. Date of part failure.

e. Specify whether the part(s) being returned is for a replacement, a credit, or a refund.

NOTE: If a part is marked for a credit or a refund, the invoice number covering the purchase of the replacement part **must be provided**.

NOTE: Warranty tags (ADC Part No. 450064) are available at "no charge" from ADC upon request.

3. The company returning the part(s) must clearly note the complete company name and address on the outside of the package.
4. **ALL** returns **must be** properly packaged to insure that they are not damaged in transit. *Damage claims are the responsibility of the shipper.*

IMPORTANT: No replacements, credits or refunds will be issued for merchandise damaged in transit.

5. **ALL** returns **should be** shipped to the ADC factory in such a manner that they are insured and a proof of delivery can be obtained by the sender.
6. **Shipping charges are not the responsibility of ADC. ALL returns should be "prepaid" to the factory. Any "C.O.D." or "COLLECT" returns will not be accepted.**

IMPORTANT: No replacements, credits, or refunds will be issued if the claim *cannot* be processed due to insufficient information. The party filing the claim will be notified in writing, either by "FAX" or "CERTIFIED MAIL - Return Receipt Requested," as to the information necessary to process claim. If a reply is not received by the ADC Warranty Department within thirty (30) days from the FAX/letter date, then no replacement, credit, or refund will be issued, and the merchandise **will be discarded**.

SECTION VI

ROUTINE MAINTENANCE

A. CLEANING

A program and/or schedule **should** be established for periodic inspection, cleaning, and removal of lint from various areas of the dryer, as well as throughout the duct work system. The frequency of cleaning can best be determined from experience at each location. Maximum operating efficiency is dependent upon proper air circulation. The accumulation of lint can restrict this air flow. If the guidelines in this section are met, an ADC dryer will provide many years of efficient, trouble-free, and - most importantly - safe operation.

WARNING: LINT FROM MOST FABRICS IS HIGHLY COMBUSTIBLE. THE ACCUMULATION OF LINT CAN CREATE A POTENTIAL FIRE HAZARD.

WARNING: KEEP DRYER AREA CLEAR AND FREE FROM COMBUSTIBLE MATERIALS, GASOLINE, and OTHER FLAMMABLE VAPORS and LIQUIDS.

NOTE: Suggested time intervals shown are for average usage which is considered six (6) to eight (8) operational (running) hours per day.

SUGGESTED CLEANING SCHEDULE

EVERY THIRD or FOURTH LOAD

Clean the lint screen every third or fourth load. A clogged lint screen will cause poor dryer performance. The lint screen is located behind the lint door in the base of the dryer. Open the lint door, brush the lint off the lint screen, and remove the lint. Inspect lint screen and replace if torn.

NOTE: The frequency of cleaning the lint screen can best be determined from experience at each location.

WEEKLY

Clean lint accumulation from lint chamber, thermostat, and microprocessor temperature sensor (sensor bracket) area.

WARNING: TO AVOID THE HAZARD OF ELECTRICAL SHOCK, DISCONTINUE ELECTRICAL SUPPLY TO THE DRYER.

90 DAYS

Inspect and remove lint accumulation in customer furnished exhaust duct work system and from dryers internal exhaust ducting.

NOTE: THE ACCUMULATION OF LINT IN THE EXHAUST DUCT WORK CAN CREATE A POTENTIAL FIRE HAZARD.

NOTE: DO NOT OBSTRUCT THE FLOW OF COMBUSTION and VENTILATION AIR. CHECK CUSTOMER FURNISHED BACK DRAFT DAMPERS IN THE EXHAUST DUCT WORK. INSPECT and REMOVE ANY LINT ACCUMULATION WHICH CAN CAUSE THE DAMPER TO BIND or STICK.

NOTE: A back draft damper that is sticking partially closed can result in slow drying and shutdown of heat circuit safety switches or thermostats

NOTE: When cleaning the dryer cabinet(s), avoid using harsh abrasives. A product intended for the cleaning of appliances is recommended.

B. ADJUSTMENTS

7 DAYS AFTER INSTALLATION and EVERY 6 MONTHS THEREAFTER

Inspect bolts, nuts, screws, (bearing set screws), non-permanent gas connections (unions, shut-off valves, orifices, and grounding connections). Motor and drive belts **should be** examined. Cracked or seriously frayed belts **should be** replaced. Tighten loose V-belts when necessary. Complete operational check of controls and valves. Complete operational check of **ALL** safety devices (door switches, lint drawer switch, sail switch, burner and hi-limit thermostats).

C. LUBRICATION

The motor bearings, idler bearings, and tumbler bearings are permanently lubricated. **NO LUBRICATION IS NECESSARY.**

SECTION VII

TROUBLE SHOOTING

IMPORTANT: YOU MUST DISCONNECT and LOCKOUT THE ELECTRIC SUPPLY and THE GAS SUPPLY or THE STEAM SUPPLY BEFORE ANY COVERS or GUARDS ARE REMOVED FROM THE MACHINE TO ALLOW ACCESS FOR CLEANING, ADJUSTING, INSTALLATION, OR TESTING OF ANY EQUIPMENT PER OSHA (Occupational Safety and Health Administration) STANDARDS.

The information provided will help isolate the most probable component(s) associated with the difficulty described. The experienced technician realizes, however, that a loose connection or broken/shorted wire may be at fault where electrical components are concerned .. not necessarily the suspect component itself. Electrical parts should always be checked for failure before being returned to the factory.

IMPORTANT: When replacing blown fuses, the replacement must be of the exact rating as the fuse being replaced. The information provided should not be misconstrued as a handbook for use by a untrained person in making repairs.

WARNING: All SERVICE and TROUBLESHOOTING SHOULD BE PERFORMED BY A QUALIFIED PROFESSIONAL OR SERVICE AGENCY.

WARNING: WHILE MAKING REPAIRS, OBSERVE ALL SAFETY PRECAUTIONS DISPLAYED ON THE DRYER OR SPECIFIED IN THIS MANUAL.

Microprocessor (Coin) Models

A. No LED display ...

1. Service panel fuse blown or tripped breaker.
2. Blown FU1 (fuse 1) or FU2 (fuse 2).
3. Failed microprocessor controller (computer).

B. Drive motor not operating (does not start) ...

1. Microprocessor (computer) motor indicator dot and relay output LED indicator are on...

- a. Failed drive motor contactor (relay).
- b. Failed drive motor.

2. Microprocessor (computer) motor indicator dot and "door" LED indicator are on, but motor output LED indicator is off...

- a. Failed microprocessor controller (computer).

C. The dryer will not stop, even with no cycle in progress...

1. Failed motor contactor/relay.

D. The dryer operates for a few minutes, stops and then restarts on its own...

1. Motor is overheating and tripping out on the internal overload.

- a. Motor air vents clogged with lint.
- b. Low voltage to motor.
- c. Failed motor.
- d. Failed idler bearing or tumbler bearing.

E. The dryer runs for a few minutes and then stops...microprocessor controller (computer) LED display continues to read cycle in progress and indicator dots are off...

1. Fault in the main door switch circuit.
 - a. Failed main door switch.

- b. Main door switch is out of adjustment.
- c. Loose connection or broken wire in door switch harness.

F. The dryer does not start, and the microprocessor controller (computer) LED display shows "dOOr" ...

- 1. Failed door switch.
- 2. Loose connection or broken wire in door switch harness.
- 3. Failed microprocessors controller (computer).

G. Microprocessor controller (computer) display reads "dSFL"...

- 1. Fault in microprocessor heat sensing circuit...
 - a. Blown 1/8-amp (Slo Blo) fuse on microprocessor controller (computer)...shorted wire in sensor harness would cause this.
 - b. Failed microprocessor temperature sensor.
 - c. Loose connection or broken wire in sensor harness between the sensor bracket and the microprocessor controller (computer).
 - d. Failed microprocessor controller (computer).

H. Microprocessor controller (computer) will not accept any, or only accept certain keyboard entries...

- 1. Failed keyboard label (touchpad) assembly.
- 2. Failed microprocessor controller (computer).

I. Microprocessor controller (computer) locks up and a LED display reads erroneous message(s) or only partial segments...

- 1. Transient power voltage (spikes)...disconnect power to dryer, wait one (1) minute and reestablish power to dryer. If problem is still evident...
 - a. Failed keyboard label (touchpad) assembly.
 - b. Failed microprocessor controller (computer).

J. Dryer stops during a cycle and microprocessor controller (computer) LED display returns to "FILL" ...

1. Loose connection in main power circuit to microprocessor controller (computer).
2. Loose connection in wires between the temperature sensor and microprocessor controller (computer).

K. Gas heating unit is not operating (no heat)...no spark at burner area when dryer is first started and heat indicator dot is on...

1. Fault in sail switch circuit...
 - a. Sail switch is out of adjustment or has failed.
 - b. Sail switch damper is not closing or is fluttering...
 - 1) Lint drawer or lint screen is dirty or clogged.
 - 2) Restriction in exhaust duct work.
2. Fault in burner hi-limit circuit or thermostat.
3. Fault in lint chamber sensor bracket hi-heat protector thermostat.
4. Failed Direct Spark Ignition (DSI) module (burner control).
5. Failed DSI ignitor/flame-probe assembly.
6. Failed microprocessor controller (computer).

L. No heat (gas models)...ignitor sparks, burner goes on and off right away...

1. DSI ignitor/flame-probe out of adjustment...reposition closer to the flame area.
2. Sail switch is fluttering...
 - a. Lint drawer/screen is dirty or clogged.
 - b. Restriction in exhaust duct work.
3. Insufficient make-up air.
4. Failed ignitor/flame-probe assembly.
5. Failed Direct Spark Ignition (DSI) module (burner control).
6. Failed gas valve.

M. Dryer operates, but is taking too long to dry...

1. Exhaust duct work run is too long or is undersized...back pressure *cannot* exceed 0.3 inches water column.
2. Failed microprocessor controller (computer).
3. Low and/or inconsistent gas pressure.
4. Insufficient make-up air.
5. Poor air/gas mixture at burner...yellow or poor flame pattern. Adjust gas burner air adjustment shutters.
6. Lint screen not being cleaned on a regular basis or not often enough.
7. Extractors (washers) not performing properly.
8. Sail switch is fluttering...restriction in exhaust .
9. Failed microprocessor controller (computer)...temperature calibration is inaccurate
(*Microprocessor [Computer] Models ONLY*).
10. Failed microprocessor temperature sensor...calibration is inaccurate (*Microprocessor [Computer] Models ONLY*).
11. Failed burner/oven hi-limit .
12. Failed lint chamber hi-heat protector thermostat.

N. Condensation on main door glass...

1. Too long, undersized, or improperly installed duct work.
2. Exhaust back draft damper is stuck closed or partially closed.

O. Dryer or scraping noise at basket (tumbler) area...

1. Check for object caught in basket (tumbler)/wrapper area.
2. Basket (tumbler) is out of proper alignment...
 - a. Check both vertical and lateral alignment.
 - b. Check gap between front panel and basket (tumbler) front...set screws may have come loose and the basket (tumbler) walked forward or walked backwards.
 - c. Loose basket (tumbler) tie rod.
 - d. Failed basket (tumbler) support.

P Coins are accepted but do not register...LED display continues to read "FILL"...

1. Failed coin optic sensor.
2. Loose connection in optic sensor harness.
3. Poor ground connection of optic sensor.
4. Failed microprocessor controller (computer).

Mechanical Coin Meter

A. Dryer will not start...indicator light is off...

1. Dryer control circuit fuse is blown.
2. Open circuit at location...service main fuse or circuit breaker.
3. Failed push to start relay.
4. Failed door switch and/or circuit.
5. Failed coin mechanism.

B. Drive motor not operating (does not start)... Indicator light is on ...

1. Failed drive motor contactor (relay).
2. Failed drive motor.

C. Drive motor operates okay for a few minutes, and then stops and will not restart...

1. Motor is overheating and tripping out on overload protector...
 - a. Motor air vents clogged with lint.
 - b. Low voltage to the motor.
 - c. Failed motor.
 - d. Basket (tumbler) is binding...check for obstruction.
 - e. Failed idler bearings or tumbler bearings.
 - f. Failed impellor/fan ... out of balance.

D. Heating unit is not operating (no heat)...no voltage at heating unit (i.e., DSI module)

Gas Models

1. Fault in sail switch circuit...
 - a. Sail switch is out of adjustment or has failed.
 - b. Sail switch damper is not closing or is fluttering...
 - 1) Lint screen is dirty.
 - 2) Restriction in exhaust.
 - 3) No exhaust air flow...
 - a) Failed impellor (fan/blower).
 - b) Fault in impellor (fan) motor circuit.
2. Failed burner hi-limit switch.
3. Failed lint chamber sensor bracket basket (tumbler) hi-limit switch or circuit.
4. Failed temperature selection switch or circuit.
5. Failed temperature cycle thermostat (try another selection).
6. Failed heat timer.

E. No heat...voltage is confirmed at heating unit (i.e., DSI module)...

Gas Models

1. Fault in Direct Spark Ignition (DSI) ignition system...
 - a. Ignitor sparks but no ignition and Direct Spark Ignition (DSI) module locks out (red LED indicator light stays on)...
 - 1) Ignitor probe assembly is out of adjustment or has failed.
 - 2) Severe air turbulence.
 - 3) Failed Direct Spark Ignition (DSI) module.
 - 4) Failed gas valve.

- b. Ignitor sparks, burner lights but goes off right away...
 - 1) Direct Spark Ignition (DSI) ignitor out of adjustment...or has failed.
 - 2) Sail switch is fluttering...
 - a) Lint screen is dirty.
 - b) Restriction in exhaust duct work.
- c. Ignitor does not spark and Direct Spark Ignition (DSI) module locks out (red LED indicator light stays on)...
 - 1) Fault in high voltage (HV) wire...break or loose connection.
 - 2) Failed ignitor probe assembly.
 - 3) Failed Direct Spark Ignition (DSI) module.

F. Dryer operates but is taking too long to dry...

- 1. Exhaust duct work run too long or is undersized...back pressure cannot exceed 0.3 inches water column (W.C.).
- 2. Restriction in exhaust...
 - a. Customer-furnished exhaust back draft damper is sticking partially closed.
 - b. Restriction in duct work...check duct work from dryer all the way to the outdoors.
- 3. Insufficient make-up air.
- 4. Impellor/blower/fan (3-Phase [3ø] Models ONLY) rotating in the wrong direction.
- 5. Lint screen is dirty or is not being cleaned often enough.
- 6. Inadequate air flow...
 - a. Impellor (blower/fan) failure.

7. Gas Models

- a. Low and/or inconsistent gas pressure (Gas Models ONLY)...Natural Gas pressure *must be* between 3.5 inches and 4.0 inches of water column, and Liquid Propane (L.P.) pressure *must be* between 10.5 inches and 11.0 inches of water column.

b. Poor air/gas mixture (too much gas or not enough air) at burner...yellow or poor flame pattern...

1) Not enough make-up air.

2) Restriction in exhaust.

3) Gas pressure too high.

4) Impellor/blower/fan (3-Phase [3Ø] Models ONLY) rotating in the wrong direction.

5) Burner orifice size (D.M.S.) too large for application (i.e., high elevation).

c. Sail switch is fluttering...restriction in exhaust...

1) Lint screen is dirty or is not being cleaned often enough.

2) Restriction in exhaust.

d. Failed burner hi-limit switch...opens at incorrect temperature.

e. Gas supply may have low heating value.

G. Main burners are burning with a yellow flame (for Gas Models ONLY)...

1. Poor air/gas mixture (too much gas or not enough air) at burner...

a. Not enough make-up air.

b. Restriction in exhaust.

c. Gas pressure too high.

d. Impellor (blower/fan) is rotating in the wrong direction (3-phase [3Ø] Models ONLY).

e. Burner orifice size (D.M.S.) too large for application (i.e., high elevation).

H. Condensation on main door glass...

1. Too long, undersized, or improperly installed duct work.

2. Back draft damper in duct work is sticking in partially closed position.

I. Dryer or scraping noise at basket (tumbler) area...

1. Check for object caught in basket (tumbler)/wrapper area.
2. Basket (tumbler) is out of proper alignment.
 - a. Check both vertical alignment and lateral alignment.
 - b. Check gap between front panel and basket (tumbler)...set screws may have come loose, and basket (tumbler) walked forward or backward.
3. Loose basket (tumbler) tie rod.
4. Failed basket (tumbler) support.

J. Excessive noise and/or vibration...

1. Dryer is not leveled properly.
2. Impellor (fan blower) is out of balance.
 - a. Excessive lint build up impellor (fan/blower).
 - b. Failed impellor (fan/blower).
3. Loose basket (tumbler) tie rod.
4. Basket (tumbler) is out of adjustment, or adjustment bolts (hardware) are loose.
5. Failed basket (tumbler) support.
6. Loose motor mount.
7. Failed idler, basket (tumbler), or fan (impellor) bearings.
8. V-belt(s) either too tight or too loose.
9. Bearing set screws (basket [tumbler], idler, or impellor [blower] shaft) are loose.
10. Failed motor bearings.

(OPL) Microprocessor (Computer) Models

A. No display (microprocessor [computer] models ONLY)...

1. Service panel fuse blown or tripped breaker.
2. Blown control circuit L1 or L2 1/2-amp (Slo Blo) fuse.
3. Failed microprocessor controller (computer).
4. Failed control step down transformer (for models 380 volts or higher ONLY).

B. Drive motor not operating (does not start)...

1. Microprocessor (computer) motor indicator dot and relay output LED indicator are on...
 - a. Failed drive motor contactor (relay).
 - b. Failed drive motor.
2. Microprocessor (computer) motor indicator dot and "door" LED indicator are on, but motor output LED indicator is off...
 - a. Failed microprocessor controller (computer).

C. Drive motor operates okay for a few minutes, and then stops and will not restart...

1. Motor is overheating and tripping out on the internal overload protector...
 - a. Motor air vents clogged with lint.
 - b. Low voltage to motor.
 - c. Failed motor.
 - d. Basket (tumbler) is binding...check for an obstruction.
 - e. Failed idler bearings or tumbler bearings.
 - f. Failed Impellor (blower/fan)... out of balance.

D. Drive motor runs for a few minutes and stops... microprocessor controller (computer) LED display continues to read time or percent of extraction and ALL indicator dots are off...

1. Fault in main door switch circuit...
 - a. Main door switch out of adjustment.
 - b. Loose connection in door switch circuit.

E. Microprocessor controller (computer) display reads "dSFL" continuously and the buzzer (tone) sounds every 30-seconds...

1. Fault in microprocessor heat-sensing circuit...
 - a. Blown "dSFL" 1/8-amp fuse on the microprocessor controller (computer).
 - b. Failed microprocessor temperature sensor.
 - c. Failed microprocessor controller (computer).
 - d. Broken wire or connection somewhere between the microprocessor controller (computer) and microprocessor temperature sensor.

F. Microprocessor controller (computer) display reads "dOOr" and microprocessor controller (computer) "dOOr" LED indicator is off...

1. Fault (open circuit) in main door switch circuit...
 - a. Main door not closed all the way.
 - b. Main door switch out of proper adjustment.
 - c. Failed door switch.
 - d. Broken connection/wire in main door switch circuit.

2. Failed 24 VAC step down transformer or fault in wiring.

G. Microprocessor controller (computer) LED display reads "dOOr" and microprocessor controller (computer) "dOOr" LED indicator is on...

1. Failed microprocessor controller (computer).

H. Microprocessor controller (computer) will not accept any keyboard (touchpad) entries, i.e., display reads "FILL" and when keyboard entries are selected, the display continues to read "FILL"...

1. Failed keyboard label (touchpad) assembly.
2. Failed microprocessor controller (computer).

I. Microprocessor controller (computer) will only accept certain keyboard (touchpad) entries...

1. Failed keyboard label (touchpad) assembly.

J. Microprocessor controller (computer) locks up and display reads erroneous message(s) or only partial segments...

1. Transient power voltage (spikes)...disconnect power to dryer, wait one (1) minute and reestablish power to dryer..if problem is still evident...
 - a. Failed microprocessor controller (computer).
 - b. Failed keyboard label (touchpad) assembly.

K. Dryer stops during a cycle, microprocessor controller (computer) buzzer (tone) sounds for 5-seconds, and then LED display reads "dSFL", for approximately 30-seconds, and then returns to "FILL"...

1. Loose connection somewhere between the microprocessor controller (computer) and the microprocessor temperature sensor.
2. Loose "dSFL" 1/8-amp fuse on the microprocessor controller (computer).

L. Dryer stops during a cycle, microprocessor controller (computer) buzzer (tone) sounds for 5-seconds, and then the LED display returns to "FILL"...

1. Loose connection somewhere in the main power circuit to the microprocessor controller (computer).

M. Microprocessor controller (computer) LED display reads "SEFL"...

1. Rotational sensor circuit (option) failure...fault somewhere in basket (tumbler) rotation or circuit...
 - a. Basket (tumbler) not rotating...
 - 1) Broken or loose V-belts.

2) Failure in drive motor circuit...refer to **Item B, and/or Item C** in this **Troubleshooting Section.**

b. Failed rotational sensor.

c. Broken wire or connection between sensor and microprocessor controller (computer).

2. Microprocessor controller (computer) program (PL02) is set incorrectly in the active mode ("SEn") where the dryer is not equipped with the *OPTIONAL* rotational sensor...program *should be* set as "nSEn".

N. Microprocessor controller (computer) LED display reads "Hot"...

1. Possible overheating condition...microprocessor controller (computer) has sensed a temperature which has exceeded 220° F.

"Hot" display *will not* clear until temperature sensed has dropped to 220° F or lower and the microprocessor controller (computer) is manually reset by pressing the "CLEAR/STOP" key.

O. Heating unit is not operating (no heat)...no voltage at heating unit (i.e., DSI module,) when dryer is first started and both the heat indicator dot and the "HEAT" output LED ARE ON...

Gas Models

1. Fault in sail switch circuit...

a. Sail switch is out of adjustment or has failed.

b. Sail switch damper is not closing or is fluttering...

1) Lint screen is dirty.

2) Restriction in exhaust.

3) No exhaust air flow...

a) Failed impellor (blower/fan).

b) Fault in impellor (blower/fan) motor circuit.

2. Failed burner hi-limit switch.

3. Failed lint chamber sensor bracket basket (tumbler) hi-limit switch.

P. Heating unit is not operating (no heat)...no voltage at heating unit (i.e., DSI module,) when dryer is first started and the microprocessor controller (computer) heat indicator dot is on but the "HEAT" relay output LED is *NOT ON*.

1. Failed microprocessor controller (computer).

Q. No heat...voltage is confirmed at heating unit (i.e., DSI module,)...

Gas Models

1. Fault in Direct Spark Ignition (DSI) system...

- a. Ignitor sparks but no ignition and Direct Spark Ignition (DSI) module locks out (red LED indicator light stays on)...

- 1) Ignitor probe assembly is out of adjustment or has failed.

- 2) Severe air turbulence.

- 3) Failed Direct Spark Ignition (DSI) module.

- 4) Failed gas valve.

- b. Ignitor sparks, burner lights, but goes off right away...

- 1) DSI ignitor flame probe is out of adjustment or has failed.

- 2) Sail switch is fluttering...

- a) Lint screen is dirty.

- b) Restriction in exhaust duct work.

- c. Ignitor does not spark and Direct Spark Ignition (DSI) module locks out (red LED indicator light stays on)...

- 1) Fault in high voltage (HV) wire...break or loose connection.

- 2) Failed ignitor probe assembly.

- 3) Failed Direct Spark Ignition (DSI) module.

R. Dryer is taking too long to dry...

1. Exhaust duct work run too long or is undersized...back pressure cannot exceed 0.3 inches water column.
2. Restriction in exhaust...
 - a. Dryer back draft damper is sticking partially closed.
 - b. Restriction/obstruction in duct work...
 - 1) Check duct work from dryer all the way to the outdoors.
3. Insufficient make-up air.
4. Impellor (blower/fan) is rotating in the wrong direction (3-phase [3Ø] Models ONLY).
5. Lint drawer screen is dirty or is not being cleaned often enough.
6. Inadequate air flow...
 - a. Impellor (blower/fan) failure.

7. Gas Models

- a. Low and/or inconsistent gas pressure...
 - 1) Natural Gas pressure *must be* between 3.5 inches and 4.0 inches of water column.
 - 2) Liquid propane (L.P.) pressure *must be* between 10.5 inches and 11.0 inches of water column.
- b. Poor air/gas mixture (too much gas or not enough air) at burner...yellow or poor flame pattern...
 - 1) Not enough make-up air.
 - 2) Restriction in exhaust.
 - 3) Gas pressure too high.
 - 4) Impellor (blower/fan) rotating in the wrong direction.
 - 5) Burner orifice size (D.M.S.) too large for application (i.e., high elevation).
- c. Sail switch is fluttering...

1) Restriction in exhaust...

a) Lint screen is dirty or is not being cleaned often enough.

d. Failed burner hi-limit switch...opens at incorrect temperature.

e. Gas supply may have low heating value.

8. Extractors (washers) not functioning properly.

9. Failed microprocessor controller (computer)...temperature calibration is inaccurate.

10. Failed microprocessor temperature sensor...calibration is inaccurate.

11. Failed lint chamber hi-heat thermostat...opens at incorrect temperature.

12. Microprocessor temperature sensor is covered with lint.

S. At completion of the "AUtO" drying/cooling cycle...load is coming over dried...

1. Percentage of dryness (dryness level) of cycle selected is too high.

2. "A" and "B" factors not set correctly or "B" factor has to be adjusted for adverse location conditions.

T. At completion of the "AUtO" drying/cooling cycle...load is coming damp...

1. Percentage of dryness (dryness level) of cycle selected is too low.

2. "A" and "B" factors not set correctly or "B" factor has to be adjusted for adverse location conditions.

U. Main burners are burning with a yellow flame (for Gas Models ONLY)...

1. Poor air/gas mixture (too much gas or not enough air at burner)...

a. Not enough make-up air.

b. Restriction in exhaust.

c. Gas pressure too high.

d. Impellor/blower/fan (3-Phase [3Ø] Models ONLY) rotating in the wrong direction.

e. Burner orifice size (D.M.S.) too large for application (i.e., high elevation).

V. Condensation on main door glass...

1. Too long, undersized, or improperly installed duct work.
2. Back draft damper is sticking in the partially closed position.

W. Dryer or scraping noise at basket (tumbler) area...

1. Check for obstruction caught in basket (tumbler)/wrapper area.
2. Basket (tumbler) is out of proper alignment.
 - a. Check both vertical alignment and lateral alignment.
 - b. Check gap between front panel and the basket tumbler...bearing set screws may have come loose, and basket (tumbler) walked forward or backward.

AA. Excessive noise and/or vibration...

1. Dryer is not leveled properly.
2. Impellor (blower/fan) out of balance...
 - a. Excessive lint build up on impellor (blower/fan).
 - b. Failed impellor (blower/fan).
3. Loose basket (tumbler) tie rod.
4. Failed basket (tumbler) support.
5. Loose motor mount.
6. Failed idler bearings or basket (tumbler) bearings.
7. V-belts too tight or too loose.
8. Tumbler bearings set screws are loose.
9. Failed motor bearings.

TIMER MODELS

A. Dryer will not start...drive motor is not operating (indicator light is off)...

1. Service panel fuse blown or tripped breaker.
2. Dryer control circuit L1 or L2 1/2-amp fuse is blown.
3. Open in main door switch circuit...
 - a. Main door switch is not closed all the way.
 - b. Main door switch is out of proper adjustment.
 - c. Failed main door switch.
 - d. Broken connection/wire in main door switch circuit.
4. Failed push to start relay.
5. Failed 24 VAC step down transformer or fault in wiring.
6. Failed heat timer.
7. Failed control step down transformer (for models 380 volts or higher ONLY).

B. Drive motor not operating (does not start)... Indicator light is on ...

1. Failed drive motor contactor (relay).
2. Failed drive motor.

C. Drive motor operates okay for a few minutes, and then stops and will not restart...

1. Motor is overheating and tripping out on overload protector...
 - a. Motor air vents clogged with lint.
 - b. Low voltage to the motor.
 - c. Failed motor.
 - d. Basket (tumbler) is binding...check for obstruction.
 - e. Failed idler bearings or tumbler bearings.

f. Failed impellor/fan ... out of balance.

D. Heating unit is not operating (no heat)...no voltage at heating unit (i.e., DSI module)

Gas Models

1. Fault in sail switch circuit...

a. Sail switch is out of adjustment or has failed.

b. Sail switch damper is not closing or is fluttering...

1) Lint screen is dirty.

2) Restriction in exhaust.

3) No exhaust air flow...

a) Failed impellor (fan/blower).

b) Fault in impellor (fan) motor circuit.

2. Failed burner hi-limit switch.

3. Failed lint chamber sensor bracket basket (tumbler) hi-limit switch or circuit.

4. Failed temperature selection switch or circuit.

5. Failed temperature cycle thermostat (try another selection).

6. Failed heat timer.

E. No heat...voltage is confirmed at heating unit (i.e., DSI module)...

Gas Models

1. Fault in Direct Spark Ignition (DSI) ignition system...

a. Ignitor sparks but no ignition and Direct Spark Ignition (DSI) module locks out (red LED indicator light stays on)...

1) Ignitor probe assembly is out of adjustment or has failed.

2) Severe air turbulence.

3) Failed Direct Spark Ignition (DSI) module.

- 4) Failed gas valve.
- b. Ignitor sparks, burner lights but goes off right away...
 - 1) Direct Spark Ignition (DSI) ignitor out of adjustment...or has failed.
 - 2) Sail switch is fluttering...
 - a) Lint screen is dirty.
 - b) Restriction in exhaust duct work.
- c. Ignitor does not spark and Direct Spark Ignition (DSI) module locks out (red LED indicator light stays on)...
 - 1) Fault in high voltage (HV) wire...break or loose connection.
 - 2) Failed ignitor probe assembly.
 - 3) Failed Direct Spark Ignition (DSI) module.

F. Dryer operates but is taking too long to dry...

- 1. Exhaust duct work run too long or is undersized...back pressure cannot exceed 0.3 inches water column (W.C.).
- 2. Restriction in exhaust...
 - a. Customer-furnished exhaust back draft damper is sticking partially closed.
 - b. Restriction in duct work...check duct work from dryer all the way to the outdoors.
- 3. Insufficient make-up air.
- 4. Impellor/blower/fan (3-Phase [3Ø] Models ONLY) rotating in the wrong direction.
- 5. Lint screen is dirty or is not being cleaned often enough.
- 6. Inadequate air flow...
 - a. Impellor (blower/fan) failure.

7. Gas Models

- a. Low and/or inconsistent gas pressure (Gas Models ONLY)...Natural Gas pressure *must be* between 3.5 inches and 4.0 inches of water column, and Liquid Propane (L.P.) pressure

must be between 10.5 inches and 11.0 inches of water column.

b. Poor air/gas mixture (too much gas or not enough air) at burner...yellow or poor flame pattern...

1) Not enough make-up air.

2) Restriction in exhaust.

3) Gas pressure too high.

4) Impellor/blower/fan (3-Phase [3 ϕ] Models ONLY) rotating in the wrong direction.

5) Burner orifice size (D.M.S.) too large for application (i.e., high elevation).

c. Sail switch is fluttering...restriction in exhaust...

1) Lint screen is dirty or is not being cleaned often enough.

2) Restriction in exhaust.

d. Failed burner hi-limit switch...opens at incorrect temperature.

e. Gas supply may have low heating value.

G. Main burners are burning with a yellow flame (for Gas Models ONLY)...

1. Poor air/gas mixture (too much gas or not enough air) at burner...

a. Not enough make-up air.

b. Restriction in exhaust.

c. Gas pressure too high.

d. Impellor (blower/fan) is rotating in the wrong direction (3-phase [3 ϕ] Models ONLY).

e. Burner orifice size (D.M.S.) too large for application (i.e., high elevation).

H. Condensation on main door glass...

1. Too long, undersized, or improperly installed duct work.

2. Back draft damper in duct work is sticking in partially closed position.

I. Dryer or scraping noise at basket (tumbler) area...

1. Check for object caught in basket (tumbler)/wrapper area.
2. Basket (tumbler) is out of proper alignment.
 - a. Check both vertical alignment and lateral alignment.
 - b. Check gap between front panel and basket (tumbler)...set screws may have come loose, and basket (tumbler) walked forward or backward.
3. Loose basket (tumbler) tie rod.
4. Failed basket (tumbler) support.

J. Excessive noise and/or vibration...

1. Dryer is not leveled properly.
2. Impellor (fan blower) is out of balance.
 - a. Excessive lint build up impellor (fan/blower).
 - b. Failed impellor (fan/blower).
3. Loose basket (tumbler) tie rod.
4. Basket (tumbler) is out of adjustment, or adjustment bolts (hardware) are loose.
5. Failed basket (tumbler) support.
6. Loose motor mount.
7. Failed idler, basket (tumbler), or fan (impellor) bearings.
8. V-belt(s) either too tight or too loose.
9. Bearing set screws (basket [tumbler], idler, or impellor [blower] shaft) are loose.
10. Failed motor bearings.

SECTION VIII

TECHNICAL INFORMATION

A. DATA LABEL

Contact American Dryer Corporation

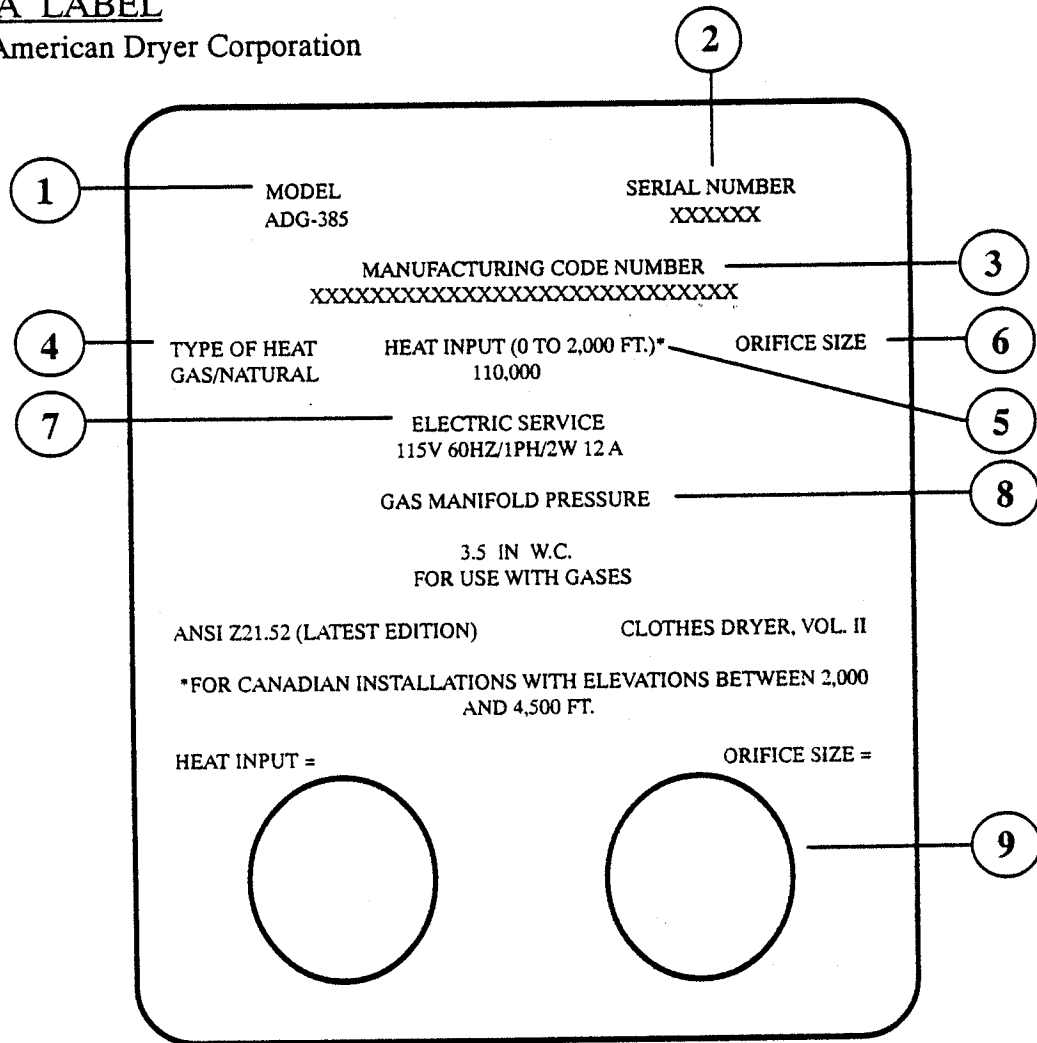

When contacting American Dryer Corporation certain information is required to insure proper service / parts information from American Dryer. This information is on the data label located on the inside of the control door. When contacting American Dryer please have the model number and serial number handy.

THE DATA LABEL

1. MODEL NUMBER— The model number is an ADC number which describes the size of the dryer and type of heat (gas, electric, or steam).
2. SERIAL NUMBER— The serial number allows ADC to gather information on your particular dryer.
3. MANUFACTURING CODE NUMBER — The manufacturing code number is a number issued by ADC which describes all possible options on your particular model.
4. TYPE OF HEAT — Describes the type of heat ; gas (natural or L.P.), steam or electric.
5. HEAT INPUT — (For gas dryers) describes the heat input in british thermal units.
6. ORIFICE SIZE — Gives the number size drill used.
7. ELECTRIC SERVICE —Describes the electric service for your particular model.
8. GAS MANIFOLD — Describes the manifold pressure as taken at the gas valve.
9. APPLICABLE APPROVAL SEAL(S) — I.E. American Gas Association, Canadian Gas Association.

SECTION IX

PROCEDURE FOR FUNCTIONAL CHECK OF REPLACEMENT COMPONENTS

1. Microprocessor (computer) Board

- a. Upon completing installation of the replacement microprocessor (computer) board, reestablish power to the dryer.
- b. Start the drying cycle.
- c. Verify that the motor(s) and the heat indicator dots, in the microprocessor (computer) LED display are on. (Refer to the illustration below.)

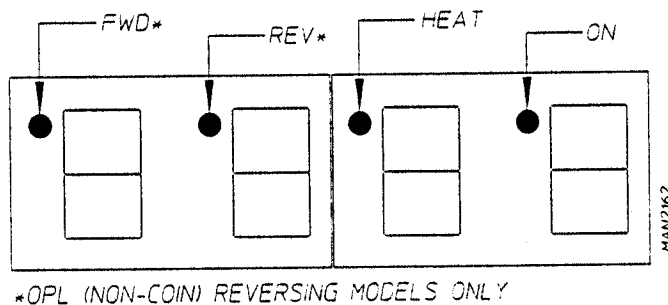

- d. Verify that the motor(s) heat, and door indicator lights on the back side of the microprocessor (computer) board are lit. (Refer to the illustration below.)

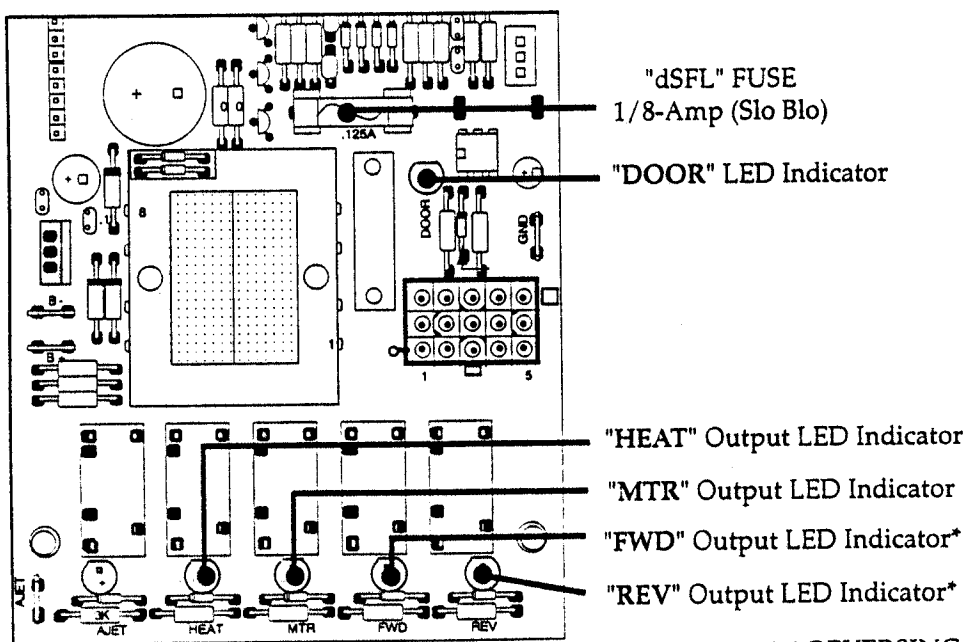

* OPL (non-coin) REVERSING MODELS ONLY

- e. Open main door. The dryer **must stop** and **ALL** indicator lights on the back side of the microprocessor (computer) board **must go out**.
- f. Try to restart the dryer with the main door open.
- g. The microprocessor (computer) board's LED display **must read "DOOR."**
- h. Close the main door and restart the dryer.
- i. Functional check of microprocessor (computer) board is complete.

2. Direct Spark Ignition (DSI) System

- a. Upon completing installation of the replacement Direct Spark Ignition (DSI) module, reestablish power to the dryer.
- b. Start the drying cycle.
- c. The ignition (DSI) module's LED indicator will light "red" for up to approximately 1.5 seconds (pre-purge time).
- d. The module's indicator light will then turn "green."
The gas valve will be energized and the ignitor probe will spark for approximately 8 seconds. The burner flame should now be established.
- e. With the burner flame on, remove the flame sensor wire from the FP terminal of the DSI module.
- f. The burner flame **must shut off** and the ignition module **must lock out** with the DSI module's indicator light "red."
- g. Stop the drying cycle, with the flame sensor wire still removed, restart the drying cycle.
- h. The ignition module **must proceed** through the pre-purge, with the indicator light "red," the ignition trial time of approximately 8 seconds, with the indicator light "green," and then proceed to lock out with the indicator light "red."
- i. Functional check of the Direct Spark Ignition (DSI) Module is complete.
 - 1) Replace the flame sensor wire from the FP terminal to the DSI module.

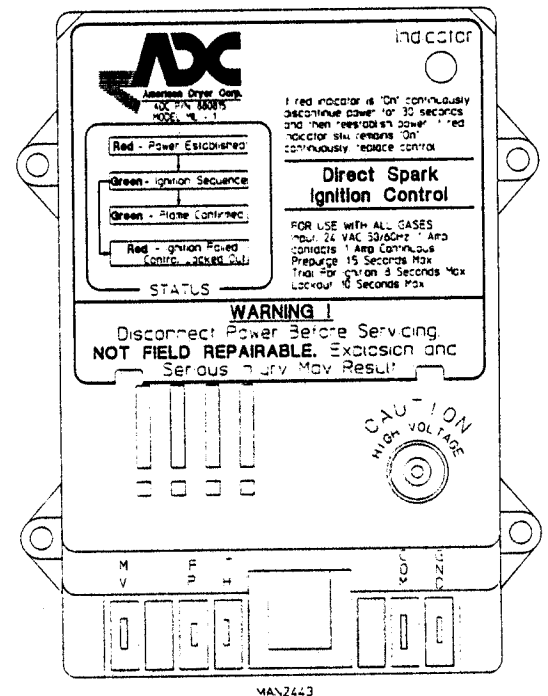

ADC 112188 1- 06/11/96-100 2- 08/05/96-25 3- 08/23/96-50
4* 02/18/97-50 5* 08/20/97-50 6- 08/28/97-100
7* 02/26/98-100 8* 05/15/98-100 9* 12/07/98-100
10- 04/05/99-100 11- 09/21/99-100 12- 11/19/99-25
13- 01/19/00-100 14- 04/18/00-150 15- 01/16/01-150



Free Manuals Download Website

<http://myh66.com>

<http://usermanuals.us>

<http://www.somanuals.com>

<http://www.4manuals.cc>

<http://www.manual-lib.com>

<http://www.404manual.com>

<http://www.luxmanual.com>

<http://aubethermostatmanual.com>

Golf course search by state

<http://golfingnear.com>

Email search by domain

<http://emailbydomain.com>

Auto manuals search

<http://auto.somanuals.com>

TV manuals search

<http://tv.somanuals.com>