

# ASHLY

## Compressor/Limiters

model **CL-50E**  
model **CL-52E**

Five-Year Worry-Free Warranty



CL-50E



CL-52E

Ashly's Compressor/Limiters are used to place a ceiling on the peak levels of program material. When peaks exceed this ceiling, gain is reduced to keep peaks within specified limits. The amount of gain reduction, attack and release times, and the output gain matching are all precise and independent adjustments. This makes the **CL-50E** and the **CL-52E** extremely useful for such diverse applications as loudspeaker protection, broadcast limiting or compression, recording, tape-to-disc transfer, special effects, vocal level control, and musical instrument sustain.

The two important components of any limiter are the VCA (Voltage Controlled Amplifier), which actually performs the function of reducing gain, and the detector, which essentially tells the VCA what to do, i.e. when to reduce the gain and by how much. On the surface, it might seem like the VCA is the most critical component, since audio actually passes through it while the detector merely provides it with a DC control voltage, but experience has shown us that both are crucial to the overall sound.

The VCA in Ashly's Compressor/Limiters represents a new generation of integrated circuits that offer exceptionally low noise and distortion figures, flat frequency response, freedom from thermal drift and excellent reliability. Audio signals passing through the VCA emerge clean and uncolored.

The detector has the task of monitoring incoming audio levels and changing the gain of the VCA as determined by the set-

tings of the front panel controls. The detector in Ashly's Compressor/Limiters is a fully symmetrical peak responding type, and includes a 'send-return' loop which allows frequency selective limiting and other effects.

The detector must constantly adjust the gain of the audio path in a manner which keeps the level under control while still sounding acceptable to the listener. This constantly changing gain is a **dynamic** action, while conventional audio measurements like noise and distortion checks are static (constant level). This led us to use a purely subjective approach in the design of the detector; we did a lot of listening to determine what sounded good and what didn't. As a result of this research, we designed the detector to allow the attack and release times to speed up as more and more limiting occurs (the compression ratio also increases), and we utilized a double-release time constant to minimize 'pumping' and 'breathing'. The result is a natural-sounding compressor/limiter that responds very well to a wide variety of audio applications.

The **CL-50E** is Ashly's single channel compressor/limiter. The **CL-52E** is essentially two **CL-50E**'s in one rack space, but it offers improved metering and switching. The **CL-52E** can be used as a stereo compressor/limiter or as two separate mono units. Ten-level meters are provided on each channel to indicate gain-reduction and output level.

The **CL-50E** and **CL-52E** compressor/limiters, like all Ashly products, are now fully covered by Ashly's exclusive five-year worry-free warranty.

Extremely Low Noise and Distortion

Detector Patch Points for Frequency-Selective Limiting

Gain Reduction Meters

In-Out Bypass Switching

Inputs and Outputs May Be Used Balanced or Unbalanced

Unusually Wide Control Range on All Parameters

Output Level Meters and Clipping Indicators (CL-52E)

Front Panel Stereo Tie Switch (CL-52E)

# Specifications

<b>CONTROLS</b>	
stereo tie switch	(CL-52E ONLY)
defeat switch	
gain:	$\pm 30\text{dB}$
ratio:	2:1- $\infty$
attack time:	200 $\mu\text{s}$ - 20mS.
release time:	100mS - 2Sec.
output:	-40dBV - +20dBV
Detector Patch Point:	allows the connection of an EQ for frequency selective limiting

Maximum Input/Output Level:	+20dBm
Input Impedance:	10k $\Omega$ balanced bridging
Output Impedance:	50 $\Omega$ term. w/ 600 $\Omega$ or more
Frequency Response:	$\pm 2\text{dB}$ 20Hz - 20kHz
Distortion:	<.015% THD, 0dBV 20 Hz - 20kHz, no limiting <.15% +18dBV worst case
Hum and Noise:	-95dBV unity gain
Power Requirements:	120 VAC, 50-60Hz, 5W
Size:	19" L x 1 3/4" H x 6" D
Shipping Weight:	8lbs

## Block Diagram

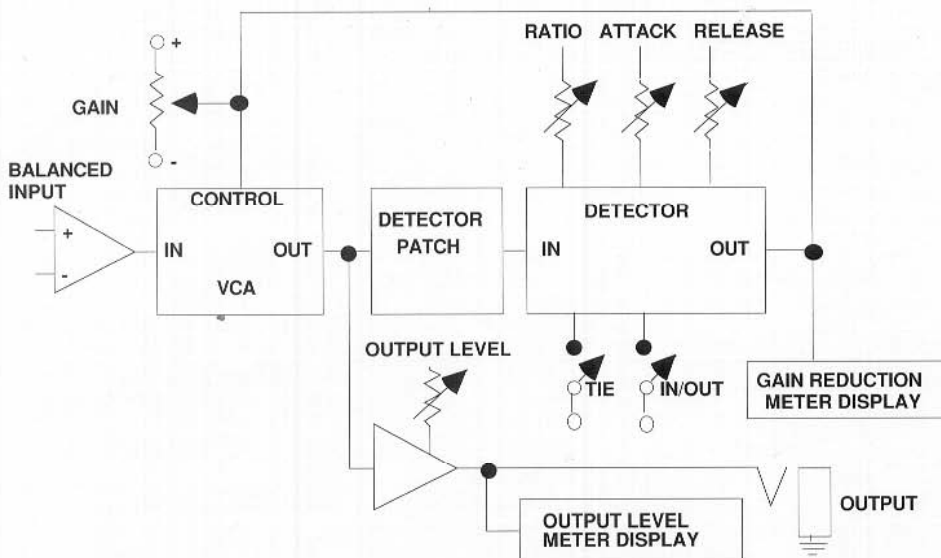

## Architect's Specification

The unit shall be a single (CL-50E) or dual (CL-52E) channel compressor/limiter with independent attack, release and ratio adjustments. It shall have detector patch points which allow connection of an external equalizer in the detector loop to produce frequency selective limiting. It shall have front panel mounted switches for engaging/ defeating the compressor/limiter functions. Performance specifications of a typical production unit shall meet or exceed the following: Gain control shall be  $\pm 30\text{dB}$ . The ratio shall be adjustable from 2:1 to  $\infty$ . The attack time shall be adjustable from 200 $\mu\text{s}$  to 20mS. The release time shall be adjustable from 100mS to 2 seconds. The output shall be adjustable from -40dBV to +20dBV. The maximum in-out level shall be +20dBm. The input impedance shall be 10k $\Omega$  balanced bridging. The output impedance shall be 50 $\Omega$  terminated with 600 $\Omega$  or more. The frequency response shall be 20Hz to 20kHz  $\pm 2\text{dB}$ . Distortion shall be <.015% THD @ 0dBV from 20Hz to 20kHz with no limiting, <.15% @ +18dBV worst case. Hum and noise shall not exceed -90dBV @ unity gain. The unit shall operate at 115VAC  $\pm 5\%$ , 50-60Hz. The unit shall be designed for mounting in a standard EIA 19" rack (19" L x 1.75" H x 6" D) and shall have a shipping weight of 8 lbs. The unit shall be either a model CL-50E (single channel) or a CL-52E (dual channel) Compressor/Limiter manufactured by Ashly Audio Inc. No other unit shall be acceptable unless submitted data from an independent research lab verifies that the above size/performance specs are met.

Many interesting and productive effects can be achieved by combining the CL-50E or the CL-52E with Ashly's SG-33E or SG-35E Noise Gates.

Ashly Audio Inc.  
100 Fernwood Avenue  
Rochester, New York 14621  
Toll Free (800) 828-6308  
In NYS (716) 544-5191

# ASHLY

## Since 1972

© 1990 Ashly Audio

In Canada:  
Gerraudio Dist  
363 Adelaide Street East  
Toronto, M5A 1N3  
(416) 361-1667

## Free Manuals Download Website

<http://myh66.com>

<http://usermanuals.us>

<http://www.somanuals.com>

<http://www.4manuals.cc>

<http://www.manual-lib.com>

<http://www.404manual.com>

<http://www.luxmanual.com>

<http://aubethermostatmanual.com>

Golf course search by state

<http://golfingnear.com>

Email search by domain

<http://emailbydomain.com>

Auto manuals search

<http://auto.somanuals.com>

TV manuals search

<http://tv.somanuals.com>