

CHICAGO  ELECTRIC[®]
POWER TOOLS

2.5 HORSEPOWER INDUSTRIAL BREAKER HAMMER KIT

Model 96035

SET UP AND OPERATING INSTRUCTIONS



Visit our website at: <http://www.harborfreight.com>



**Read this material before using this product.
Failure to do so can result in serious injury.
SAVE THIS MANUAL.**

Copyright© 2007 by Harbor Freight Tools®. All rights reserved. No portion of this manual or any artwork contained herein may be reproduced in any shape or form without the express written consent of Harbor Freight Tools. Diagrams within this manual may not be drawn proportionally. Due to continuing improvements, actual product may differ slightly from the product described herein. Tools required for assembly and service may not be included.

For technical questions or replacement parts, please call 1-800-444-3353.

Revised Manual 10e

SAVE THIS MANUAL

Keep this manual for the safety warnings and precautions, assembly, operating, inspection, maintenance and cleaning procedures. Write the product's serial number in the back of the manual near the assembly diagram (or month and year of purchase if product has no number). Keep this manual and the receipt in a safe and dry place for future reference.

IMPORTANT SAFETY INFORMATION

In this manual, on the labeling, and all other information provided with this product:



This is the safety alert symbol. It is used to alert you to potential personal injury hazards. Obey all safety messages that follow this symbol to avoid possible injury or death.

DANGER

DANGER indicates a hazardous situation which, if not avoided, will result in death or serious injury.

WARNING

WARNING indicates a hazardous situation which, if not avoided, could result in death or serious injury.

CAUTION

CAUTION, used with the safety alert symbol, indicates a hazardous situation which, if not avoided, could result in minor or moderate injury.

NOTICE

NOTICE is used to address practices not related to personal injury.

CAUTION

CAUTION, without the safety alert symbol, is used to address practices not related to personal injury.

General Power Tool Safety Warnings



WARNING Read all safety warnings and instructions. Failure to follow the warnings and instructions may result in electric shock, fire and/or serious injury.

Save all warnings and instructions for future reference.

The term "power tool" in the warnings refers to your mains-operated (corded) power tool or battery-operated (cordless) power tool.

1. **Work area safety**
 - a. **Keep work area clean and well lit.** Cluttered or dark areas invite accidents.
 - b. **Do not operate power tools in explosive atmospheres, such as in the presence of flammable liquids, gases or dust.** Power tools create sparks which may ignite the dust or fumes.
 - c. **Keep children and bystanders away while operating a power tool.** Distractions can cause you to lose control.
2. **Electrical safety**
 - a. **Power tool plugs must match the outlet. Never modify the plug in any way. Do not use any adapter plugs with grounded power tools.** Unmodified plugs and matching outlets will reduce risk of electric shock.
 - b. **Do not expose power tools to rain or wet conditions.** Water entering

a power tool will increase the risk of electric shock.

- c. **Do not abuse the cord. Never use the cord for carrying, pulling or unplugging the power tool. Keep cord away from heat, oil, sharp edges or moving parts. Damaged or entangled cords increase the risk of electric shock.**
- d. **When operating a power tool outdoors, use an extension cord suitable for outdoor use. Use of a cord suitable for outdoor use reduces the risk of electric shock.**
- e. **If operating a power tool in a damp location is unavoidable, use a Ground Fault Circuit Interrupter (GFCI) protected supply. Use of a GFCI reduces the risk of electric shock.**

3. Personal safety

- a. **Stay alert, watch what you are doing and use common sense when operating a power tool. Do not use a power tool while you are tired or under the influence of drugs, alcohol or medication. A moment of inattention while operating power tools may result in serious personal injury.**
- b. **Use personal protective equipment. Always wear eye protection. Safety equipment such as dust mask, non-skid safety shoes, hard hat, or hearing protection used for appropriate conditions will reduce personal injuries.**
- c. **Prevent unintentional starting. Ensure the Trigger is in the off-position before connecting to power source, picking up or carrying the tool. Carrying power tools with your finger on the trigger or energizing power tools that have the trigger depressed invites accidents.**

- d. **Do not overreach. Keep proper footing and balance at all times. This enables better control of the power tool in unexpected situations.**
- e. **Dress properly. Do not wear loose clothing or jewelry. Keep your hair, clothing and gloves away from moving parts. Loose clothes, jewelry or long hair can be caught in moving parts.**
- f. **Only use safety equipment that has been approved by an appropriate standards agency. Unapproved safety equipment may not provide adequate protection. Eye protection must be ANSI-approved and breathing protection must be NIOSH-approved for the specific hazards in the work area.**

4. Power tool use and care

- a. **Do not force the power tool. Use the correct power tool for your application. The correct power tool will do the job better and safer at the rate for which it was designed.**
- b. **Do not use the power tool if the Trigger does not turn it on and off. Any power tool that cannot be controlled with the Trigger is dangerous and must be repaired.**
- c. **Disconnect the plug from the power source before making any adjustments, changing accessories, or storing power tools. Such preventive safety measures reduce the risk of starting the power tool accidentally.**
- d. **Store idle power tools out of the reach of children and do not allow persons unfamiliar with the power tool or these instructions to operate the power tool. Power tools are dangerous in the hands of untrained users.**

e. **Maintain power tools. Check for misalignment or binding of moving parts, breakage of parts and any other condition that may affect the power tool's operation. If damaged, have the power tool repaired before use.** *Many accidents are caused by poorly maintained power tools.*

f. **Keep cutting tools sharp and clean.** *Properly maintained cutting tools with sharp cutting edges are less likely to bind and are easier to control.*

g. **Use the power tool, accessories and tool Chisels etc. in accordance with these instructions, taking into account the working conditions and the work to be performed.** *Use of the power tool for operations different from those intended could result in a hazardous situation.*

5. Service

a. **Have your power tool serviced by a qualified repair person using only identical replacement parts.** *This will ensure that the safety of the power tool is maintained.*

Breaker Hammer Safety Warnings

1. **Wear ear protectors.** *Exposure to noise can cause hearing loss.*

2. **Use auxiliary handles supplied with the tool.** *Loss of control can cause personal injury.*

3. **Hold power tools by insulated gripping surfaces when performing an operation where the cutting tool may contact hidden wiring or its own cord.** *Contact with a "live" wire will make exposed metal parts of the tool "live" and shock the operator.*

4. Do not operate this tool if you have back, neck, or wrist injuries, or other conditions

that will be aggravated by the severe jerking forces that this tool exerts upon the operator.

5. Maintain labels and nameplates on the tool. These carry important safety information. If unreadable or missing, contact Harbor Freight Tools for a replacement.

6. Avoid unintentional starting. Prepare to begin work before turning on the tool.

7. Do not lay the tool down until it has come to a complete stop. Moving parts can grab the surface and pull the tool out of your control.

8. When using a handheld power tool, maintain a firm grip on the tool with both hands to resist starting torque.

9. Do not leave the tool unattended when it is plugged into an electrical outlet. Turn off the tool, and unplug it from its electrical outlet before leaving.

10. This product is not a toy. Keep it out of reach of children.

11. People with pacemakers should consult their physician(s) before use. Electromagnetic fields in close proximity to heart pacemaker could cause pacemaker interference or pacemaker failure. In addition, people with pacemakers should:

- Avoid operating alone.
- Properly maintain and inspect to avoid electrical shock.
- Any power cord must be properly grounded. Ground Fault Circuit Interrupter (GFCI) should also be implemented – it prevents sustained electrical shock.

12. **WARNING:** Some dust created by power sanding, sawing, grinding, drilling, and other construction activities, contains

chemicals known [to the State of California] to cause cancer, birth defects or other reproductive harm. Some examples of these chemicals are:

- Lead from lead-based paints
- Crystalline silica from bricks and cement or other masonry products
- Arsenic and chromium from chemically treated lumber

Your risk from these exposures varies, depending on how often you do this type of work. To reduce your exposure to these chemicals: work in a well ventilated area, and work with approved safety equipment, such as those dust masks that are specially designed to filter out microscopic particles. (California Health & Safety Code § 25249.5, *et seq.*)

13. **WARNING:** Handling the cord on this product will expose you to lead, a chemical known to the State of California to cause cancer, and birth defects or other reproductive harm. Wash hands after handling. (California Health & Safety Code § 25249.5, *et seq.*)
14. The warnings, precautions, and instructions discussed in this instruction manual cannot cover all possible conditions and situations that may occur. It must be understood by the operator that common sense and caution are factors which cannot be built into this product, but must be supplied by the operator.

Vibration Safety

This tool vibrates during use. Repeated or long-term exposure to vibration may cause temporary or permanent physical injury, particularly to the hands, arms and shoulders. To reduce the risk of vibration-related injury:

1. Anyone using vibrating tools regularly or for an extended period should first

be examined by a doctor and then have regular medical check-ups to ensure medical problems are not being caused or worsened from use. Pregnant women or people who have impaired blood circulation to the hand, past hand injuries, nervous system disorders, diabetes, or Raynaud's Disease should not use this tool. If you feel any symptoms related to vibration (such as tingling, numbness, and white or blue fingers), seek medical advice as soon as possible.

2. Do not smoke during use. Nicotine reduces the blood supply to the hands and fingers, increasing the risk of vibration-related injury.
3. Wear suitable gloves to reduce the vibration effects on the user.
4. Use tools with the lowest vibration when there is a choice.
5. Include vibration-free periods each day of work.
6. Let the tool do the work.
7. To reduce vibration, maintain the tool as explained in this manual. If any abnormal vibration occurs, stop use immediately.



SAVE THESE INSTRUCTIONS.

GROUNDING

⚠ WARNING TO PREVENT
ELECTRIC SHOCK
AND DEATH FROM INCORRECT
GROUNDING WIRE
CONNECTION:



Check with a qualified electrician if you are in doubt as to whether the outlet is properly grounded. Do not modify the power cord plug provided with the tool. Never remove the grounding prong from the plug. Do not use the tool if the power cord or plug is damaged. If damaged, have it repaired by a service facility before use. If the plug will not fit the outlet, have a proper outlet installed by a qualified electrician.

Grounded Tools: Tools with Three Prong Plugs

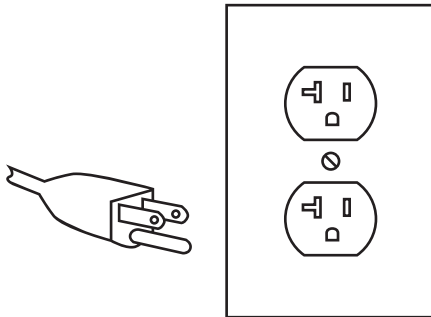

3-Prong Plug and Outlet

1. Tools marked with "Grounding Required" have a three wire cord and three prong grounding plug. The plug must be connected to a properly grounded outlet. If the tool should electrically malfunction or break down, grounding provides a low resistance path to carry electricity away from the user, reducing the risk of electric shock. **(See 3-Prong Plug and Outlet.)**





2. The grounding prong in the plug is connected through the green wire inside the cord to the grounding system in the tool. The green wire in the cord must be the only wire connected to the tool's grounding system and must never be attached to an electrically "live" terminal. **(See 3-Prong Plug and Outlet.)**
3. The tool must be plugged into an appropriate outlet, properly installed and grounded in accordance with all codes and ordinances. The plug and outlet should look like those in the preceding illustration. **(See 3-Prong Plug and Outlet.)**

Extension Cords

1. **Grounded** tools require a three wire extension cord. **Double Insulated** tools can use either a two or three wire extension cord.
2. As the distance from the supply outlet increases, you must use a heavier gauge extension cord. Using extension cords with inadequately sized wire causes a serious drop in voltage, resulting in loss of power and possible tool damage. **(See Table A.)**
3. The smaller the gauge number of the wire, the greater the capacity of the cord. For example, a 14 gauge cord can carry a higher current than a 16 gauge cord. **(See Table A.)**
4. When using more than one extension cord to make up the total length, make sure each cord contains at least the minimum wire size required. **(See Table A.)**

5. If you are using one extension cord for more than one tool, add the nameplate amperes and use the sum to determine the required minimum cord size.
(See Table A.)
6. If you are using an extension cord outdoors, make sure it is marked with the suffix "W-A" ("W" in Canada) to indicate it is acceptable for outdoor use.
7. Make sure the extension cord is properly wired and in good electrical condition. Always replace a damaged extension cord or have it repaired by a qualified electrician before using it.
8. Protect the extension cords from sharp objects, excessive heat, and damp or wet areas.

Symbology

	Double Insulated
	Canadian Standards Association
	Underwriters Laboratories, Inc.
	Volts Alternating Current
	Amperes
n ₀ xxxx/min.	No Load Revolutions per Minute (RPM)

RECOMMENDED MINIMUM WIRE GAUGE FOR EXTENSION CORDS* (120 VOLT)					
NAMEPLATE AMPERES (at full load)	EXTENSION CORD LENGTH				
	25'	50'	75'	100'	150'
0 – 2.0	18	18	18	18	16
2.1 – 3.4	18	18	18	16	14
3.5 – 5.0	18	18	16	14	12
5.1 – 7.0	18	16	14	12	12
7.1 – 12.0	18	14	12	10	-
12.1 – 16.0	14	12	10	-	-
16.1 – 20.0	12	10	-	-	-

TABLE A * Based on limiting the line voltage drop to five volts at 150% of the rated amperes.

SPECIFICATIONS

Electrical Input	120 V~ / 60 Hz / 15 A
Blows Per Minute	1030 BPM
Tool Mount	Spring-Loaded Rotational Lock
Chisel	1 Bull Point (Included)
Weight	77 lb.

UNPACKING

When unpacking, make sure that the item is intact and undamaged. If any parts are missing or broken, please call Harbor Freight Tools at 1-800-444-3353 as soon as possible.

INSTRUCTIONS FOR PUTTING INTO USE



Read the **ENTIRE IMPORTANT SAFETY INFORMATION** section at the beginning of this manual including all text under subheadings therein before set up or use of this product.

WARNING

TO PREVENT SERIOUS INJURY

FROM ACCIDENTAL OPERATION:

Release the Trigger and unplug the tool from its electrical outlet before assembling or making any adjustments to the tool.

Note: For additional information regarding the parts listed in the following pages, refer to the Assembly Diagram near the end of this manual.

Assembly

The only assembly required for the Breaker Hammer is the installing of the Left Handle (92) to the side of the Gear Box (23) and the Spline Axle (27).

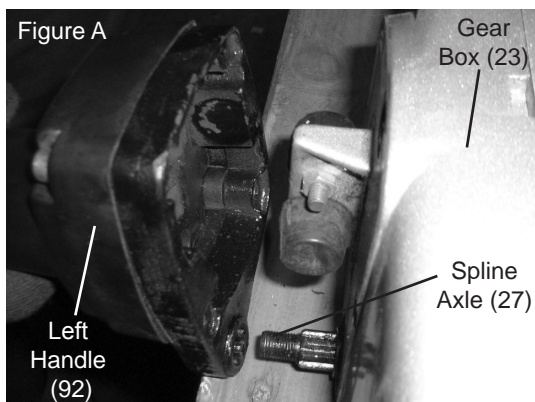

1. First, slide Left Handle over the Spline Axle so that the end of the Spline Axle slides through the opening in the Left Handle. See Figure A.

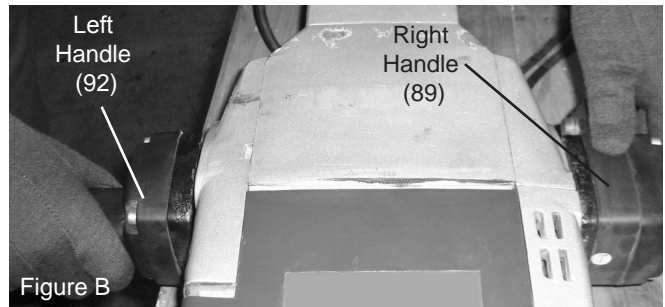

2. With your other hand, hold and slightly twist Right Handle (89) while slowly manipulating Left Handle over the Spline Axle until the splines line up and it fits snug into place. See Figure B.

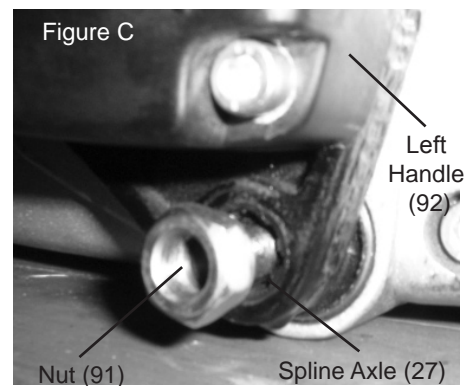

3. Thread Nut (91) over tip of Spline Axle. Use Wrench (not included) to fasten Nut, securing Left Handle in place. Periodically, check Nut for tightness. See Figure C.

Installing a Chisel

Chisels come with or without collars. Figure 1 shows installation of a chisel without a collar (the included chisel is without a collar). Figure 2 shows installation of a chisel with a collar.

Note: If the Chisel doesn't slide in easily, apply some grease on the loading end of the Chisel.

Without a Collar:

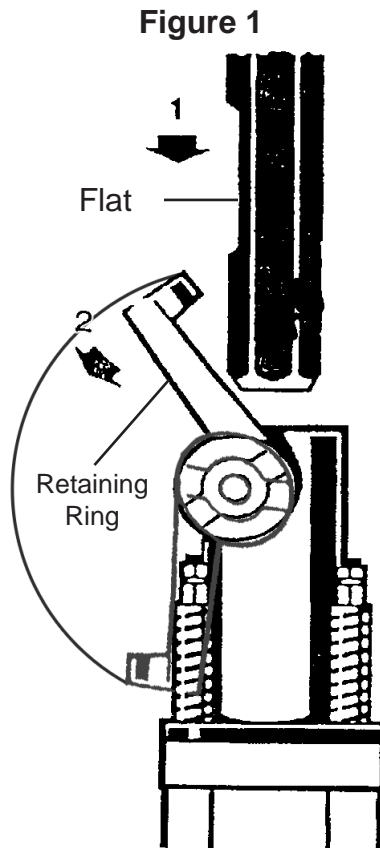

1. Pull the retaining ring to the side just far enough to allow the Chisel to be inserted, as shown in Figure 1. Please note orientation of the flat on the Chisel.

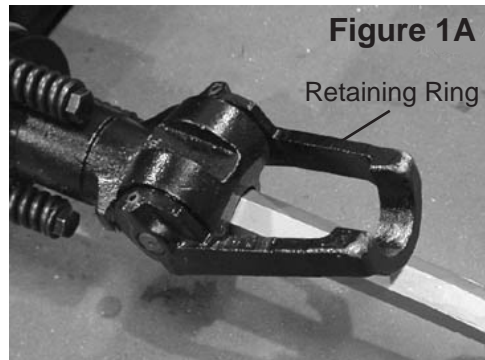

2. Position the retaining ring as shown in Figure 1 and in Figure 1A. Then insert the Chisel with the flat on top of the receiver, as shown.
3. Slide the chisel in as far as it will go.

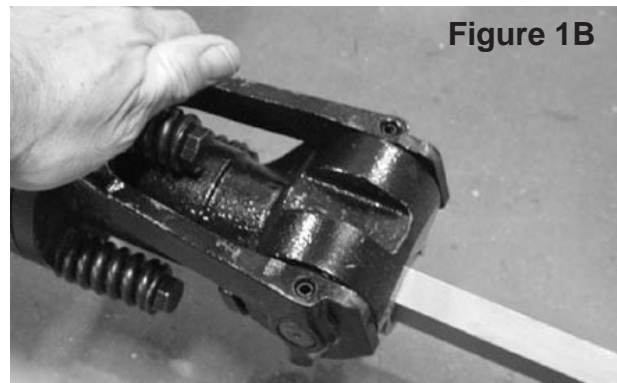

4. Pull the retaining ring back until it touches the spring. See Figure 1B.

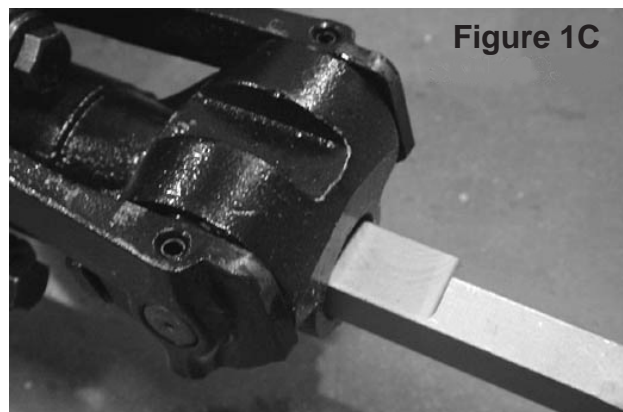

5. When the Chisel is installed, there will be approximately 1-3/4" of play along the flat end of the shank. See Figure 1C. Physically check that the chisel is secure before operating.

With a Collar:

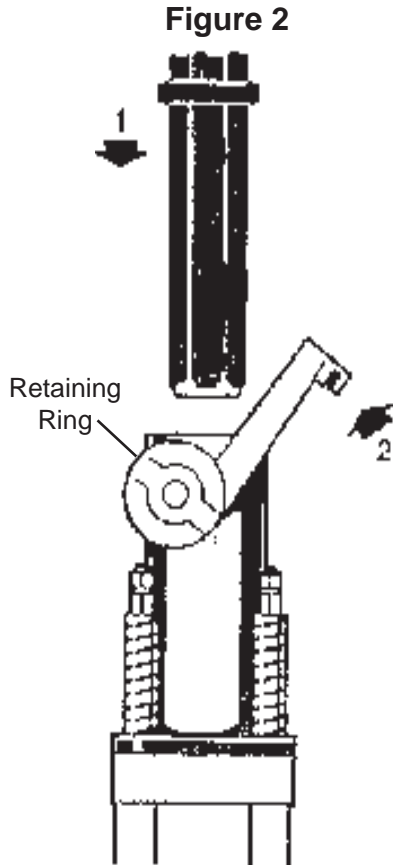

1. Pull the retaining ring open about 30-40° to the second engaging position as shown in Figure 2.
2. Insert the collared chisel.
3. Return the retaining ring to its original position to lock the chisel in place. Physically check that the chisel is secure before operating. The chisel will have approximately 1-3/4" of play, but should not come out when pulled.

OPERATING INSTRUCTIONS



Read the **ENTIRE IMPORTANT SAFETY INFORMATION** section at the beginning of this manual including all text under subheadings therein before set up or use of this product.

Work Piece and Work Area Set Up

1. Designate a work area that is clean and well-lit. The work area must not allow access by children or pets to prevent distraction and injury.
2. Route the power cord along a safe route to reach the work area without creating a tripping hazard or exposing the power cord to possible damage. The power cord must reach the work area with enough extra length to allow free movement while working.
3. Secure loose work pieces using a vise or clamps (not included) to prevent movement while working.
4. There must not be objects, such as utility lines, nearby that will present a hazard while working.

General Operation



TO PREVENT SERIOUS INJURY:

Wear ANSI-approved safety goggles, ear protection, steel-toe boots, and dust mask during use. Keep feet clear of Breaker Hammer. Keep children and animals well clear of the work area.

USE THIS TOOL ONLY WITH A 20 AMP CIRCUIT BREAKER.

This Breaker Hammer may have decreased performance for a brief period at the beginning of each use. This warm-up period lasts approximately 3-5 minutes. This happens because the grease inside the tool may be somewhat thick, preventing the tool from operating at full efficiency while the motor is cold. This is perfectly normal and does not indicate a problem. To help reduce this effect, we recommend storing this equipment in temperatures no lower than 50-60° F.

Only use sharp tipped chisels.

Figure 3

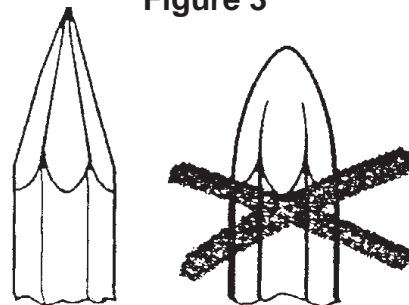

Dull tipped chisels can cause unnecessary chisel movement, resulting in tool wear and possible injury.

Before each use, check the Chisel for dullness, cracks or other damage: Never use a dull or damaged Chisel. See Figure 3.

1. Clearly mark the work area.
2. Plug in the Breaker Hammer.
3. Place the Chisel on the block you will be breaking.

NOTE: Carbon Brushes (51) will wear during use. The Breaker Hammer will cease functioning if the Brushes are worn. This does NOT mean Breaker Hammer is malfunctioning or broken, only that the worn Brushes will need to be replaced with the included Brushes by a qualified technician.

4. Grasp the handles firmly with both hands and depress the Trigger (86).
5. As you break the block into big chunks, release the Trigger (86) and move to other large pieces until all of the larger pieces are broken. Do not try to break up smaller pieces with this tool as it is too powerful and aggressive to control on small pieces.
6. When you are finished, release the Trigger (86) and unplug the cord.
7. Clean, then store indoors out of children's reach.

Important - Replacing Carbon Brushes

THE BREAKER HAMMER WILL CEASE OPERATION ONCE THE CARBON BRUSHES ARE WORN.

Check Carbon Brushes (51) after every hundred (100) hours of regular use. If brush change is necessary, it must be done by a qualified service technician.

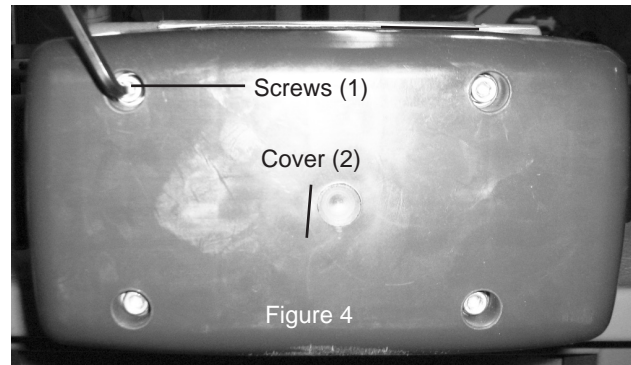

1. Set the Breaker Hammer down on a work bench with the spline axles closer to the top. Use a 5mm Hex Wrench (not included) to loosen the four Screws (1) fastening Cover in place. See Figure 4.

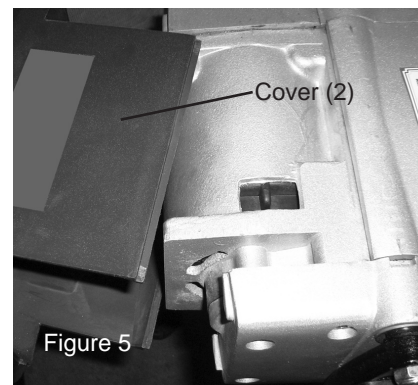

2. Slide Cover off top of Breaker Hammer. See Figure 5.

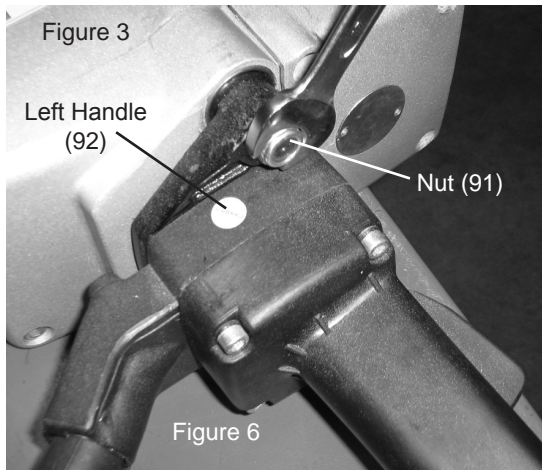

3. Use a Wrench to loosen the Nut (91) holding the Left Handle (92) in place. See Figure 6.

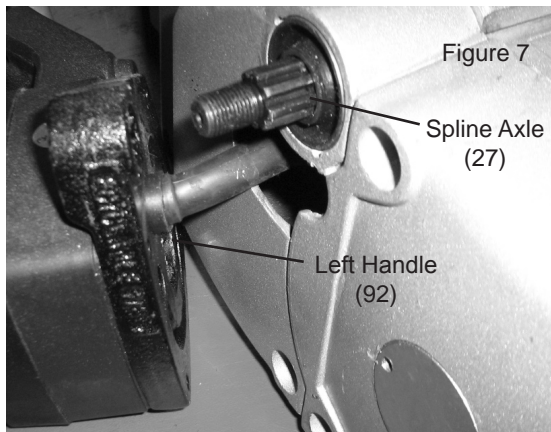

4. **CAUTION:** When removing Left Handle, do not pull too far from Spline Axle (27) Only wiggle loose until partially off. See Figure 7.

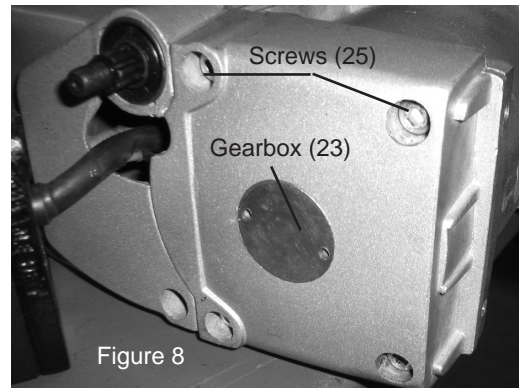

5. Remove the four Screws (25) from the side of the Gearbox 23. See Figure 8.

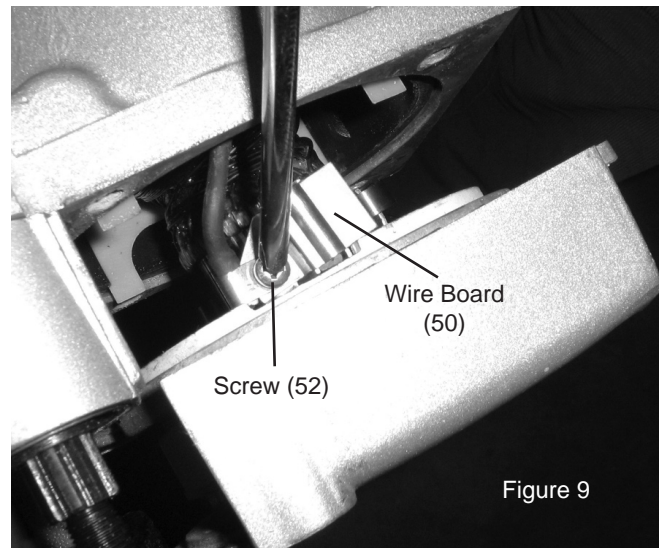

6. Slide Gearbox open so that Wire Board (50) is visible. Use screwdriver (not included) to loosen Screw (52) from Wire Fixing Board. See Figure 9.

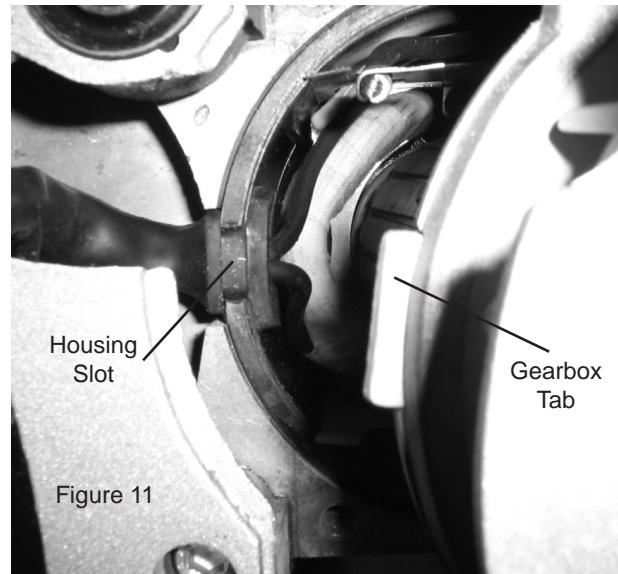
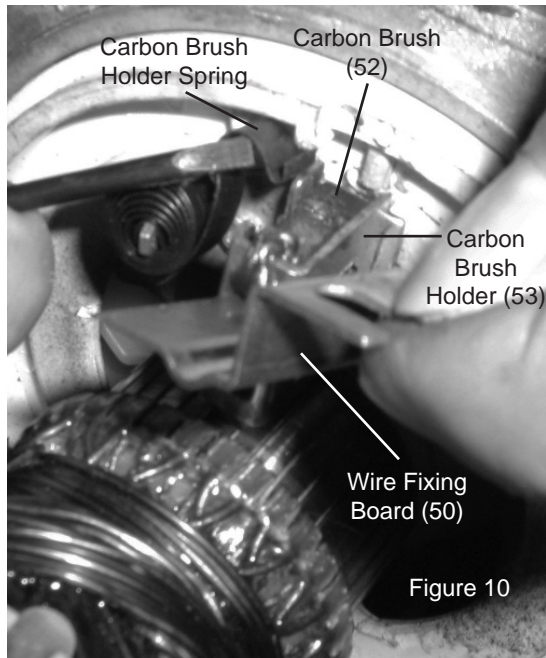

7. Remove the Wire Board from the top of the Carbon Brush Holder (53). Then use tip of flat-edge screwdriver (not included) to carefully pop the Holder's spring off the top of the Carbon Brush (51). See Figure 10.
8. **CAUTION!** The spring must be clear of the Holder lip to remove Carbon Brush.
9. Use the screwdriver to slide the Carbon Brush from the Holder. Then replace with new Carbon Brush.
10. Snap spring back into place and use Screw to replace Wire Board.
11. To better access the second Carbon Brush, turn the Breaker Hammer over. Repeat Steps 7 to 10 to replace second Carbon Brush.

12. Once both Carbon Brushes have been replaced, slide Gearbox shut.
CAUTION: When closing Gearbox, make sure tab along rim of Gearbox aligns with the slot in the housing. See Figure 11.
13. Use the four screws to fasten the Gearbox back into place. Then replace Left Handle and fasten that into place against Gearbox. Replace Cover and fasten it into place using the Screws.

MAINTENANCE AND SERVICING



Procedures not specifically explained in this manual must be performed only by a qualified technician.

⚠️ WARNING

TO PREVENT SERIOUS INJURY

FROM ACCIDENTAL OPERATION:

Release the Trigger and unplug the tool from its electrical outlet before performing any inspection, maintenance, or cleaning procedures.

TO PREVENT SERIOUS INJURY FROM TOOL FAILURE:

Do not use damaged equipment. If abnormal noise or vibration occurs, have the problem corrected before further use.

Cleaning, Maintenance, and Lubrication

- BEFORE EACH USE**, inspect the general condition of the tool. Check for loose hardware, misalignment or binding of moving parts, cracked or broken parts, damaged electrical wiring, and any other condition that may affect its safe operation.
- AFTER USE**, wipe external surfaces of the tool with clean cloth.
- Breaker Hammer will cease operation once Carbon Brushes are worn. Check Brushes every 100 hours and, when necessary, replace them.**
- Wipe tool with a lint-free cloth after each use to remove all dust and grit from the tool.
- Add a drop or two of a lightweight oil to the Trigger assembly area to lubricate the Trigger (86).
- Examine the tool before each use. Make sure the Chisel is sharp and not dull or cracked. Replace worn or broken Chisels with approved replacement Chisels from Harbor Freight Tools.
- Store in temperatures no lower than 50-60° F.
- ⚠️ WARNING! If the supply cord of this power tool is damaged, it must be replaced only by a qualified service technician.**

Troubleshooting

Problem	Possible Causes	Likely Solutions
Tool will not start.	<ol style="list-style-type: none"> 1. Cord not connected. 2. No power at outlet. 3. Tool's thermal reset breaker tripped (if equipped). 4. Internal damage or wear. (Carbon brushes or Trigger, for example.) 	<ol style="list-style-type: none"> 1. Check that cord is plugged in. 2. Check power at outlet. If outlet is unpowered, turn off tool and check circuit breaker. If breaker is tripped, make sure circuit is right capacity for tool and circuit has no other loads. 3. Turn off tool and allow to cool. Press reset button on tool. 4. Have technician service tool.
Tool operates slowly.	Extension cord too long or wire size too small.	Eliminate use of extension cord. If an extension cord is needed, use shorter/heavier gauge cord. See <i>Extension Cords</i> in <i>GROUNDING</i> section.
Performance decreases over time.	<ol style="list-style-type: none"> 1. Accessory dull or damaged. 2. Carbon brushes worn or damaged. 	<ol style="list-style-type: none"> 1. Keep cutting accessories sharp. Replace as needed. 2. Have qualified technician replace brushes.
Excessive noise or rattling.	Internal damage or wear. (Carbon brushes or bearings, for example.)	Have technician service tool.
Overheating.	<ol style="list-style-type: none"> 1. Forcing tool to work too fast. 2. Accessory misaligned. 3. Accessory dull or damaged. 4. Blocked motor housing vents. 5. Motor being strained by long or small diameter extension cord. 	<ol style="list-style-type: none"> 1. Allow tool to work at its own rate. 2. Check and correct accessory to fence and/or table alignment. 3. Keep cutting accessories sharp. Replace as needed. 4. Wear ANSI-approved safety goggles and NIOSH-approved dust mask/respirator while blowing dust out of motor using compressed air. 5. Eliminate use of extension cord. If an extension cord is needed, use one with the proper diameter for its length and load. See <i>Extension Cords</i> in <i>GROUNDING</i> section.
 Follow all safety precautions whenever diagnosing or servicing the tool. Disconnect power supply before service.		

PLEASE READ THE FOLLOWING CAREFULLY

THE MANUFACTURER AND/OR DISTRIBUTOR HAS PROVIDED THE PARTS LIST AND ASSEMBLY DIAGRAM IN THIS MANUAL AS A REFERENCE TOOL ONLY. NEITHER THE MANUFACTURER OR DISTRIBUTOR MAKES ANY REPRESENTATION OR WARRANTY OF ANY KIND TO THE BUYER THAT HE OR SHE IS QUALIFIED TO MAKE ANY REPAIRS TO THE PRODUCT, OR THAT HE OR SHE IS QUALIFIED TO REPLACE ANY PARTS OF THE PRODUCT. IN FACT, THE MANUFACTURER AND/OR DISTRIBUTOR EXPRESSLY STATES THAT ALL REPAIRS AND PARTS REPLACEMENTS SHOULD BE UNDERTAKEN BY CERTIFIED AND LICENSED TECHNICIANS, AND NOT BY THE BUYER. THE BUYER ASSUMES ALL RISK AND LIABILITY ARISING OUT OF HIS OR HER REPAIRS TO THE ORIGINAL PRODUCT OR REPLACEMENT PARTS THERETO, OR ARISING OUT OF HIS OR HER INSTALLATION OF REPLACEMENT PARTS THERETO.

PARTS LIST

Part	Description	Qty	Part	Description	Qty	Part	Description	Qty
1	Screw	4	33	Fixing Sheath	1	65	Fixing Sheath	1
2	Cover	1	34	Hammer Cylinder	1	66	Sheath	1
3	Crankshaft Box	1	35**	O-ring	2	67	Crankshaft	2
4	Connecting Rod	1	36	Clamp Base	1	68*	Bearing	1
5**	Fixing Ring	1	37**	Spring	3	69**	Seal Washer	1
6	Piston	1	38	Washer	3	70**	Seal Cover	1
7	Spring Hammer	1	39	Nut	3	71	Right-down Cover	4
8**	O-ring	1	40**	Rubber Washer	2	72	Screw	4
9	Cylinder Box	1	41	Pin	1	73	Screw	1
10	Screw	4	42	Clamp Frame	1	74	Right Balancing	2
11*	Bearing	1	43	Roll Pin	2	75	Nut	1
12	Pin	1	44	Shell	1	76	Switch Box	1
13	Felt Washer	1	45	Wire Protector	1	77	Switch	1
14	Bearing	1	46	Stator	1	78	Switch Sheath	2
15	Axle	2	47	Stator Compressor	2	79	Screw	1
16	Bearing Assembly	1	48	Screw	2	80	Switch Box Cover	1
17	Gear	1	49	Rotor	1	81	Capacitor	1
18*	Bearing	1	50	Wire Board	2	82	Terminal	1
19	Adjust Washer	1	51 ¹	Carbon Brush	4	83	Cable Clip	2
20	Snap Ring	2	52	Screw	2	84	Screw	1
21	Gear	1	53	Carbon Brush Holder	2	85	Cable	1
22**	Seal Spacer	1	54	Screw	2	86	Trigger	1
23	Gear Box	1	55	Wind Lead Ring	1	87	Switch Knob	1
24	Shock Absorber	2	56	Vane	1	88	Roll Pin	1
25	Screw	9	57	Tail Cover	1	89	Right Handle	4
26	Spline Assembly	2	58	Screw	9	90	Screw	2
27	Spline Axle	1	59*	Bearing	1	91	Nut	1
28	Nut	2	60	Nut	1	92	Left Handle	1
29	Left Balancing	1	61	Rear Cover	1	93	Screw	4
30	Fixing Sheath Washer	1	62	Washer	2	94*	Bearing Kit	
31	Fixing Sheath	1	63**	Rubber Seal	1	95**	Seal Kit	
32**	Spring	1	64	Bearing	1	96	Bushing	1

#51¹ - Two Carbon Brushes are installed; two replacement Brushes are included.

Parts with one or two asterisks are not available individually. You must purchase the parts kits.

#94* - Bearing Kit includes part numbers 11*, 18*, 59*, 68*

#95** - Seal Kit includes part numbers 5**, 8**, 22**, 32**, 35**, 37**, 40**, 63**, 69**, 70**

ASSEMBLY DRAWING

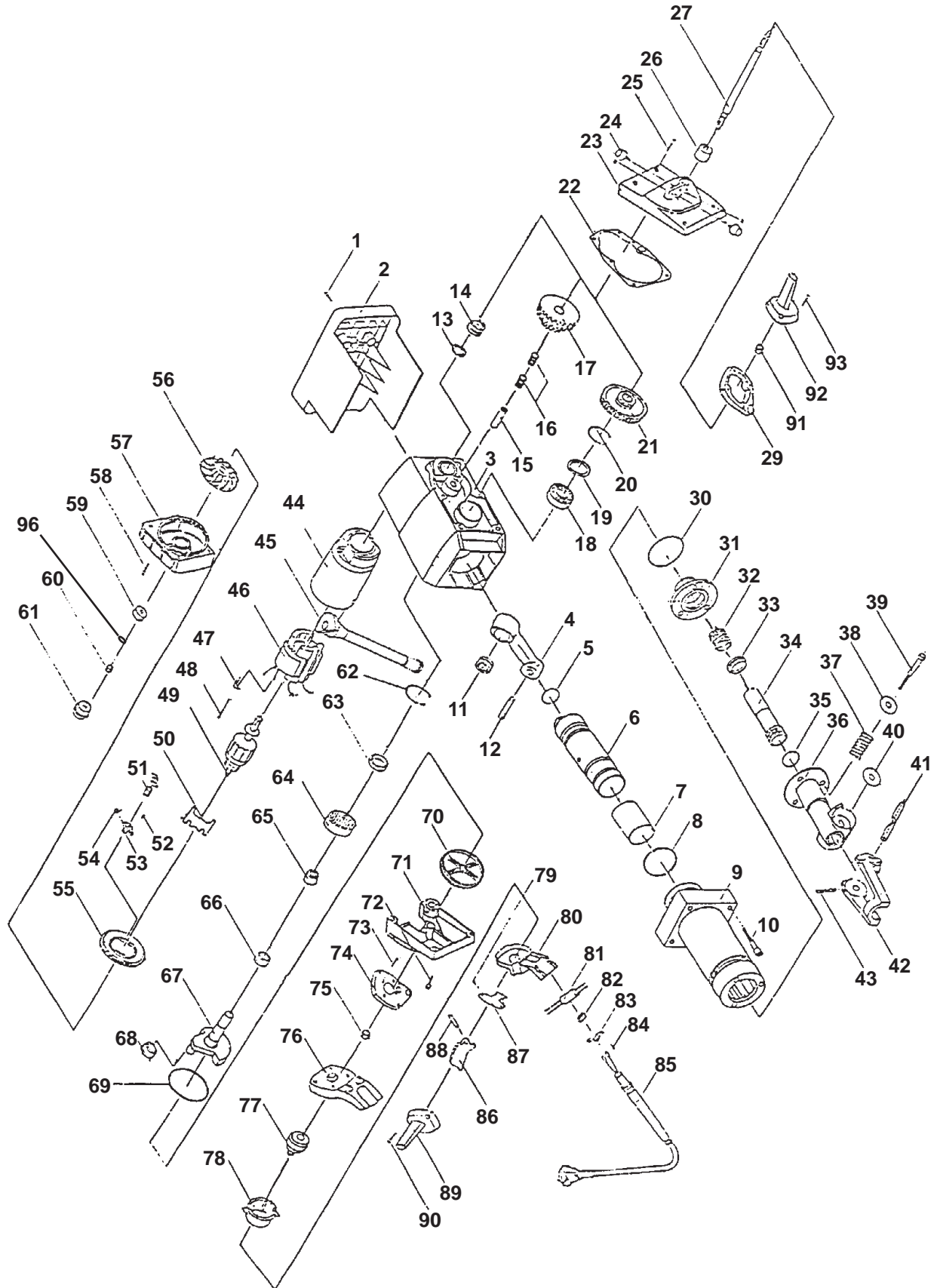

Record Product's Serial Number Here:

Note: If product has no serial number, record month and year of purchase instead.

Note: Some parts are listed and shown for illustration purposes only, and are not available individually as replacement parts.

LIMITED 90 DAY WARRANTY

Harbor Freight Tools Co. makes every effort to assure that its products meet high quality and durability standards, and warrants to the original purchaser that this product is free from defects in materials and workmanship for the period of 90 days from the date of purchase. This warranty does not apply to damage due directly or indirectly, to misuse, abuse, negligence or accidents, repairs or alterations outside our facilities, criminal activity, improper installation, normal wear and tear, or to lack of maintenance. We shall in no event be liable for death, injuries to persons or property, or for incidental, contingent, special or consequential damages arising from the use of our product. Some states do not allow the exclusion or limitation of incidental or consequential damages, so the above limitation of exclusion may not apply to you. THIS WARRANTY IS EXPRESSLY IN LIEU OF ALL OTHER WARRANTIES, EXPRESS OR IMPLIED, INCLUDING THE WARRANTIES OF MERCHANTABILITY AND FITNESS.

To take advantage of this warranty, the product or part must be returned to us with transportation charges prepaid. Proof of purchase date and an explanation of the complaint must accompany the merchandise. If our inspection verifies the defect, we will either repair or replace the product at our election or we may elect to refund the purchase price if we cannot readily and quickly provide you with a replacement. We will return repaired products at our expense, but if we determine there is no defect, or that the defect resulted from causes not within the scope of our warranty, then you must bear the cost of returning the product.

This warranty gives you specific legal rights and you may also have other rights which vary from state to state.

**3491 Mission Oaks Blvd. • PO Box 6009
Camarillo, CA 93011 • (800) 444-3353**

Free Manuals Download Website

<http://myh66.com>

<http://usermanuals.us>

<http://www.somanuals.com>

<http://www.4manuals.cc>

<http://www.manual-lib.com>

<http://www.404manual.com>

<http://www.luxmanual.com>

<http://aubethermostatmanual.com>

Golf course search by state

<http://golfingnear.com>

Email search by domain

<http://emailbydomain.com>

Auto manuals search

<http://auto.somanuals.com>

TV manuals search

<http://tv.somanuals.com>