

Speaker Layout

Figure 1

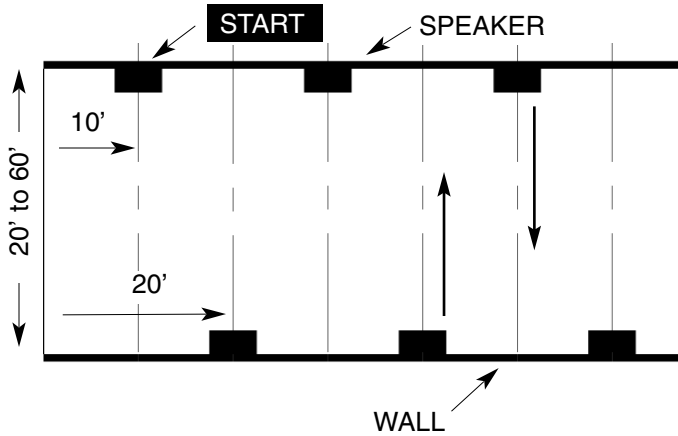

The layout of the speakers should be planned prior to installation. Because wall baffle speakers are designed to project forward, it is best to aim them in the same direction, as this provides for both greater coverage and clarity. You can use the building's roof pillars or other available supports for mounting the wall baffles. In some cases, it may be necessary to mount the wall baffles on opposing walls. In these cases, the speakers will project sound in opposing directions.

HALLWAY/ROOM - Wall baffle speakers work well with rooms and hallways that are 20' to 60' wide. Layout starts at one end of the hallway or room. The first speaker should be installed 10' from the end of the hallway or room. The next speaker on that wall should be installed 20' from the first speaker, as should any additional speakers required to cover the length of the hallway or room.

Figure 2

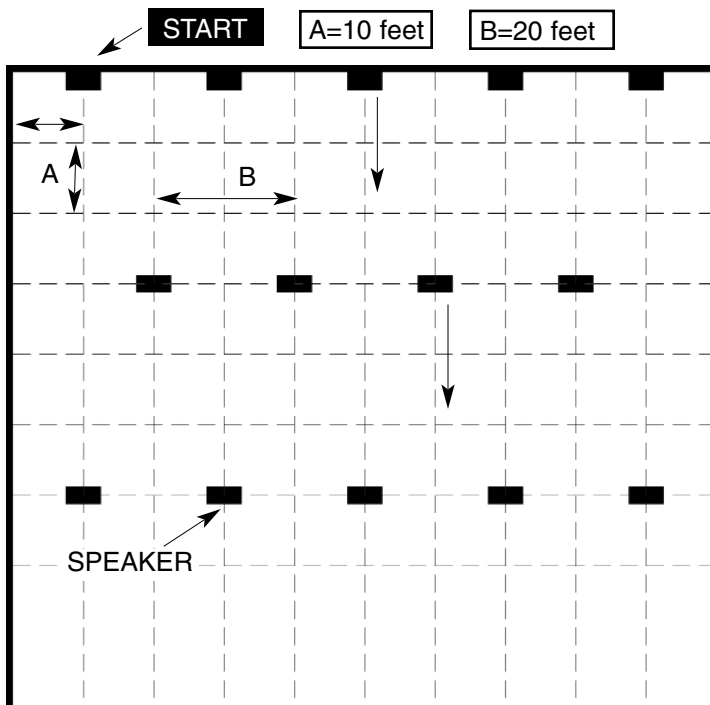

The first speaker on the opposing wall should be installed 20' from the end of the hallway or room, thereby staggering the speakers. Each additional speaker should also be installed 20' apart from the previous one. **See Figure 1.**

OPEN AREA - The number of speakers needed to cover an open area and the layout of those speakers is contingent upon the availability of suitable mounting points in the area to be covered.

Layout starts in one corner of the room. The first speaker should be installed 10' from the wall with each additional speaker in the first row installed in increments of 20' from the first. Based on **Figure 2**, install the next row of speakers 30' from the first row and 20' from the wall with increments of 20' between each speaker. The third row would follow the example of the first and each additional row would continue this pattern of alternating rows until the whole area is covered.

Speaker Installation

STEP 1 - Mark the point from which to hang the speaker. Drill an appropriately sized hole in the wall and insert an anchor. Drive the screw into the anchor leaving enough of the screw exposed from which to hang the speaker on. **See Figure 3.**

NOTE: Wall baffle speakers should be installed between 8 and 16 feet from the floor depending upon need.

STEP 2 - Make the electrical connections using the 2 screw terminals on the WB1EZ. The recommended amplifier connections are:

- (+) **70V** terminal - **70V HOT**
- (-) **COM** terminal - **70V COMMON**

NOTE: The speaker will also work perfectly well with these connections reversed. However, it is important to be consistent in the wiring of the speakers in the system. If adjacent speakers have reversed wiring connections, they will tend to cancel each other's bass response, thereby diminishing the sound quality.

STEP 3 - If it is necessary to adjust the volume, insert a thin, flat blade screwdriver into the access hole at the bottom of the wall baffle, then turn the volume control clockwise (as viewed from the bottom of the baffle) to increase the volume. To reduce the volume, simply turn the volume control in a counterclockwise motion. **See Figure 4.**

Figure 3

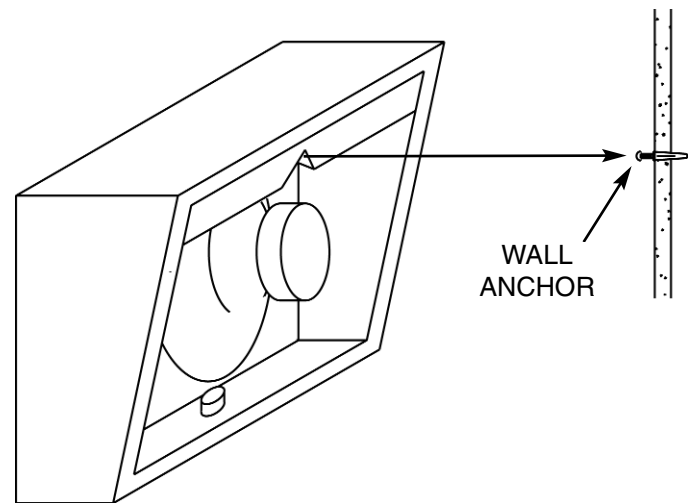
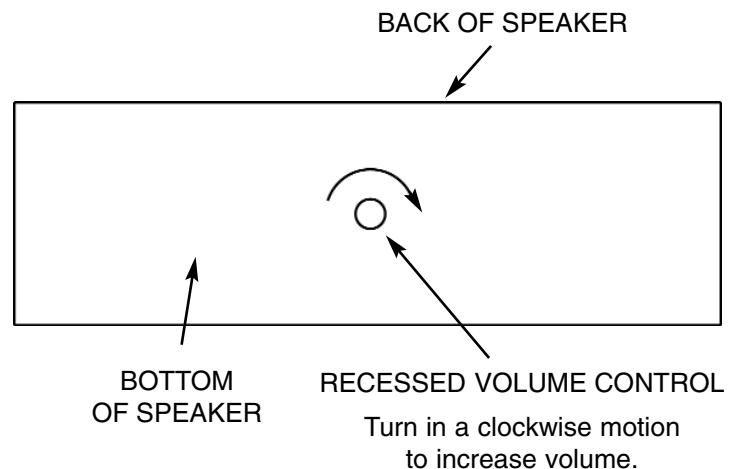

Figure 4



BOGEN[®]
COMMUNICATIONS, INC.

50 Spring Street, Ramsey, NJ 07446
Tel. (201) 934-8500 / Fax: (201) 934-9832
www.bogen.com

54-5069-01 Printed in Korea 9904
© 1999 Bogen Communications Inc. All rights reserved.
Specifications subject to change without notice.

Free Manuals Download Website

<http://myh66.com>

<http://usermanuals.us>

<http://www.somanuals.com>

<http://www.4manuals.cc>

<http://www.manual-lib.com>

<http://www.404manual.com>

<http://www.luxmanual.com>

<http://aubethermostatmanual.com>

Golf course search by state

<http://golfingnear.com>

Email search by domain

<http://emailbydomain.com>

Auto manuals search

<http://auto.somanuals.com>

TV manuals search

<http://tv.somanuals.com>