

BOSTITCH®

D16-2AD BOXLOK STAPLER

STAPLE SIZES: SW7437 7/16 SW7437 5/8 SW7437 3/4
 SW9040 5/8 SW9040 3/4 SW9040 7/8

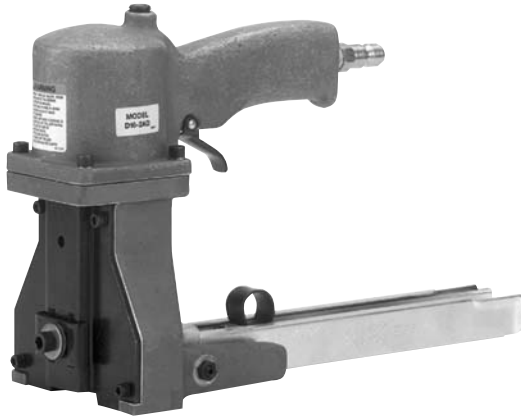

OPERATION and MAINTENANCE MANUAL

- ⚠WARNING:** BEFORE OPERATING THIS TOOL, ALL OPERATORS SHOULD STUDY THIS MANUAL TO UNDERSTAND AND FOLLOW THE SAFETY WARNINGS AND INSTRUCTIONS. KEEP THESE INSTRUCTIONS WITH THE TOOL FOR FUTURE REFERENCE. IF YOU HAVE ANY QUESTIONS, CONTACT YOUR BOSTITCH REPRESENTATIVE OR DISTRIBUTOR.
- ⚠WARNING:** DO NOT USE SUPPLY SOURCES WHICH CAN POTENTIALLY EXCEED 80 PSIG (5.7 KG/CM²) AS TOOL MAY BURST, POSSIBLY CAUSING INJURY.
- ⚠WARNING:** WHEN AIR SUPPLY IS CONNECTED KEEP HANDS AND BODY AWAY FROM STAPLE DISCHARGE AREA AT ALL TIMES. DO NOT FIRE THE TOOL WITHOUT STAPLING INTO MATERIAL.
- ⚠WARNING:** THE CONNECTOR ON THE TOOL MUST NOT HOLD PRESSURE WHEN AIR SUPPLY IS DISCONNECTED. IF A WRONG FITTING IS USED, THE TOOL CAN REMAIN CHARGED WITH AIR AFTER DISCONNECTING AND THUS WILL BE ABLE TO DRIVE A STAPLE EVEN AFTER THE AIR LINE IS DISCONNECTED POSSIBLY CAUSING INJURY.
- ⚠WARNING:** DO NOT PULL TRIGGER OR DEPRESS CONTACT ARM WHILE CONNECTED TO THE AIR SUPPLY AS THE TOOL MAY CYCLE, POSSIBLY CAUSING INJURY.
- ⚠WARNING:** DO NOT USE OXYGEN, COMBUSTIBLE GASES, OR BOTTLED GASES AS A POWER SOURCE FOR THIS TOOL AS TOOL MAY EXPLODE, POSSIBLY CAUSING INJURY.
- ⚠WARNING:** FAILURE TO OBSERVE ANY OF THESE WARNINGS MAY RESULT IN INJURY.

BOSTITCH®
Stanley Fastening Systems

BSA981SREVE 9/03

AIR SUPPLY AND CONNECTION

⚠WARNING: Do not use oxygen, combustible gases, or bottled gases as a power source for this tool as tool may explode, possibly causing injury.

⚠WARNING: Do not use supply sources which can potentially exceed 80 P.S.I.G. (5.6 kg/cm²) as tool may burst, possibly causing injury.

⚠WARNING: The connector on the tool must not hold pressure when air supply is disconnected. If a wrong fitting is used, the tool can remain charged with air after disconnecting and thus will be able to drive a staple even after the air line is disconnected possibly causing injury.

Clean, dry air as provided by the proper filter-regulator-lubricator is mandatory for satisfactory operation of the tool. For proper functioning and lubrication, install this trio unit within 15 feet (4.8 meters) of the tool. Check periodically for cleanliness and oil usage. Use only Mobil Velocite #10 or equivalent oil. DO NOT use a detergent oil.

OPERATING PRESSURE

40 to 60 p.s.i.g. (2.8 to 4.2 kg/cm²). Select the operating pressure within this range for best fastener performance.

DO NOT EXCEED THIS RECOMMENDED OPERATING PRESSURE.

All hoses, pipes and pipe fittings must have a 3/8" (9.5 mm) minimum inside diameter. Hose fittings must have a 9/32" (7.1mm) minimum inside diameter.

AIR CONSUMPTION

Air requirements will vary with operating speed and the type of material to be fastened. Do not use more air pressure than required for the job. Air pressure in excess of the amount required to provide adequate fastening wastes compressed air and may result in damage to equipment.

After all air connections are made, check for leaks.

CHOICE OF STAPLE SIZE

When letter "A" on D16112 clamp is in upper left hand corner refer to below listed chart as a guide for establishing proper staple leg length and approximate clincher depth setting. NOTE: When D16112 clamp is rotated 180° and letter "B" appears in the upper left hand corner the range of clincher depth settings is lowered 1/32" (.79mm).

⚠WARNING: EYE PROTECTION WHICH CONFORMS TO ANSI SPECIFICATIONS AND PROVIDES PROTECTION AGAINST FLYING PARTICLES BOTH FROM THE FRONT AND SIDE SHOULD ALWAYS BE WORN BY THE OPERATOR AND OTHERS IN THE WORK AREA WHEN LOADING, OPERATING OR SERVICING THIS TOOL. EYE PROTECTION IS REQUIRED TO GUARD AGAINST FLYING FASTENERS AND DEBRIS, WHICH COULD CAUSE SEVERE EYE INJURY.



THE EMPLOYER AND/OR USER MUST ENSURE THAT PROPER EYE PROTECTION IS WORN. EYE PROTECTION EQUIPMENT MUST CONFORM TO THE REQUIREMENTS OF THE AMERICAN NATIONAL STANDARDS INSTITUTE, ANSI Z87.1 AND PROVIDE BOTH FRONTAL AND SIDE PROTECTION. NOTE: NON-SIDE SHIELDED SPECTACLES AND FACE SHIELDS ALONE DO NOT PROVIDE ADEQUATE PROTECTION.



CAUTION: ADDITIONAL SAFETY PROTECTION WILL BE REQUIRED IN SOME ENVIRONMENTS. FOR EXAMPLE, THE WORKING AREA MAY INCLUDE EXPOSURE TO NOISE LEVEL WHICH CAN LEAD TO HEARING DAMAGE. THE EMPLOYER AND USER MUST ENSURE THAT ANY NECESSARY HEARING PROTECTION IS PROVIDED AND USED BY THE OPERATOR AND OTHERS IN THE WORK AREA. SOME ENVIRONMENTS WILL REQUIRE THE USE OF HEAD PROTECTION EQUIPMENT. WHEN REQUIRED, THE EMPLOYER AND USER MUST ENSURE THAT HEAD PROTECTION CONFORMING TO ANSI Z89.1 IS USED.

TO LOAD

When loading tool: 1.) Never place a hand or any part of body in fastener discharge area of tool; 2.) Never point tool at anyone; 3.) Do not pull the trigger or depress the trip as accidental actuation may occur, possibly causing injury.

Pull Pusher to back of magazine and turn over rear as far as it will go.

Place 2 sticks of SW7437 or SW9040 staples in channel.

Swing pusher into place against staples. Do not let it slip and strike staples. This may deform some staples, and cause poor feeding.

⚠WARNING:**TO PREVENT ACCIDENTAL INJURIES:**

- **Never place a hand or any other part of the body in staple discharge area of tool while the air supply is connected.**
- **Never point the tool at anyone else.**
- **Never engage in horseplay.**
- **Never pull the trigger unless nose is directed at the work.**
- **Always handle the tool with care.**
- **Do not pull the trigger while loading the tool.**

TO OPERATE

SHUT OFF AIR SUPPLY BEFORE MAKING ADJUSTMENT, REMOVING CLOGGED STAPLES OR SERVICING.

To operate machine, grasp handle. Position machine on box placing directly over the seam between flaps and in line with desired staple location. Squeeze trigger and release completely before moving machine. Move machine to each staple position and repeat. Strongest closure requires end staples close to end of box, approximately 1" (25.4mm). Be sure staples penetrate inner flaps. Check staple clinching in sample of box board, such as that being used. Adjustment for depth of penetration is easy and full advantage should be taken. Clincher adjusting clamp settings as listed in chart are offered only as a guide and may have to be slightly modified.

MAINTENANCE

⚠WARNING:

Always disconnect air supply: 1.) Before making adjustments; 2.) When servicing the tool; 3.) When clearing a jam; 4.) When tool is not in use; 5.) When moving to a different work area, as accidental actuation may occur, possibly causing injury.

⚠WARNING:

When working on air tools note the warnings in this manual and use extra care when evaluating problem tools.

Specify the part number when ordering replacement parts. Do not order by description. Do not wrench, twist or force parts during servicing, as damage may result.

Check screws periodically for tightness. Observe caution against stripping threads when tightening. When the tool is disassembled, clean thoroughly. Lubricate all moving parts after cleaning. Apply "Magnalube-G" to O-rings. Examine all parts for wear during servicing so that replacement parts can be ordered in advance of trouble.

LUBRICATION

Frequent, but not excessive, lubrication is required for best performance. Oil added through the air line connection will lubricate the internal parts. Use BOSTITCH Air Tool Lubricant, Mobil Velocite #10, or equivalent. Do not use detergent oil or additives as these lubricants will cause accelerated wear to the seals and bumpers in the tool, resulting in poor tool performance and frequent tool maintenance.

If no airline lubricator is used, add oil during use into the air fitting on the tool once or twice a day. Only a few drops of oil at a time is necessary. Too much oil will only collect inside the tool and will be noticeable in the exhaust cycle.

CAUTION: Do not store tools in a cold weather environment to prevent frost or ice formation on the tools operating valves and mechanisms that could cause tool failure.

NOTE: Some commercial air line drying liquids are harmful to "O"-rings and seals – do not use these low temperature air dryers without checking compatibility.

FILTER:

Dirt and water in the air supply are major causes of wear in pneumatic tools. A filter will help to get the best performance and minimum wear from the tool. The filter must have adequate flow capacity for the specific installation. The filter has to be kept clean to be effective in providing clean compressed air to the tool. Consult the manufacturer's instructions on proper maintenance of your filter. A dirty and clogged filter will cause a pressure drop which will reduce the tool's performance.

REGULATOR:

A pressure regulator with an operating pressure of 0 - 125 p.s.i. (0 - 8.79 KG/CM²) is required to control the operating pressure for safe operation of this tool. Do not connect this tool to air pressure which can potentially exceed 200 p.s.i. (14 KG/CM²) as tool may fracture or burst, possibly causing injury.

1. Apply LOCTITE 242 to screw thread before assembling hanger to tool.
2. Use a swivel type hook on the counterbalance used to suspend this tool.

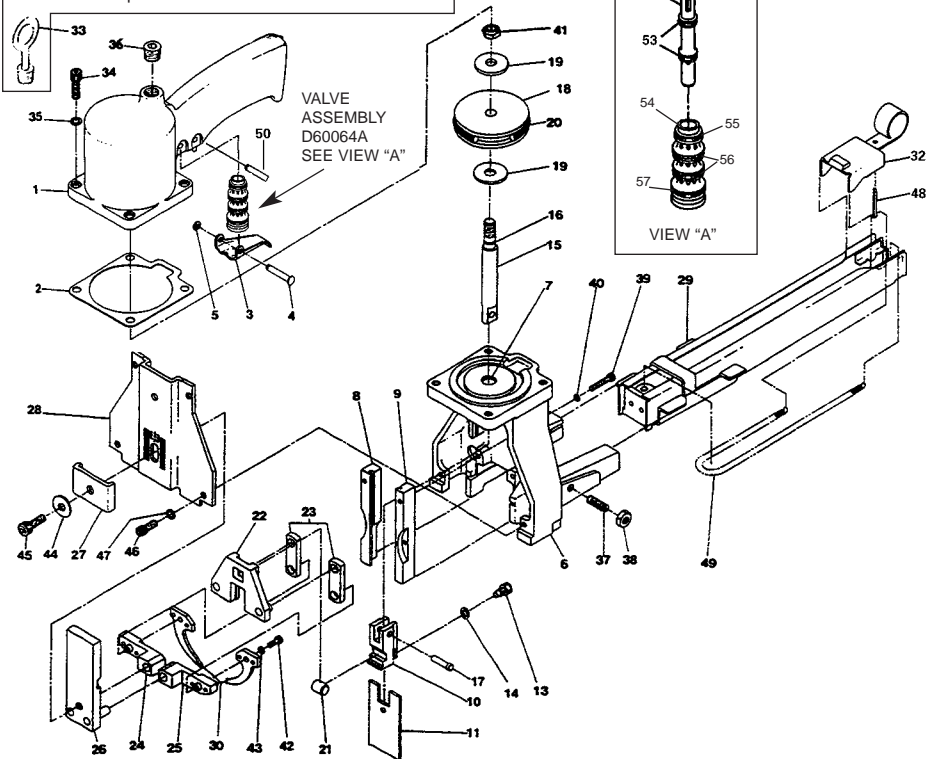

ITEM NO.	PART NO.	DESCRIPTION	ITEM NO.	PART NO.	DESCRIPTION
1.	121830	Cylinder	26.	D16111A	Clincher Adj. Plate
2.	D16243	Cylinder Gasket	27.	D16112	Clincher Adj. Clamp
3.	T20111	Trigger	28.	D16114	Front Plate
4.	T20018	Trigger Pivot Pin	32.	D16149A	Pusher Assembly
5.	T20049	Trigger Pin Retaining Ring	34.	UA4814.1	1/4-20 x 7/8 Soc. Hd. Cap Screw
6.	D16163A	Frame	35.	LW14.2	1/4 Lock Washer
7.	85014	"O" Ring	36.	UA9607	1/4 Pipe Plug
8.	D16168	Driver Guide L.H.	37.	UA4816.12	1/4-20 x 1" Cone Pt. Set Screw
9.	D16167	Driver Guide R.H.	38.	HN1420.2	1/4-20 Hex Jam Nut
10.	D16179	Driver Block	39.	UA2810	#8-32 x 5/8" Soc. Hd. Cap Screw
13.	UA4006.2	Driver Retaining Screw	40.	LW8	#8 Lock Washer
14.	D16327	Retaining Screw Spacer	41.	HN3824.4	3/8-24 Elastic Stop Nut
15.	D16180	Piston Rod	42.	UA2808.1	#8-32 x 1/2" Soc. Hd. Cap Screw
16.	85012	"O" Ring	43.	LW8	#8 Lock Washer
17.	D16185	Driver Block Pin	44.	PW516.4	Washer
18.	D14227B	Piston	45.	UA5812.3	5/16-18 x 3/4" Soc. Hd. Cap Screw
19.	D16146	Piston Washer	46.	UA 3808.8	#10-24 x 1/2" Soc. Hd. Cap Screw
20.	85016	"O" Ring			
21.	D16183	Escapement Roller			
22.	D16184A	Clincher Link Plate			
23.	D14130	Clincher Link			
24.	D14132A	Clincher Lever L.H.			
25.	D14133A	Clincher Lever R.H.			

ITEM NO.	PART NO.	DESCRIPTION
47.	LW10	#10 Lock Washer
48.	UP2912.3	3/32 x 3/4" Cotter Pin
49.	D14164	Pusher Spring
50.	UB2814.2	Pin, Spring .094 x .88
51.	D60054	Spring, Valve

ITEM NO.	PART NO.	DESCRIPTION
52.	D60009	Valve Stem
53.	851201	O-Ring .301 x .070
54.	D60008	Valve Body
55.	86458	O-Ring 1/16"x 1/2" ID
56.	86998	O-Ring 1/16"x 9/16" ID
57.	86459	O-Ring 1/16"x 5/8" ID

VARIABLE PARTS

ITEM NO.	DESCRIPTION	STANDARD PARTS	OPTIONAL PARTS
11.	Driver	D16170 (long)	D16178 (short)
30.	Clincher	D16124 (deep)	D16124B (deep pointed) D14135 (shallow)
33.	C' Balance Hanger		D16106A
29.	Magazine Assembly	D16169A [5/8" (15.9mm) 3/4" (19.1mm) and 7/8" (22.2mm) staples]	D16164A [7/16" (11.1mm) 5/8" (15.9mm) and 3/4" (19.1mm) staples]

D14135 CLINCHERS

Approx. Clincher Adjusting

Clamp Setting	6	5	4	3	2	1
(2) A Board-Blind				5/8" 15.9mm Leg		
(2) A Board-Through					3/4" 19.1mm Leg	
(2) B Board-Blind		7/16" 11.1mm Leg				
(2) B Board-Through			5/8" 15.9mm Leg			
(2) C Board-Blind			7/16" 11.1mm Leg			
(2) C Board-Through			5/8" 15.9mm Leg			

D16124 DEEP CLINCHERS

Approx. Clincher Adjusting

Clamp Setting	6	5	4	3	2	1
(2) A Board-Through					3/4" 19.1mm Leg	
(2) AB Board-Blind					3/4" 19.1mm Leg	
(2) AB Board-Through						7/8" 22.2mm Leg

D14135 clinchers are for shallow penetration as in single wall board and will clinch inside board without damage to contents. D16124 clinchers are for deep penetration as in double wall board.

CAUTION: WHEN USING DEEP PENETRATION CLINCHERS, IT MAY BE NECESSARY TO USE A FILLER TO PREVENT DAMAGE TO MERCHANDISE. D16124 CLINCHERS MAY ALSO BE USED FOR STAPLING THROUGH SINGLE WALL BOARD PROVIDED A FILLER IS USED TO PREVENT DAMAGE TO CONTENTS OR CLINCHERS.

To obtain maximum efficiency from the staple closure, it is important that the staple be clinched properly. Proper clinching for any thickness board may be obtained by adjusting the clincher setting with staples of proper leg length.

Use the proper length staples for the thickness of work to be stapled, otherwise unnecessary pressure is exerted and staple crowns and legs will be distorted, or the clinch will be too loose.



Staple driven completely through two thicknesses of corrugated board and clinched on underside.



Staple clinched "blind" when desired, in two thicknesses of corrugated board.

CLINCHER ADJUSTMENT:

WARNING: Always disconnect air supply; 1.) Before making adjustments; 2.) When servicing the tool; 3.) When clearing a jam; 4.) When tool is not in use; 5.) When moving to a different work area, as accidental actuation may occur, possibly causing injury.

WARNING: When working on air tools note the warnings in this manual and use extra care when evaluating problem tools.

Clincher adjustment for depth of penetration is obtained by loosening the clincher adjusting clamp screw on front of machine and moving it up or down. When in its highest position, the clinchers are set for the shallowest staple penetration. Lowering the clinchers increases the penetration. After establishing the setting, tighten adjustment screw.

NOTE: The D16-2AD is equipped with a driver to countersink the crown of the staple below the surface of the box. The shorter driver, available on order, will allow the crown of the staple to rest on the top of the box.

CLINCHER REPLACEMENT:

⚠WARNING: Always disconnect air supply: 1.) Before making adjustments; 2.) When servicing the tool; 3.) When clearing a jam; 4.) When tool is not in use; 5.) When moving to a different work area, as accidental actuation may occur, possibly causing injury.

⚠WARNING: When working on air tools note the warnings in this manual and use extra care when evaluating problem tools.

1. Loosen the clincher adjusting clamp screw.
2. Slide the clincher adjusting clamp to the highest position. Retighten clamp screw. The clincher screws will be aligned with and visible through the 2 round holes in the back of the machine frame. Insert a socket screw wrench to loosen and remove screw holding clincher.
3. Grasp the clinchers by hand or with pliers and lift off the anchor dowels.
4. To assemble new clincher and screw, clean parts thoroughly. Degrease threads with Loctite Safety Solvent #75559; apply Loctite Grade 222 to screw threads and assemble. Refer to Loctite's instructions. Tighten screw firmly.
5. Re-adjust the clincher adjusting clamp to the desired setting and tighten.

DRIVER REPLACEMENT:

⚠WARNING: Always disconnect air supply: 1.) Before making adjustments; 2.) When servicing the tool; 3.) When clearing a jam; 4.) When tool is not in use; 5.) When moving to a different work area, as accidental actuation may occur, possibly causing injury.

⚠WARNING: When working on air tools note the warnings in this manual and use extra care when evaluating problem tools.

1. Remove the magazine.
2. Remove the driver retaining screw, Item 13. Driver may now be removed from the housing.

MAGAZINE REPLACEMENT:

⚠WARNING: Always disconnect air supply: 1.) Before making adjustments; 2.) When servicing the tool; 3.) When clearing a jam; 4.) When tool is not in use; 5.) When moving to a different work area, as accidental actuation may occur, possibly causing injury.

⚠WARNING: When working on air tools note the warnings in this manual and use extra care when evaluating problem tools.

1. Remove staples from magazine.
2. Loosen the two magazine binding screws and nuts.
3. Pull magazine out of engagement with the frame.
4. Insert new magazine making sure the front edge contacts the rear of driver guides. Centralize magazine in driver guides with binding screws. Tighten the magazine binding screw and nut so that magazine is securely held.

CAUTION: DO NOT TIGHTEN THE MAGAZINE BINDING SCREW EXCESSIVELY AS TOO MUCH PRESSURE WILL DAMAGE THE MAGAZINE.

DRIVER BLOCK PIN REPLACEMENT:

⚠WARNING: Always disconnect air supply: 1.) Before making adjustments; 2.) When servicing the tool; 3.) When clearing a jam; 4.) When tool is not in use; 5.) When moving to a different work area, as accidental actuation may occur, possibly causing injury.

⚠WARNING: When working on air tools note the warnings in this manual and use extra care when evaluating problem tools.

1. Remove piston rod and driver block assembly from machine.
2. Remove as much flare on end of driver block pin as possible.
3. Use a rod smaller than pin diameter as a punch and drive pin free.
4. To reassemble, insert new driver block pin thru driver block and piston rod. Support driver block pin on head and flare opposite end. Only a slight flare of approx. .020 greater than pin diameter is required to retain pin and provide proper linear movement of pin in assembly.

Free Manuals Download Website

<http://myh66.com>

<http://usermanuals.us>

<http://www.somanuals.com>

<http://www.4manuals.cc>

<http://www.manual-lib.com>

<http://www.404manual.com>

<http://www.luxmanual.com>

<http://aubethermostatmanual.com>

Golf course search by state

<http://golfingnear.com>

Email search by domain

<http://emailbydomain.com>

Auto manuals search

<http://auto.somanuals.com>

TV manuals search

<http://tv.somanuals.com>