

Installation Instructions

393U

Series D

GAS FIRED FORCED AIR FURNACE

bryant

39393D2
Rev. 3/17/65

The Bryant Model 393 forced air, gas-fired furnace may be installed as an

1. Upflow Furnace
2. Counter-Flow Furnace
(except sizes 175 and 200)
3. Basement Furnace

This instruction contains complete procedures for installing the unit as an **Upflow Furnace**.

When the furnace is used as a counter-flow, a counter-flow box and instructions are provided. When it is used as a basement model, a drop duct and instructions are provided. The Series C and D Counter-Flow Boxes are interchangeable.

Before beginning installation, read these instructions carefully.

When making a Counter-Flow or Basement installation, also read the separate instructions furnished with the additional equipment required.

Install the furnace in accordance with the requirements of the local utility or authority having jurisdiction.

The installer is referred to the American Standard "Installation of Gas Appliances and Gas Piping," ASA Z21.30-1964, as a sound and practical guide to be followed when making the installation.

INSPECTION

Check the power supply available to be sure it agrees with the information on the wiring diagram and the blower motor in the furnace.

Check the gas specification on the A.G.A. rating plate to be sure that the type of gas for which the unit is equipped is the same as the gas supply available.

Leave these instructions on or near the furnace.

FILE
COPY
DO NOT
REMOVE



Model 393 Furnace

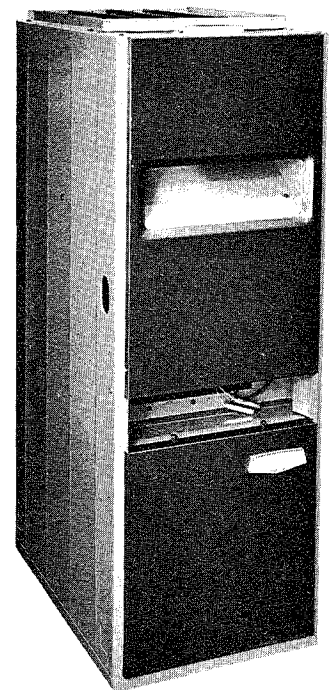

FILTERS

When the furnace air distribution system is used for cooling, it is recommended in certain instances that the throw-away filters be discarded and the permanent type, multi-velocity filters be substituted. The following table gives the air flows above which these high velocity filters should be used.

Size	Air Flow - cfm
80	800
100	1000
125	1240
150	1490
175	1800
200	1800

Permanent filters are not required on Size 50.

UPFLOW FURNACE

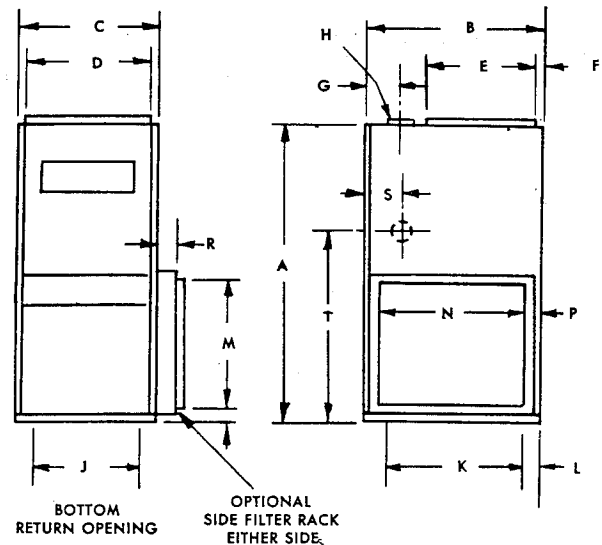

Model No.	A	B	C	D	E	F	G	H	J	K	L	M	N	P	R	S	T
50-393	46	26	16 $\frac{1}{4}$	14 $\frac{5}{8}$	20	$\frac{1}{2}$	2 $\frac{3}{4}$	4"	12 $\frac{1}{4}$	22 $\frac{1}{4}$	1 $\frac{1}{2}$	12	23	1 $\frac{1}{4}$	2	2 $\frac{3}{4}$	27 $\frac{1}{4}$
80-393	46	26	16 $\frac{1}{4}$	14 $\frac{5}{8}$	20	$\frac{1}{2}$	2 $\frac{3}{4}$	4"	12 $\frac{1}{4}$	22 $\frac{1}{4}$	1 $\frac{1}{2}$	12	23	1 $\frac{1}{4}$	2	2 $\frac{3}{4}$	27 $\frac{1}{4}$
100-393	46	26	18 $\frac{1}{4}$	16 $\frac{5}{8}$	20	$\frac{1}{2}$	3	5"	14 $\frac{1}{4}$	22 $\frac{1}{4}$	1 $\frac{1}{2}$	14	23	1 $\frac{1}{4}$	2	2 $\frac{3}{4}$	27 $\frac{1}{4}$
125-393	46	26	20 $\frac{1}{4}$	18 $\frac{5}{8}$	20	$\frac{1}{2}$	3	5"	18 $\frac{1}{4}$	22 $\frac{1}{4}$	1 $\frac{1}{2}$	18	23	1 $\frac{1}{4}$	2	2 $\frac{3}{4}$	27 $\frac{1}{4}$
150-393	51	28 $\frac{3}{4}$	28 $\frac{1}{4}$	26 $\frac{5}{8}$	17 $\frac{3}{4}$	2 $\frac{1}{2}$	5 $\frac{3}{8}$	6"	25 $\frac{1}{4}$	23 $\frac{1}{4}$	2 $\frac{5}{8}$	23	24	2 $\frac{1}{8}$	8 $\frac{1}{2}$	4	30 $\frac{1}{4}$
175-393	51	28 $\frac{3}{4}$	36 $\frac{1}{4}$	34 $\frac{5}{8}$	17 $\frac{3}{4}$	2 $\frac{1}{2}$	4 $\frac{3}{4}$	(2) 5"	33 $\frac{1}{4}$	23 $\frac{1}{4}$	2 $\frac{5}{8}$	23	24	2 $\frac{1}{8}$	8 $\frac{1}{2}$	4	30 $\frac{1}{4}$
200-393	51	28 $\frac{3}{4}$	36 $\frac{1}{4}$	34 $\frac{5}{8}$	17 $\frac{3}{4}$	2 $\frac{1}{2}$	4 $\frac{3}{4}$	(2) 5"	33 $\frac{1}{4}$	23 $\frac{1}{4}$	2 $\frac{5}{8}$	23	24	2 $\frac{1}{8}$	8 $\frac{1}{2}$	4	30 $\frac{1}{4}$
250-393	Sizes 250 thru 400 are multiples of sizes 125, 150, 175 and 200 respectively. Refer to the dimensions of smaller sizes to obtain overall dimensions for the larger sizes. Provide clearance dimension between units for gas service and casing expansion. Refer to installation instructions for clearance.																
300-393																	
350-393																	
400-393																	

MODEL NO.	A.G.A. RATINGS BTU/HR*		GAS CONNECTION SIZES			BOTTOM FILTER SIZES	SIDE FILTER SIZES	APPROX. SHIPPING WEIGHT
	INPUT	BONNET CAPACITY	NAT.	MFD.	Prop.			
50-393	50,000	40,000	$\frac{1}{2}$	$\frac{1}{2}$	$\frac{1}{2}$	14 x 25 x 1	14 x 25 x 1	135
*80-393	*80,000	64,000	$\frac{1}{2}$	$\frac{1}{2}$	$\frac{1}{2}$	14 x 25 x 1	14 x 25 x 1	155
100-393	100,000	80,000	$\frac{1}{2}$	$\frac{1}{2}$	$\frac{1}{2}$	16 x 25 x 1	16 x 25 x 1	178
125-393	125,000	100,000	$\frac{1}{2}$	$\frac{3}{4}$	$\frac{1}{2}$	20 x 25 x 1	20 x 25 x 1	200
150-393	150,000	120,000	$\frac{3}{4}$	$\frac{3}{4}$	$\frac{3}{4}$	(2) 14 x 25 x 1	(2) 16 x 25 x 1	275
175-393	175,000	140,000	$\frac{3}{4}$	$\frac{3}{4}$	$\frac{3}{4}$	(1) 16 x 25 x 1 (1) 20 x 25 x 1	(2) 16 x 25 x 1	355
200-393	200,000	160,000	$\frac{3}{4}$	$\frac{3}{4}$	$\frac{3}{4}$	(1) 16 x 25 x 1 (1) 20 x 25 x 1	(2) 16 x 25 x 1	355
250-393	250,000	200,000	(2) $\frac{1}{2}$	(2) $\frac{3}{4}$	(2) $\frac{1}{2}$	(2) 20 x 25 x 1	(2) 20 x 25 x 1	400
300-393	300,000	240,000	(2) $\frac{3}{4}$	(2) $\frac{3}{4}$	(2) $\frac{3}{4}$	(4) 14 x 25 x 1	(4) 16 x 25 x 1	550
350-393	350,000	280,000	(2) $\frac{3}{4}$	(2) $\frac{3}{4}$	(2) $\frac{3}{4}$	(2) 16 x 25 x 1 (2) 20 x 25 x 1	(4) 16 x 25 x 1	710
400-393	400,000	320,000	(2) $\frac{3}{4}$	(2) $\frac{3}{4}$	(2) $\frac{3}{4}$	(2) 16 x 25 x 1 (2) 20 x 25 x 1	(4) 16 x 25 x 1	710

The 250, 300, 350 & 400 sizes are multiples of the 125, 150, 175 & 200 respectively.
*For LP Gas, Model Designation 80-V-393, A.G.A. Input 75,000, Bonnet Capacity 60,000.

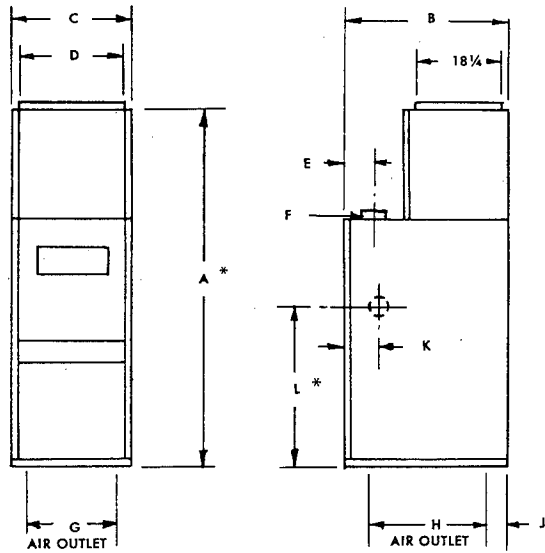

COUNTERFLOW FURNACE

MODEL NO.	A.G.A. RATINGS BTU/HR		* A	B	C	D	E	F	G	H	J	K	* L	GAS CONNECTION SIZES			FILTERS	APPROX. SHIPPING WEIGHT (LB.)
	INPUT	BONNET CAPACITY												NAT.	MFD.	Prop.		
**80-393	80,000	64,000	75	26	16 1/4	14 3/4	2 3/4	4"	12 1/4	22 1/4	1 1/2	2 3/4	27 1/4	1/2	1/2	1/2	16 x 20 x 1	185
100-393	100,000	80,000	75	26	18 1/4	16 3/4	3	5"	14 1/4	22 1/4	1 1/2	2 3/4	27 1/4	1/2	1/2	1/2	Two 10 x 20 x 1	210
125-393	125,000	100,000	75	26	20 1/4	18 3/4	3	5"	18 1/4	22 1/4	1 1/2	2 3/4	27 1/4	1/2	3/4	1/2	Two 14 x 20 x 1	235
150-393	150,000	120,000	80	28 3/4	28	26 3/4	5 3/8	6"	25 1/4	23 1/4	2 5/8	4	30 1/4	3/4	3/4	3/4	Two 16 x 20 x 1	325

* Add 1 1/4" when installed with base on combustible floor.

** For LP Gas, Model Designation 80-V-393, A.G.A. Input 75,000, Bonnet Capacity 60,000.

BASEMENT FURNACE

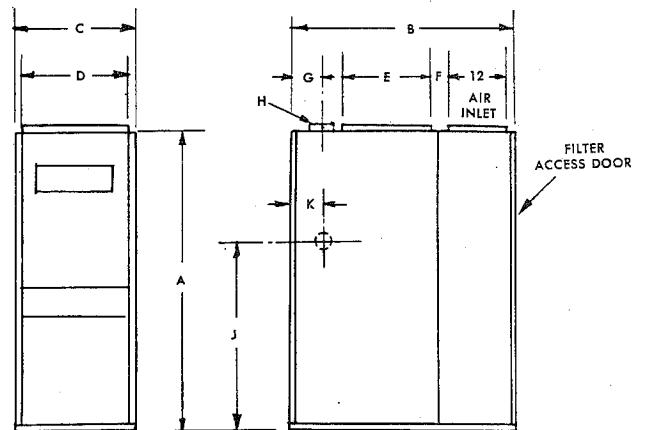

MODEL NO.	A.G.A. RATINGS BTU/HR		A	B	C	D	E	F	G	H	J	K	GAS CONNECTION SIZES			FILTERS	APPROX. SHIPPING WEIGHT (LB.)
	INPUT	BONNET CAPACITY											NAT.	MFD.	Prop.		
*80-393	80,000	64,000	46	40 1/2	16 1/4	14 3/8	20	2 1/2	2 3/4	4"	27 1/4	2 3/4	1/2	1/2	1/2	14 x 25 x 1	192
100-393	100,000	80,000	46	40 1/2	18 1/4	16 3/8	20	2 1/2	3	5"	27 1/4	2 3/4	1/2	1/2	1/2	16 x 25 x 1	213
125-393	125,000	100,000	46	40 1/2	20 1/4	18 3/8	20	2 1/2	3	5"	27 1/4	2 3/4	1/2	3/4	1/2	20 x 25 x 1	238
150-393	150,000	120,000	51	43 1/4	28 1/4	26 3/8	17 3/4	4 1/2	5 3/8	6"	30 1/4	4	3/4	3/4	3/4	Two 16 x 25 x 1	343
175-393	175,000	140,000	51	43 1/4	36 1/4	34 3/8	17 3/4	4 1/2	4 3/4	2-5"	30 1/4	4	3/4	3/4	3/4	Two 16 x 25 x 1	428
200-393	200,000	160,000	51	43 1/4	36 1/4	34 3/8	17 3/4	4 1/2	4 3/4	2-5"	30 1/4	4	3/4	3/4	3/4	Two 16 x 25 x 1	428
250-393	250,000	200,000	Sizes 250 through 400 are multiples of sizes 125, 150, 175, and 200 respectively. Refer to the dimensions of the smaller sizes to obtain overall dimensions for the larger sizes. Provide clearance dimensions between units for gas service and casing expansion. Refer to installation instructions for minimum clearances.														
300-393	300,000	240,000															
350-393	350,000	280,000															
400-393	400,000	320,000															

Ratings are approved for altitudes to 2,000 feet for all gases. Ratings for altitudes over 2,000 feet are 4% less for each 1,000 feet above sea level. Return air compartment shipped separately, knocked down.

* For LP Gas, Model Designation 80-V-393, A.G.A. Input 75,000 Bonnet Capacity 60,000.

GAS CONTROL OPTIONS

Components	Gas and Control Type		
	City Gas		LP Gas
	D4	D5	D2
Bryant Automatic Pilot	x	—	—
Bryant Gas Control Valve	x	x	x
Gas Pressure Regulator *	x	x	—
Transformer	x	x	x
Pilot Gas Filter **	x	x	—
100% Shut Off			
T. C. Pilot	—	x	x
Pilot Relay	—	x	—
Inline 100% Shut Off Valve	—	—	x

* On the sizes 50, 80, 100 & 125 for natural gas only, the regulator is part of a combination regulator, main gas shut-off and pilot shut-off.

** Mfd. gas only.

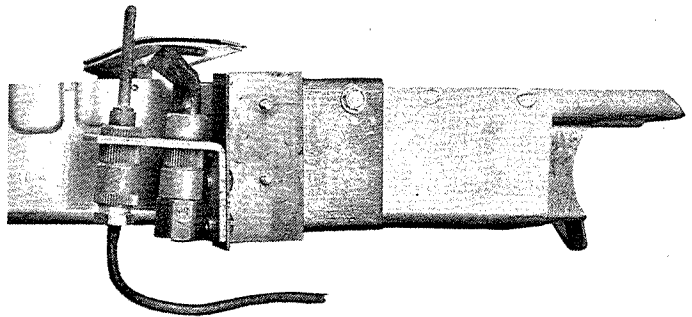

Figure 2 – Thermocouple Pilot
D2 & D5 Controls

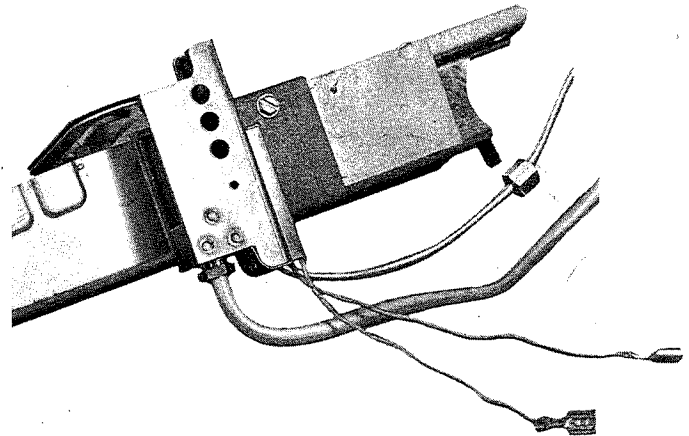

Figure 3 – Bryant 732 Pilot

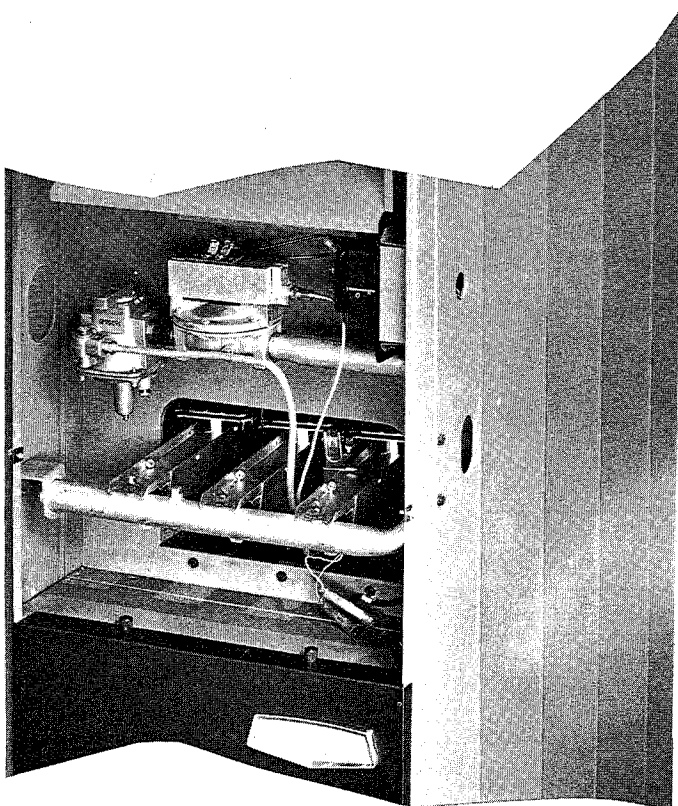

Figure 1 – D2 Controls
641 Valve - 732 Pilot

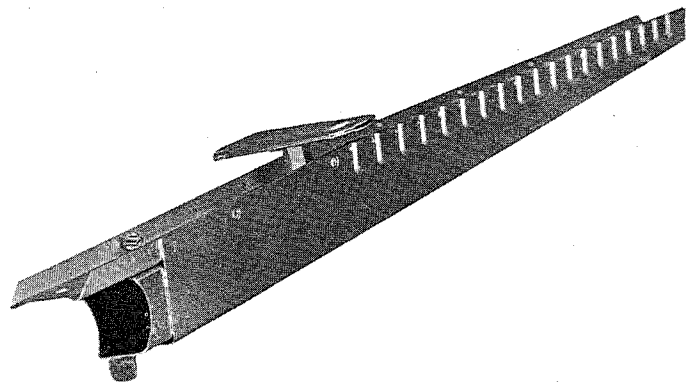

Figure 4 – Slotted Port Burner

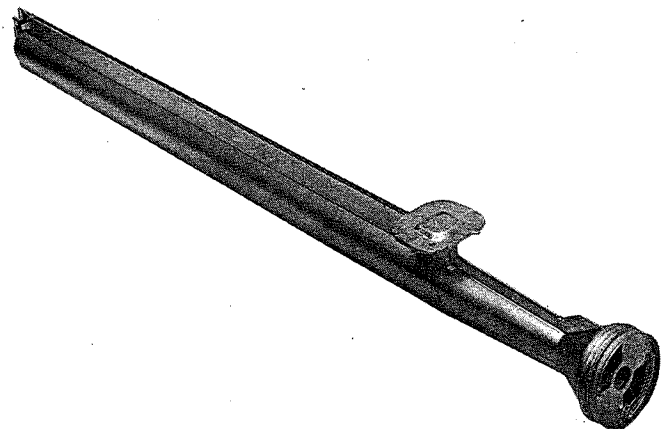

Figure 4a – Controlled Flame Burner

LOCATING THE UNIT

1. This gas furnace is approved for use on combustible floors except when installed as a counter-flow furnace. When installed as a counter-flow furnace on a combustible floor it must be installed on an approved base.

2. The furnace is A.G.A. approved for the following clearances from combustible construction in a closet or alcove installation.

Sides	0" (1")*
Back	0" (1")*
† Top of plenum	3" (0")*
Vent connector	6" (6")*
Front	6" (6")*

* Figures shown in parentheses are approved clearances when the furnace is installed as a counter-flow furnace.

† Refer to ASA Z21.30-1964 for clearances in open area installations.

3. Locate the furnace as close to the chimney as possible. The furnace should also be located as centrally as possible to the distribution system.

4. Provide ample space for servicing and cleaning. Consult your local approval agency for any special clearance requirements.

5. The furnace should be level. Use shims as required, if the floor or foundation is not completely level.

6. Advise owner to leave all air passageways to the furnace free of obstruction in order that there will be no interference with combustion and ventilating air.

7. The furnace is designed for use with summer air conditioning. Therefore consideration should be given to leaving ample space for a later installation of air conditioning equipment, if the air conditioning equipment is not being installed as part of the original furnace installation.

Bryant manufactures a coil box for upflow furnaces. If air conditioning will be added at a later date, the coil box, if installed on the original installation, will save time and money later. A coil box is not needed for counter-flow furnaces.

This gas furnace is not approved for use with air conditioning units mounted upstream from the furnace heat exchanger. The cooling coil should either be downstream of the furnace heat exchanger or the flow of cooling air should be by-passed around the heat exchanger. If this parallel arrangement is used, the dampers or other means used to control the flow of air must be adequate to prevent chilled air from entering the furnace. If these dampers are manually operated, they must be equipped with means to prevent operation of either unit unless the damper is in the full heat or full cool position.

8. In general, when the furnace is installed in a large open space, there will be enough air for combustion and ventilation. However, when the unit is installed in buildings of unusually air-tight construction, or when the furnace is located in very restricted spaces such as closets or utility rooms, special provisions must be made for combustion, ventilating, and draft hood dilution air.

When the unit is installed in a confined space, provide the confined space with two permanent openings, one near the top of the enclosure and one near the bottom. These openings must freely communicate with interior areas that have adequate infiltration air from the outside. Each opening must have a free area of not less than one square inch for each 1000 Btu/hr of rated input of all appliances located within the enclosure.

If it is not practicable to connect the two openings to interior space, or if the interior space has insufficient infiltration air, then it is necessary to connect the openings to the outside. If air openings are directly to outdoors, the minimum free area should be one square inch per 3000 Btu/hr of input rating or in accordance with Z21.30-1964 or latest edition, "American Standards for Installation of Gas Appliances and Gas Piping."

It is strongly recommended that the installer consult the "American Standards Installation of Gas Appliances and Gas Piping," ASA Z21.30-1964.

9. In restricted spaces it is very important that the return air ducts be sealed firmly into the furnace so that the return air will be kept separate from the combustion and ventilating air.

GAS PIPING

The gas supply line should be a separate line direct from the meter to the furnace. Check local utility for recommendations concerning existing lines. Choose a supply pipe size large enough to keep the pressure loss as low as practicable. The supply pipe should never be smaller than the inlet to the gas valve. For pipe capacities at 0.3 inches w.c. pressure drop, see Iron Pipe Capacity table below.

Observe local codes for all gas pipe installation. The following are pertinent recommendations:

1. Avoid low spots in long runs of pipe. These low spots may trap water in the supply line. It is best to slope all pipe 1/4 inch in 15 feet to prevent traps. All horizontal runs should slope to risers. Risers should be used to connect to the furnace and to the meter.
2. Install a drip leg in the riser leading to the furnace. This drip leg will serve as a trap for dirt or condensate.

This drip leg can be installed by connecting a TEE to the riser leading to the furnace, so that the straight-through section of the TEE is vertical. Then connect a capped nipple to this TEE. The capped nipple should extend below the level of the gas controls, with the cap resting on the floor.

3. Install the main manual gas shut-off valve in the supply line five feet above the floor. Install the valve (supplied) so that the pilot manual cock is on the inlet side of the valve. (See Figure 5.)

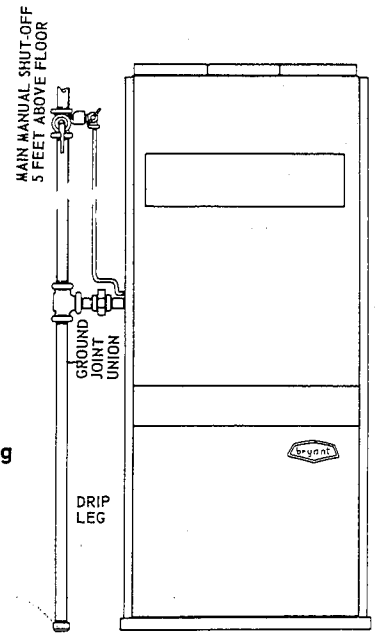

Figure 5 - Gas Piping

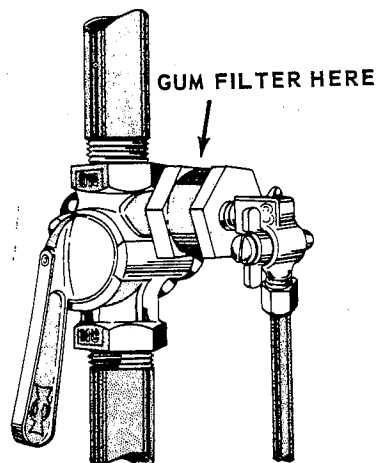

Figure 6

IRON PIPE CAPACITY (See Notes 1 & 2)

Length of Pipe in Feet	Pipe Capacity in Cubic Feet Per Hour for Diameters Shown				Multiplier to Use for Different Specific Gravity	
	1/2"	3/4"	1"	1-1/4"	Specific Gravity	Multiplier
15	76	172	345	750	.35	1.31
30	52	120	241	535	.40	1.23
45	43	99	199	435	.45	1.16
60	38	86	173	380	.50	1.10
75		77	155	345	.55	1.04
90		70	141	310	.60	1.00
105		65	131	285	.65	.962
120			120	270	.70	.926
150			109	242		
180			100	225		

1. All values shown are based on a pressure drop of 0.3" w.c. and using gas with a specific gravity value of 0.60. Consult local utility for local variations.
2. To convert to capacities for gas of different specific gravity, multiply the capacity values by the multipliers shown at the extreme right on table.

Sizes 50, 80, 100 & 125 using natural gas are equipped with a factory-installed combination pressure regulator and main shut off - pilot supply shut off valve. This control is inside the furnace cabinet. A separate manual shut-off valve is not supplied with these furnaces. Consult local codes regarding the need for placing a separate shut-off valve outside the furnace cabinet as shown in Figure 5.

Where a gum filter is required by local regulations, place filter between manual gas cock and pilot cock. See Figure 6.

Place a ground joint union between the gas control manifold and the manual gas shut-off valve.

4. Support all piping with appropriate straps, hangers, etc. This will maintain proper slope of the lines as installed and will remove unnecessary strain on the furnace and its controls. It will also prevent the piping from being moved accidentally from its installed position.

5. Joint compounds - (pipe dope) should be applied sparingly and only to the male threads of the joints. Consult local supplier for type of compound to be used with LP gas.

6. After all connections have been made, purge the lines and check for leakage. Never purge a line into a combustion chamber. Never use matches, candles, flame, or other sources of ignition for the purpose of checking leakage.

VENTING THE FURNACE

Consult local codes. Unless the local codes direct otherwise the furnace may be vented to a permanent chimney, or to a listed Type B or Type C gas vent.

This Bryant gas-fired furnace has a built in draft diverter. Therefore, it remains only to connect the furnace vent collar to the chimney or gas vent to be used. The following recommendations are made:

1. Select a flue connection material that is satisfactory for the installation, and that meets the requirements of the local codes.

2. The flue connection pipe must be the same size as the outlet collar on the furnace. No reduction in this size is permissible in the pipe run.

3. Run pipe as directly as possible with a minimum number of turns. The maximum length of horizontal run should not exceed 75 percent of the height of the chimney.

4. Maintain a minimum of 1/4 inch per linear foot upward slope from the furnace to the chimney on all horizontal runs.

5. Rigidly support the flue pipe with hangers and straps to insure that there will be no movement after installation.

6. Extend the flue connection pipe through the chimney wall flush with the inner face of the chimney liner. Never connect into a chimney serving an open fireplace, unless the fireplace opening is sealed off.

7. The chimney or gas vent should extend high enough above the roof or neighboring obstruction so that wind from any direction will not create a positive pressure in the vicinity of the outlet of the chimney or gas vent. The installer is referred to Part V of American Standard "Installation of Gas Appliances and Gas Piping, ASA Z21.30-1964 for detailed information on chimney and gas vent use. In general the chimney or gas vent should extend 3 feet higher than the point of emergence through the roof, and at least 2 feet higher than any object within a radius of 15 feet.

8. If more than one appliance is vented into the same chimney, the cross sectional area of the chimney must be as large as the largest flue pipe being connected, plus 50 percent of the cross sectional areas of the additional flue pipes being connected.

9. If more than one appliance is manifolded into the same flue connecting pipe, the cross sectional area of this manifold pipe must be as large as the sum of the cross sectional areas of the pipes connecting into it.

BLOWERS

Direct Drive:

Listed below are the color codes for the different motor speed taps:

High Speed – Black

Medium Speed – Blue

Medium-low Speed – Yellow

Low Speed – Red

Wiring Diagram, Figure 10 shows these furnaces as wired at the factory. Remove the transformer (two screws) from the junction box and expose the terminal block. Check the fan control lead to see if it is connected to the motor speed tap that will give the blower speed needed for the installation. If the fan control lead is not connected to the proper motor speed tap, or if you wish to change to another speed, simply switch the lead to the motor speed tap that you want connected. The lead is equipped with a spade connector.

Important:

If there are variations in voltage at the motor, there will be significant variations in the air delivery and temperature rise values. If the supplied voltage is less than 115 volts the blower will run slower and the temperature rise will be greater. On the other hand, if the voltage is greater than 115 volts the blower will run faster and the temperature rise values will be lower. If there is doubt about the value and fluctuation of voltage consult local electric utility. The Number 4 tap should be used on installations where the voltage is 125 volts or higher.

Belt Drive:

The motors supplied with the belt drive have an adjustable motor pulley. The air delivery rate is controlled by the position of this adjustable motor pulley. When the pulley is in the fully open position, the air delivery rate is at a minimum, and consequently the temperature rise across the furnace is at the maximum.

When the pulley is in the fully closed position, the air delivery rate is maximum and consequently the temperature rise across the furnace is at a minimum. In order to change the opening on the pulley simply loosen the set screw with an Allen wrench. Screw the pulley clockwise to close, and counter-clockwise open. Once positioned, tighten the set screw on the flat of the motor shaft.

Larger Motors:

For some installations the installer may wish to substitute a larger motor than the one supplied the furnace. A separate mounting hole is provided in each end plate of the blower cage to be used when motors larger than 1/3 HP are installed. This is an extruded hole requiring self-tapping bolts. Figure 7 is a photo of a 1/2 HP motor mounted in place of a smaller motor. Note that the lower mounting hole is used. When ordering a 1/2 HP motor for installation be sure that the frame is a size 56. When ordering still larger motors, be sure that the frame size is compatible with space available in the blower compartment.

When the lower mounting holes are used it will, of course, be necessary to use a longer belt than the one supplied with the smaller motors.

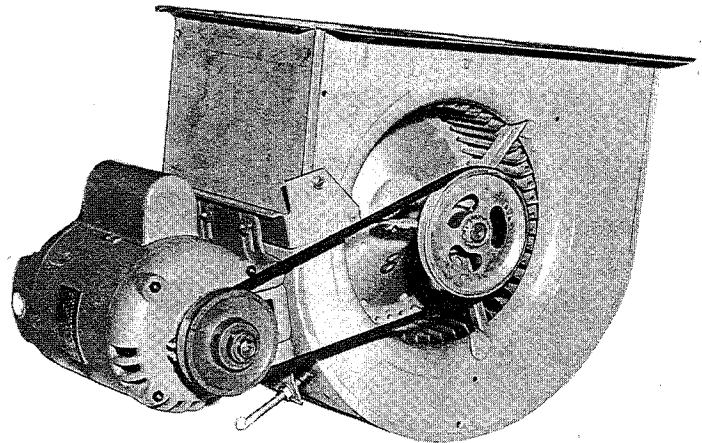

Figure 7

**TABLE I
DIRECT DRIVE BLOWERS – HEATING ONLY**

Furnace Size	Motor H.P.	No. of Speed Taps	Ext. S. P. Inches Water	Temp. Rise Degrees F.	Factory Setting	† CFM at 85° F Temp. Rise
50	1/6	4	0.12	50-70	3	†† 615
80	1/6	4	0.12	75-95	3	695
100	1/5	4	0.15	75-95	1	870
125	1/4	2	0.20	75-95	1	1090

† Values shown are for 115 volt power supply

†† Temp rise is 60° F

**TABLE II
HEATING AND COOLING BLOWERS**

Furnace Size	Motor H.P.	No. of Speed Taps	Temp. Rise Degrees F. Motor Speed Taps				Ext. S.P. In. w.c.	Cooling Air Flow-CFM § at Motor Speeds Shown			
			Hi	Med	Med-Lo	Lo		Hi	Med	Med-Lo	Lo
50	1/6	4	*	*	60-70	*	0.32	710	610	485	dna
80	1/6	4	*	80-90	95-105	*	0.30	810	660	510	dna
							0.35	785	645	500	dna
							0.40	760	625	490	dna
80	1/3	4	*	*	*	80-90	0.30	1185	980	865	dna
							0.35	1160	965	850	dna
							0.40	1130	940	830	dna
							0.50	1080	895	815	dna
100	1/6	4	80-90	90-100	*	*	0.30	830	675	505	dna
							0.35	805	655	495	dna
							0.40	775	635	490	dna
100	1/3	4	*	70-75	75-85	*	0.30	1250	1030	900	dna
							0.35	1215	1015	890	dna
							0.40	1200	1000	870	dna
							0.50	1110	960	830	dna
125	1/3	4	*	80-90	90-100	*	0.30	1525	1060	925	dna
							0.35	1500	1045	910	dna
							0.40	1470	1030	900	dna
							0.50	1400	1010	860	dna

dna = does not apply * = speed tap not recommended for heating § Values shown are for 115 volt power supply

**TABLE III
BELT DRIVE BLOWERS**

Furnace Size	Motor H.P.	Heating			Heating and Cooling					
		Factory Setting	CFM @ 0.20	Temp. Rise	Motor H.P.	Factory Setting	CFM @ 0.20	Temp. Rise	Max. CFM @ 0.40	Approx. A/C Capacity
80	1/6	3 T.O.	570	97° F	1/3	4 T.O.	790	70° F	1080	30M
100	1/4	3 T.O.	730	95° F	1/3	4 T.O.	930	75° F	1270	36M
125	1/4	4½ T.O.	950	92° F	1/3	4½ T.O.	950	92° F	1080	36M
					1/2	5 T.O.	1280	68° F	1800	48M
150	1/3	5 T.O.	1160	90° F	1/2	5 T.O.	1160	90° F	1840	48M
					3/4	5 T.O.	1600	65° F	2280	60M
175	1/3	5 T.O.	1475	83° F	1/2	5 T.O.	1500	81° F	2400	54M
					3/4	5 T.O.	1500	81° F	2400	66M
200	1/3	5 T.O.	1475	94° F	1/2	5 T.O.	1500	93° F	2400	54M
					3/4	5 T.O.	1500	93° F	2400	66M

ELECTRICAL CONNECTIONS

All electrical connections are to be made in accordance with the local codes governing such wiring.

A permanent, live, separately fused electric power supply, complete with manual switch, should be provided for the furnace.

The room thermostat should be located where it will be in the natural circulating path of room air. Avoid locations where the thermostat would be exposed to cold air infiltration, drafts from windows, doors, or other openings leading to the outside; or exposure to air currents from warm or cold air registers; or to exposure where the natural circulation of the air is cut off such as behind doors, above or below mantels, shelves, etc.

The thermostat should not be exposed to heat from nearby radiators, fireplaces, radios, televisions, lamps, or rays from the sun. Nor should the thermostat be mounted on a wall containing pipes or warm air ducts, or a flue or vent which could affect its operation and prevent it from properly controlling the room temperature. Any hole in the plaster or panel through which the wires pass from the thermostat should be adequately sealed with suitable material to prevent drafts from affecting the thermostat.

INSTALLING THE UNIT

Sizes 50, 80, 100 & 125 for natural gas are completely assembled at the factory. All other units are shipped fully assembled with the exception of the manual main shut-off valve, pilot feed tube, and pilot gas filter, which are shipped loose. The filter is supplied for manufactured gas units only.

The order to be followed in setting the unit in place and making all the necessary connections (gas, electric, venting, duct work, etc.) is left to the discretion of the installer. Recommendations listed on pages 5 to 7 of this instruction should be followed. When making the gas piping installation as described on page 6, assemble the pilot manual shut off valve in the threaded boss provided at the inlet side of the main manual gas shut-off valve. If the installation is for manufactured gas, install the gum filter between the two valves. Cut the pilot feed tube to the desired length and connect the pilot manual shut-off to the pilot.

For furnaces with D2 or D5 controls the pilot feed tube is connected to the pilot relay.

START-UP AND ADJUSTMENT

Check to be sure that all connections have been properly made, then proceed as follows:

Light the pilot using the procedure outlined on the Lighting Instruction Plate attached to the furnace. However, when lighting the pilot for the first time, perform the following additional steps:

1. If the supply line was not purged prior to connecting the furnace, it will be full of air. Since it would take a long time to vent this air through the small pilot port, it is recommended that the pilot supply line be disconnected at the pilot shut-off valve and the supply line be allowed to purge until the odor of gas is detected. **Never purge gas lines into the combustion chamber.** Immediately upon detection of gas odor, re-connect the pilot supply tube. Allow 5 minutes to elapse and light the pilot in accordance with the instructions on the front of the furnace.

2. The pilot flame should be soft blue in color.

- a. For city gas controls (D4) this flame should be of sufficient length to provide good impingement on the mono-metal element of the Bryant pilot. Flame should extend upward between the carry-over ports of the two adjacent burners.

- b. For LP gas controls (D2), the flame should surround the tip of the thermocouple element of the pilot and extend downward to include 3/8 inch to 1/2 inch of the thermocouple. The flame must never come in contact with any other part of the thermocouple or its lead wire. The flame lies under the carry-over ports of the burners and merges with the carry-over flames. D5 controls have the same pilot.

3. If the pilot flame does not have the appearance described above, it may be adjusted by means of the manual pilot shut-off valve.

- a. If the valve is equipped with an adjustable screw, turn the handle to the full-open position and remove the screw cap on the valve handle, thus exposing the adjustable screw. Turn adjusting screw until flame has the desired appearance. Replace screw cap.

- b. If the valve is not equipped with the adjusting screw, adjustment of the flame is effected by altering the position of the valve handle.

Light Main Burners using the procedure contained on the metal Lighting Instruction Plate attached to the front of the furnace.

Adjust Gas Rate. Set the room thermostat on call for heat and adjust the gas rate as follows:

1. **City Gases** – Measure gas input at the meter. The burners are equipped with fixed orifices, sized to produce the rated input shown on the rating plate. If measured and rated input are not approximately the same, the gas pressure regulator may be adjusted as follows:

a. To increase input: Turn gas pressure regulator adjusting screw 'clockwise'. (Adjusting screw is concealed under the regulator sealing cap).

b. To decrease input: Turn the adjusting screw 'counter-clockwise'. The manifold pressure should be set as follows:

Manufactured Gas – 3 inches w.c.

Natural Gas – 3 inches w.c.

Maximum pressure departure from recommended pressure should be plus or minus 0.3 inches w.c.

2. **LP Gas** – LP gas units are not equipped with gas pressure regulators. Burner orifices are sized to give the rated input at a manifold pressure of 11 inches w.c. Since meters are not normally used with LP gas, it will be necessary in most cases to check the manifold pressure and adjust the regulator at the supply tank to provide a pressure of 11 inches w.c.

3. If the input in item (1) or (2) above is too great or too little, install new orifices or re-drill the existing orifices (whichever is necessary) to obtain the rated input. Be sure the rated input is obtained without any appreciable change in manifold gas pressure.

Adjust Main Burner Flame – The main burner flame should be clear blue, almost transparent, with a well-defined inner cone. If there is insufficient primary air, the flame will be yellow-tipped. If there is too much primary air the flame will be well-defined, but with a tendency to dance or lift off the burner ports.

1. Allow furnace to operate 15 minutes.

2. Adjust each burner by closing the air shutter until a slight yellow tip appears on the flame; then open the air shutter just enough to clear the yellow from the flame.

CHECK CONTROLS

Bryant Diaphragm Gas Control Valve – if not already checked when lighting the main burner, check the proper operation of this valve by moving the room thermostat pointer above and below room temperature and observe that the main burners light on call for heat and go off when the pointer is moved below the room temperature setting. However, there will be approximately a 30 second delay on ignition and extinction.

Automatic Pilot – To check the pilot operation follow the instructions below:

1. Set the room thermostat on call for heat.

There is a delay before burners light.

2. After burners have lit, shut off the pilot gas valve.

3. The automatic pilot will break the electrical circuit to the gas valve and the burners will shut off.

Limit Control – This control functions to shut off the gas if the furnace becomes over-heated. The method of checking satisfactory operation is left to the discretion of the installer. Extreme caution should always be employed.

Blower Adjustment – It is important that the blower speed be adjusted before there is any attempt to adjust the fan control switch.

The blower speed is set at the factory. Under no circumstances should the temperature rise across the furnace be allowed to exceed 105 degrees F on all sizes except the size 50. On the size 50, the temperature rise must not be allowed to exceed 70 degrees F. After the desired air flow or temperature rise across the furnace has been obtained, the installation should be complete. However, it may be necessary to change the factory setting on the Fan Control Switch. This may be done as described under the discussion on controls.

CLEANING THE FURNACE

1. Disconnect gas tubing from pilot.
2. Disconnect electrical lead from pilot. (In case of 100% shut-off controls disconnect pilot thermocouple lead from pilot relay).
3. Remove front plate from draft diverter (4 sheet metal screws.)
4. Remove burners and pilot as follows.
 - a. Remove tinnerman clamp from burner holding stud.
 - b. Lift burner off holding stud, twist and pull forward.
 - c. Pilot is attached to one burner and is removed with that burner. It is not necessary to detach pilot before removing burner. See Figure 3 for photograph of burner; also pilot attached.
5. Remove metal angle strip holding flue baffles in place. See Figure 8.
6. Remove flue baffles. See Figure 9.
7. Use a flexible-handled steel cleaning brush to loosen scale and soot. Remove these scrapings from bottom of combustion chamber.
8. Re-assemble furnace by reversing the above procedure. Note: There is a slot in the back of the heat exchanger for the back tip of the burner to fit into. When properly placed, the burner will fit into this slot and will be level.

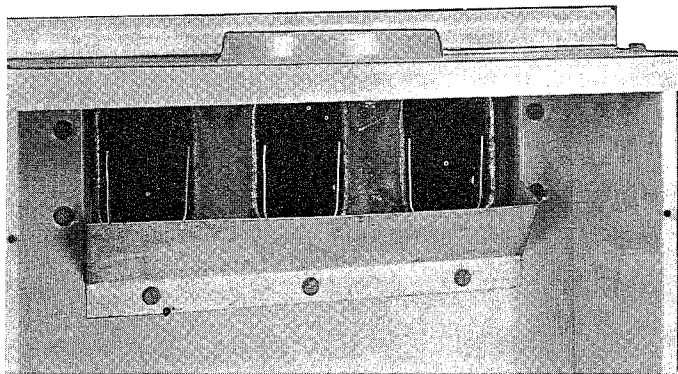

Figure 8 – Note metal angle strip held by 3 screws

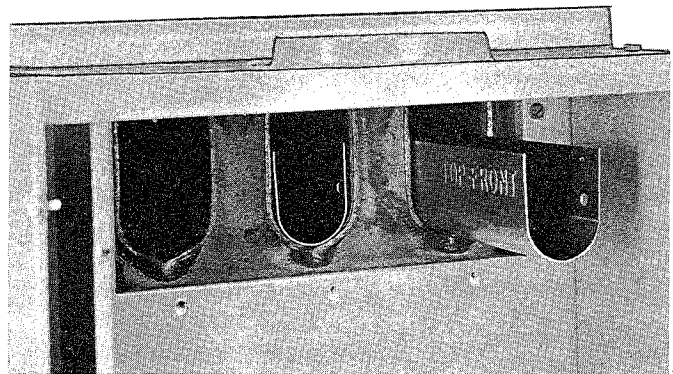

Figure 9 – Remove baffles

CARE AND MAINTENANCE

Care of Blowers. All motors on the belt drive blowers are provided with oil cups and should be oiled at least twice a year with a good grade of SAE 30 oil. The motors on the direct drive blowers are sealed units and do not require the addition of oil.

Blower bearings are semi-permanently lubricated. This lubrication is normally good for 3 to 5 years. When necessary to add lubricant, use Plastic E, obtainable from Bryant's Service Parts Department.

Filters. Filters should be examined frequently for clogging due to dirt. The disposable filters should be replaced when they become dirty. Permanent type of filters may be cleaned using clear water. Be sure to coat the filter with water soluble oil after cleaning.

Cleaning. The heat exchanger should be examined periodically to see if there has been an accumulation of rust, soot, etc. Clean as required.

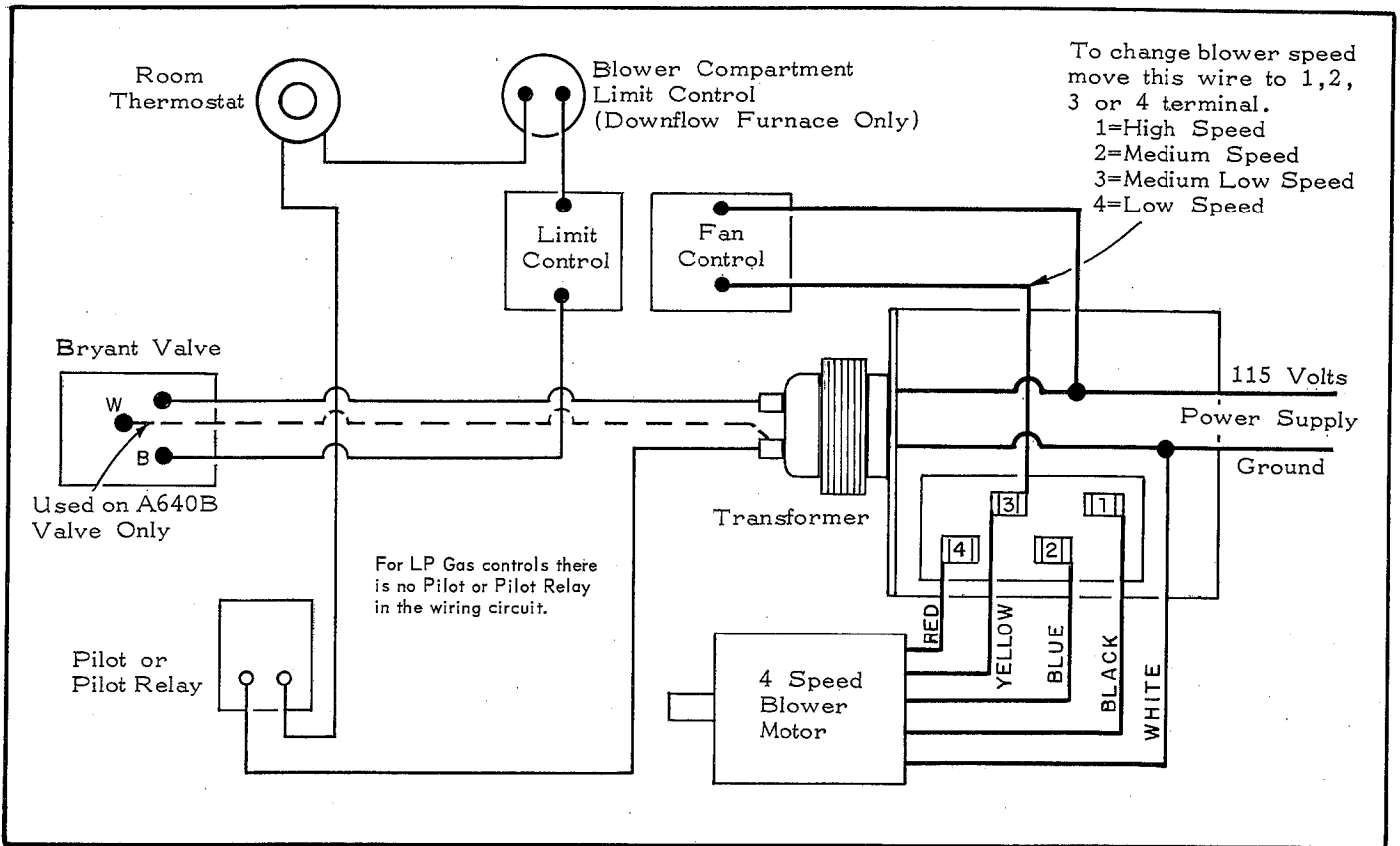

Figure 10 - Wiring for 4-Speed Direct Drive

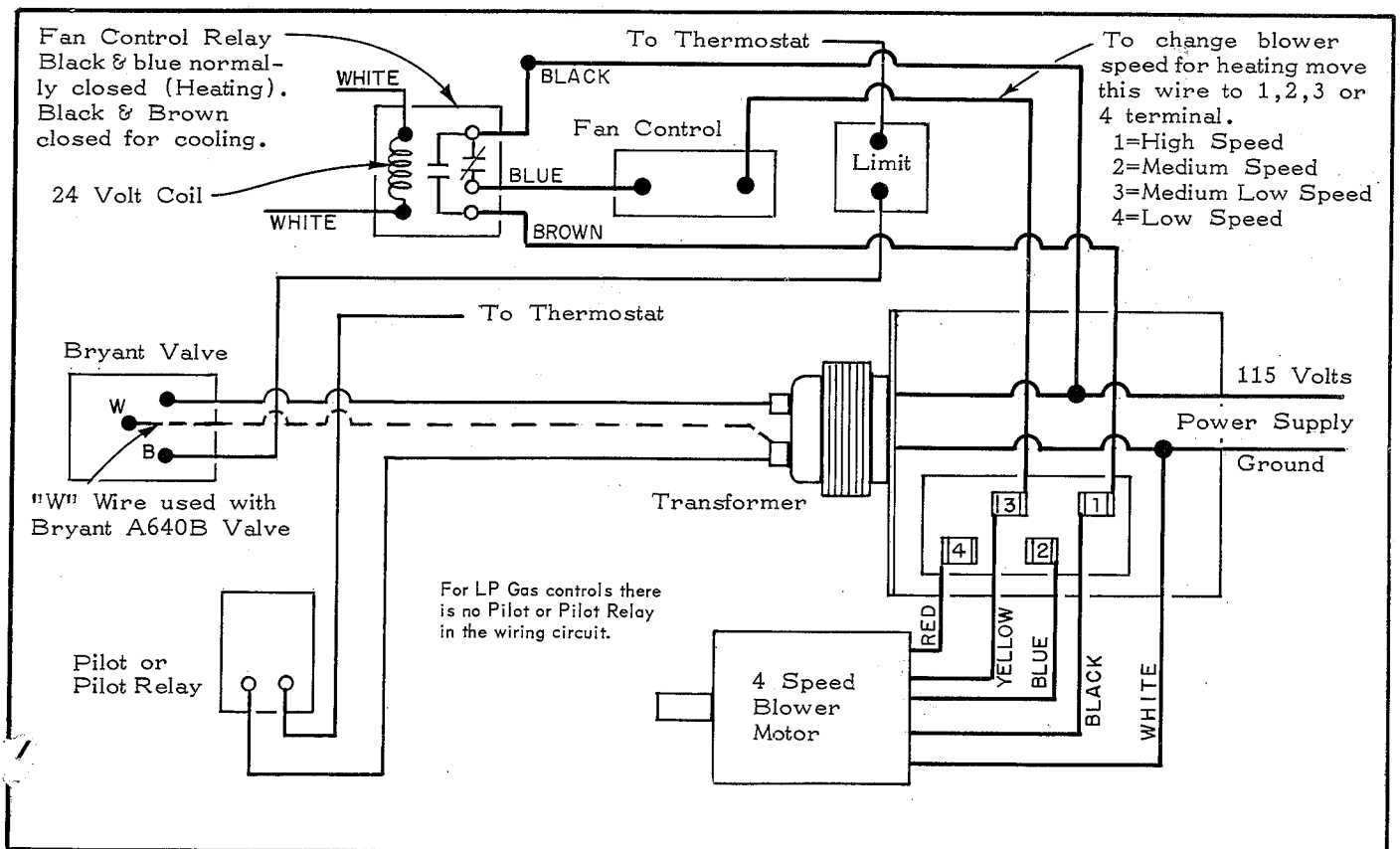

Figure 11 - Wiring for 4-Speed Direct Drive Using Relay

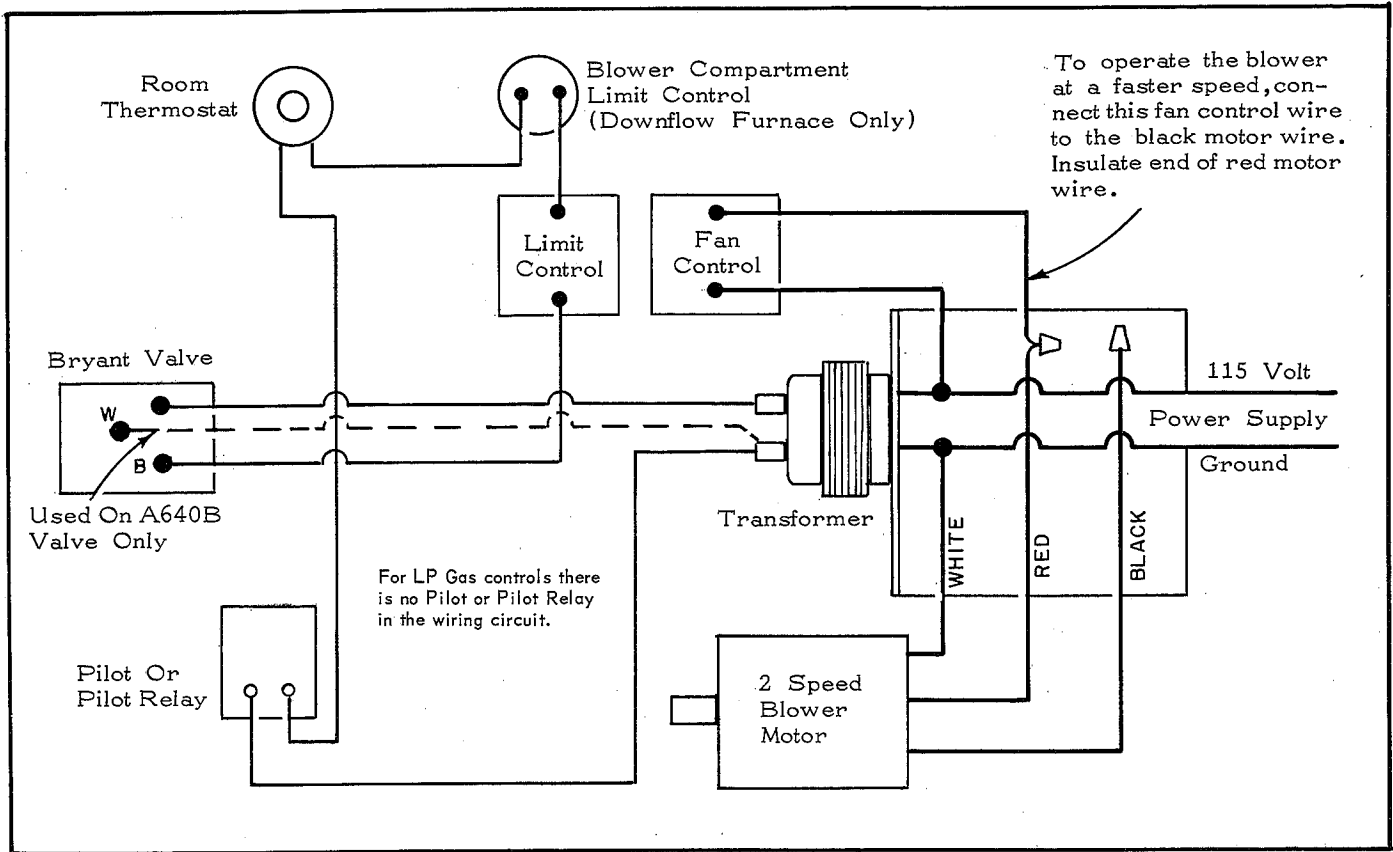

Figure 12 - Wiring for 2-Speed Direct Drive

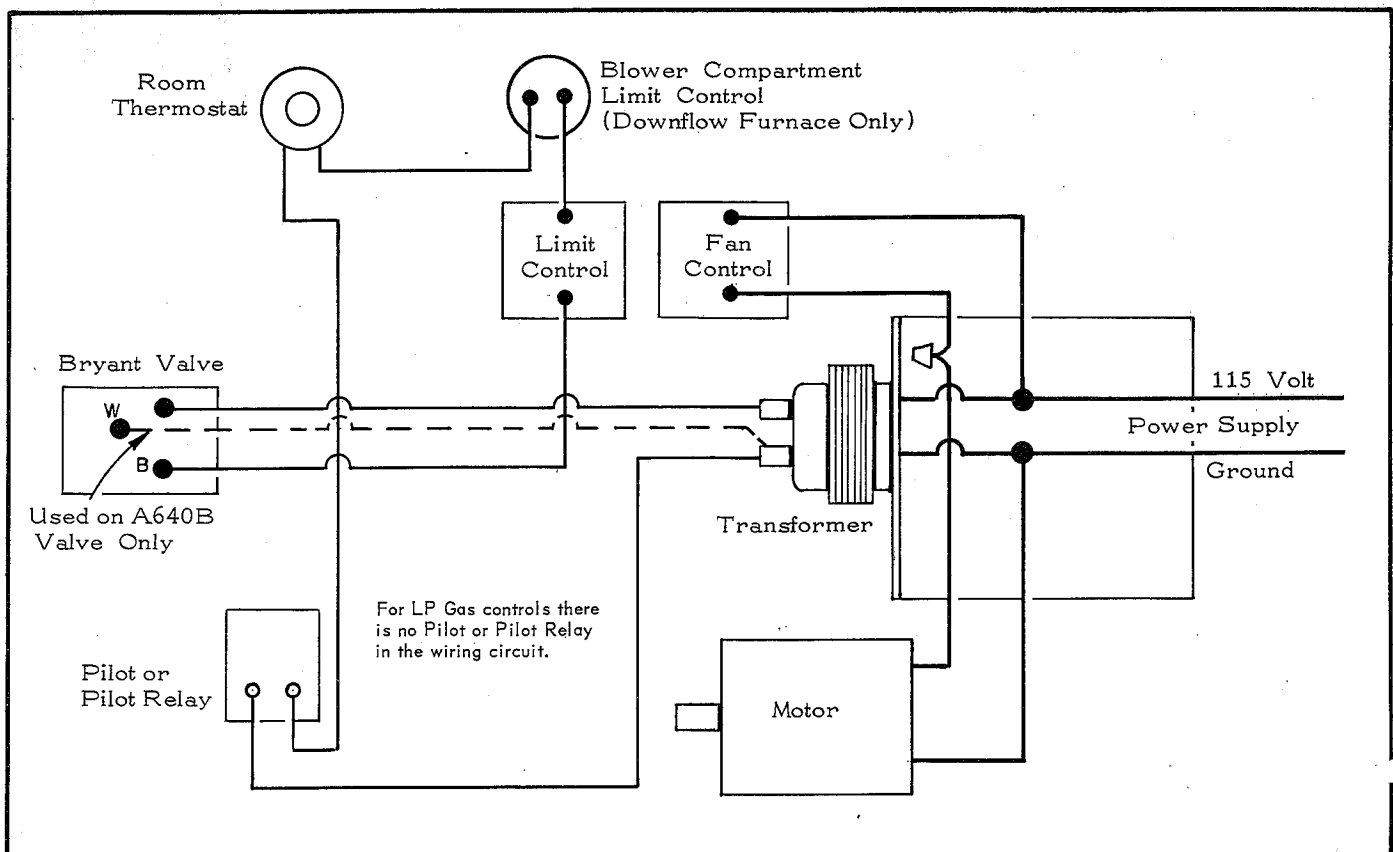

Figure 13 - Belt Drive Wiring

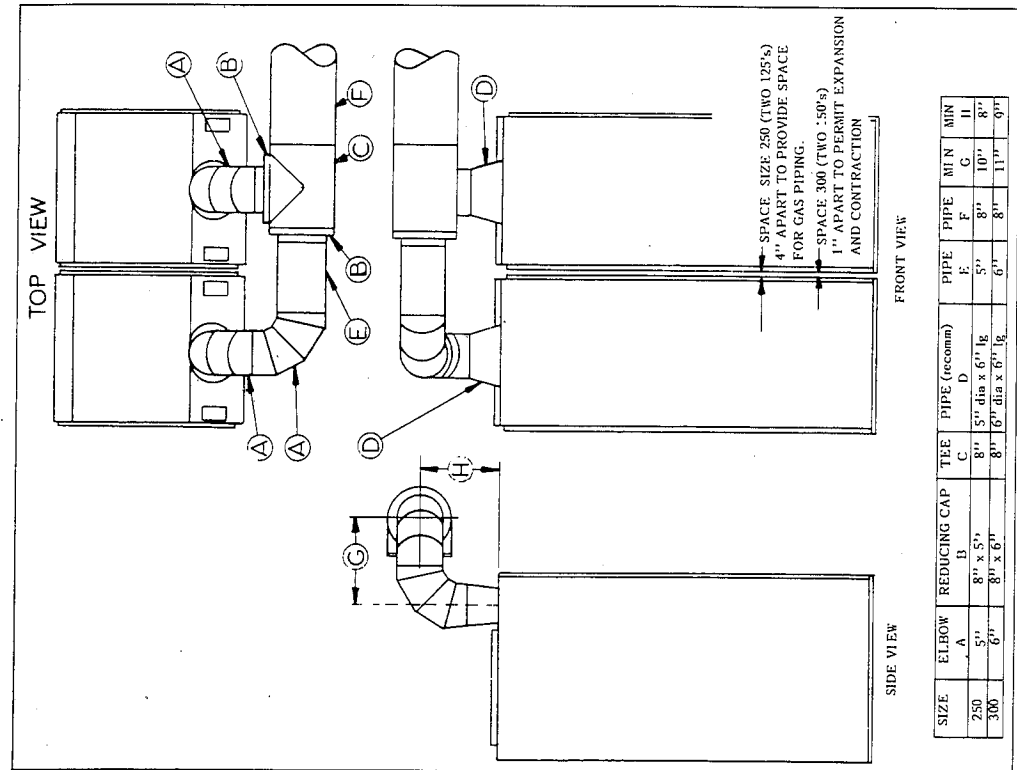
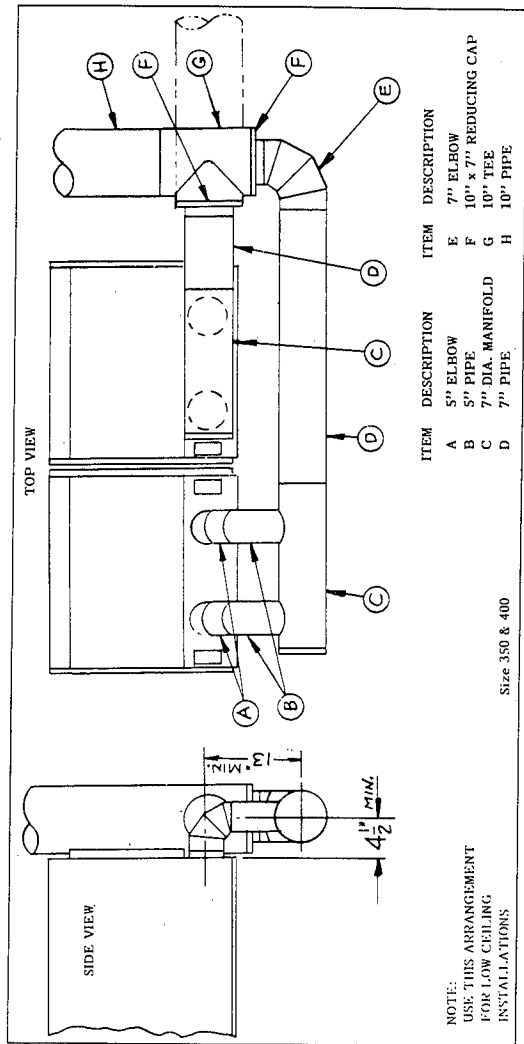
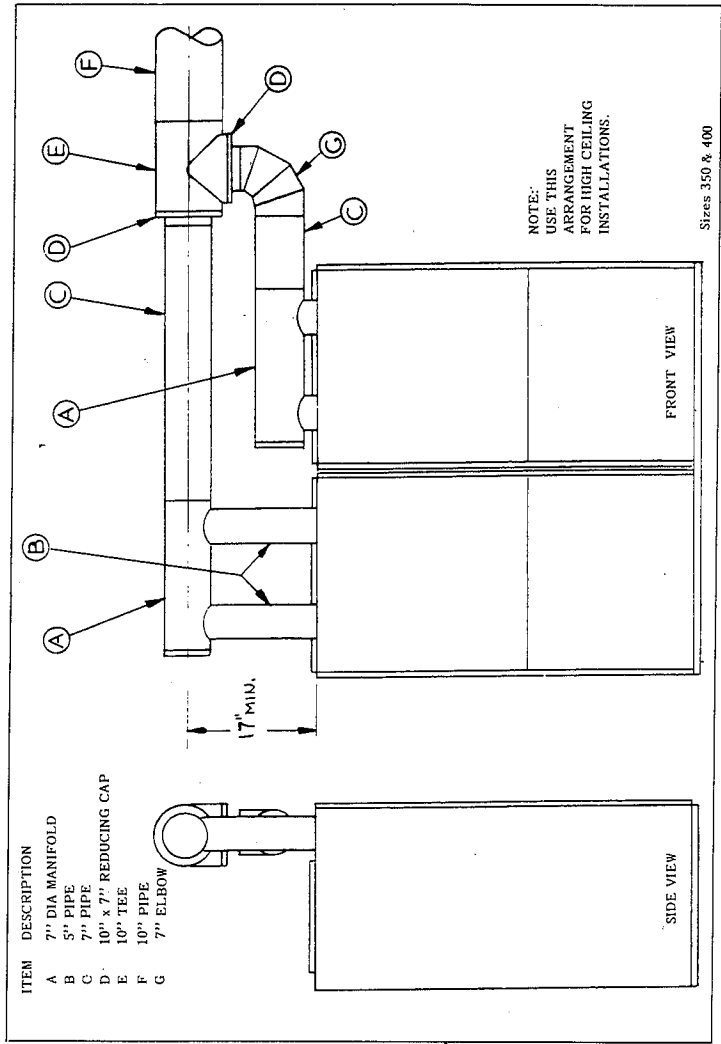

Figure 14 - Venting Arrangement for Multiple Units

Free Manuals Download Website

<http://myh66.com>

<http://usermanuals.us>

<http://www.somanuals.com>

<http://www.4manuals.cc>

<http://www.manual-lib.com>

<http://www.404manual.com>

<http://www.luxmanual.com>

<http://aubethermostatmanual.com>

Golf course search by state

<http://golfingnear.com>

Email search by domain

<http://emailbydomain.com>

Auto manuals search

<http://auto.somanuals.com>

TV manuals search

<http://tv.somanuals.com>