



Installation, Start-Up and Service Instructions

CONTENTS

	Page
GENERAL	2
SAFETY CONSIDERATIONS	2
INSTALLATION	3-25
Location	3
Step 1 — Inspect Shipment	3
Step 2 — Rig the Unit	3
• 30HK,HL UNITS	
• 30HW UNITS	
Step 3 — Place the Unit	3
• 30HK,HL UNITS	
• 30HW UNITS	
Step 4 — Check Compressor Mounting and Connections	3
Step 5 — Make Piping Connections	13
• 30HK,HWC,HWS CONDENSER DESCRIPTION	
• 30HL,HWA SYSTEM CONDENSER	
• 30HWB CONDENSER DESCRIPTION	
• 30HK,HWC,HWS CONDENSER(S)	
• 30HWB CONDENSER	
• 30HK,HWB,HWC,HWS UNITS	
• COOLER DESCRIPTION	
• COOLER PIPING	
Step 6 — Make Electrical Connections	19
• 30HK,HL UNITS	
• 30HW UNITS	
• ALL UNITS	
PRE-START-UP	25-27
Initial Check	25
Check Refrigerant Charge	26
• LIQUID CHARGING METHOD	
Check Oil Charge	27
• TO ADD OIL	
• TO REMOVE OIL	
START-UP AND OPERATION	27-30
Operation Checks	27
Operating Limitations	27
• HIGH COOLER LEAVING CHILLED WATER (FLUID) TEMPERATURES (LCWT)	
• LOW COOLER LCWT	
• MAIN POWER SUPPLY	
Check Refrigerant Feed Components	27
• THERMOSTATIC EXPANSION VALVE (TXV)	
• FILTER DRIER	
• MOISTURE-LIQUID INDICATOR	
• LIQUID LINE SERVICE VALVE	
• DISCHARGE LINE CHECK VALVE	
• HOT GAS BYPASS VALVE	
• LIQUID LINE SOLENOID VALVE (30HL ONLY)	
• PRESSURE RELIEF DEVICES	
Compressor and Unit Protective Devices	28
• CIRCUIT BREAKER	
• COMPRESSOR INTERNAL THERMAL PROTECTION	
• CRANKCASE HEATER	
• OIL PRESSURE SAFETY SWITCH (OPS)	
Check Unit Safeties	28
• CONTROL MODULE	
• HIGH-PRESSURE SWITCH	
• LOW-PRESSURE SWITCH	
• CHILLED FLUID TEMPERATURE CONTROLLER	
• FREEZE-UP PROTECTION	
• LOSS-OF-COOLER-FLOW PROTECTION	
• COMPRESSOR GROUND FAULT SENSOR	
UNIT OPERATION	30-32
Capacity Control and Operating Sequence	30
• 30HK,HL UNITS	
• 30HW UNITS	
SERVICE	32-35
Compressor Replacement	32
Circuit Breaker(s)	32
Brazed-Plate Cooler and Condenser Heat Exchanger Replacement	32
Brazed-Plate Cooler and Condenser Heat Exchanger Cleaning	32
Shell-and-Tube Condenser Cleaning	32
Thermistor	33
• THERMISTOR REPLACEMENT, 30HK,HL UNITS	
• THERMISTOR REPLACEMENT, 30HW UNITS	
SERVICING COOLER (30HK,HL ONLY)	36,37
Tube Plugging	36
• RETUBING	
Tightening Cooler Head Bolts	36
• GASKET PREPARATION	
• BOLT TORQUES	
TROUBLESHOOTING	37-39
Complete Unit Stoppage and Restart	37
• GENERAL POWER FAILURE	
• UNIT ON-OFF SWITCH IS OPEN	
• CONTACTS OF ANY AUXILIARY INTERLOCKS ARE OPEN	
• CHILLED FLUID PROOF-OF-FLOW SWITCH(ES) OPEN	
• OPEN LOW-PRESSURE SWITCH	
• TEMPERATURE CONTROLLER SHUTS UNIT DOWN ON OUT-OF-RANGE	
• OPEN HIGH-PRESSURE SWITCH(ES)	
• OPEN COMPRESSOR INTERNAL THERMAL PROTECTION	
• OPEN OIL PRESSURE SWITCH	
• OPEN CONTACTS ON COMPRESSOR GROUND-CURRENT SENSOR(S) (Accessory)	
• OPEN 24-V CONTROL CIRCUIT BREAKER(S)	
• COOLING LOAD SATISFIED	
• THERMISTOR FAILURE	
START-UP CHECKLIST FOR CHILLER SYSTEMS	CL-1 to CL-4

GENERAL

These installation instructions cover the 30HK, HL, HWA, HWB, HWC, and HWS units. The HL and HWA are condenserless units, and the HK, HWB, HWC, and HWS units are all fluid cooled. In addition, the 30HK and HWC units have a standard mechanically cleanable condenser and the 30HWS unit has a mechanically cleanable condenser specifically designed for sea coast applications.

SAFETY CONSIDERATIONS

Installing, starting up, and servicing this equipment (Fig. 1-3) can be hazardous due to system pressures, electrical components, and equipment location (roofs, elevated structures, etc.).

Only trained, qualified installers and service technicians should install, start up, and service this equipment.

When working on the equipment, observe precautions in the literature and on tags, stickers, and labels attached to the equipment.

- Follow all safety codes.
- Wear safety glasses and work gloves.
- Use care in handling, rigging, and setting bulky equipment.

⚠ WARNING

Be sure all power to equipment is shut off before performing maintenance or service. There may be more than one disconnect. Tag all disconnects to alert others not to turn on power until work is completed.

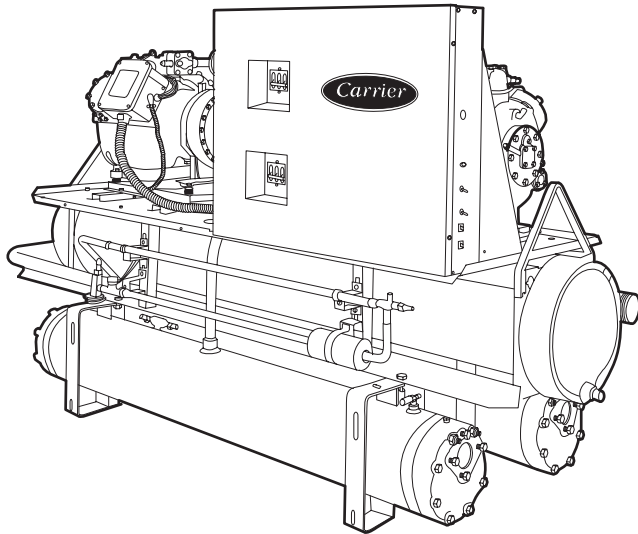

Fig. 1 — 30HK,HL Unit (30HK Shown)

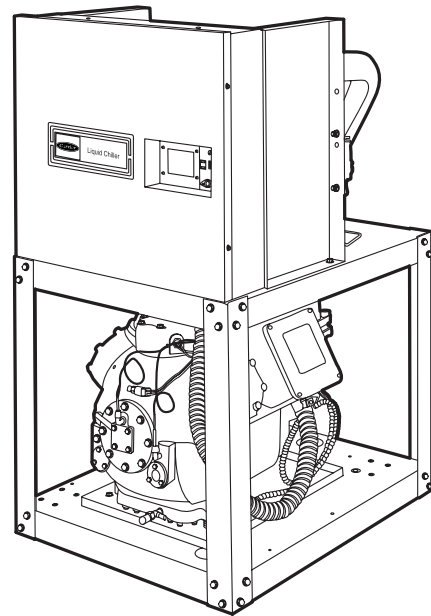

Fig. 2 — 30HWA,B Unit

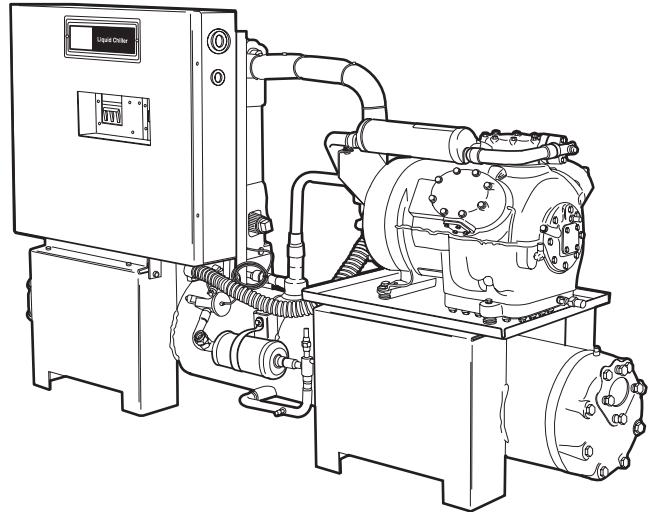

Fig. 3 — 30HWC,S Unit

INSTALLATION

Location — Do not store units in an area exposed to weather because of sensitive control mechanisms and electronic devices. Locate unit indoors. See Fig. 4-8 for unit dimensional details.

Allow 36 in. (914 mm) in front of the unit for control box access door. Compressor can be removed from either side or the front of the unit. Prior to installation determine which direction compressor will be removed, and leave 3 to 4 ft (914 to 1219 mm) clearance for removal.

On 30HK,HL units leave 7½ ft (2.3 m) (for 040 units) or 9 ft (2.7 m) (for 050,060 units) clearance on one side for cooler tube removal. Leave 2 ft (610 mm) clearance on the other side for making fluid connections to cooler and water connections to condenser. See Fig. 4 and 5.

On 30HWA,B units, leave 2 ft (610 mm) on one side for making fluid connections to cooler and water connections to condenser, accessing the thermostatic expansion valve (TXV), and replacing heat exchanger(s) if necessary. See Fig. 6 and 7.

On 30HWC,S units, leave 75 in. (1905 mm) on one side for condenser tube removal and 2 ft (610 mm) on the other side for making fluid connections to cooler and water connections to condenser, accessing the TXV, and replacing heat exchanger(s) if necessary. See Fig. 8.

The floor must be strong enough to support the unit operating weight (see Tables 1A-2B and Fig. 9 and 10). If necessary, add a supporting structure (steel beams or reinforced concrete slabs) to the floor to transfer weight to nearest beams.

Additional weights of factory-installed options (30HW only) are:

Sound enclosure — 75 lb (34 kg)

Hot gas bypass — 15 lb (7 kg)

80-amp non-fused disconnect — 15 lb (6.8 kg)

100-amp non-fused disconnect — 25 lb (11.3 kg)

200-amp non-fused disconnect — 70 lb (31.8 kg)

⚠ CAUTION

Be sure interconnecting piping and electrical conduits are suspended freely, and are not in contact with any adjacent walls. Be sure unit capillaries are not rubbing against anything.

Step 1 — Inspect Shipment — Inspect unit for damage or missing parts. If damaged, or if shipment is incomplete, file a claim immediately with the shipping company.

Step 2 — Rig and Place Unit

30HK,HL UNITS — On each end of cooler, a steel loop is provided for the preferred method of lifting unit. *Use spreader bars to keep cables away from compressor enclosure and control box.* If unit is to be moved by forklift truck, use one of the following two methods:

1. From front or rear, lift under the cooler rails. Unit can be either on or off skid.
2. When moving from the ends, *leave unit on the skid.* Lift from under the skid.

If unit is to be dragged into final position, or moved on rollers, it is recommended that it be left on the skid. *When dragging or rolling, apply force only to the skid, not to the unit.* Lift from above, using the lifting angles provided, to remove unit from the skid.

30HW UNITS

NOTE: If accessory mobility package (Carrier part no. 30HW900008) is to be used, install this accessory after bringing unit into building and before moving the unit to its final location per installation instructions provided with the accessory.

Units Equipped With Factory-Installed Unit Wheels — This factory-installed option consists of 4 swivel-type wheels mounted to the legs of the unit. See Fig. 11. For units equipped with this option, leave the skid on until the unit is *in the building.* Once in the building, remove the skid, and wheel the unit to its final location.

NOTE: The wheels are equipped with a thumb-screw brake.

Units Not Equipped With Factory-Installed Unit Wheels — Do not remove the skid until the unit has been moved to its final location. The unit may be moved by means of rollers under the skid, a forklift truck, or rig and slings.

Step 3 — Place the Unit

30HK,HL UNITS — When unit is in final position, remove skid, level the unit (using a level), and bolt the unit to floor or pad.

NOTE: *These units are not suitable for unprotected outdoor use.*

Carrier recommends that these units be located in the basement or on the ground floor. However, if it is necessary to locate the unit on an upper floor, be sure the structure has been designed to support the unit weight. If necessary, add structural support to floor. Also, be sure the surface for installation is level. Refer to Fig. 4 and 5 for space requirements and Fig. 9 for weight distribution.

Only electrical power connections, water connections for condenser, and fluid connections for cooler are required for 30HK installation. Installation of 30HL units varies only in field piping required for the remote condenser.

30HW UNITS — When the unit is in its final position, remove the skid (from units not equipped with factory-mounted wheels), or remove the wheels (if equipped). Remove ⅜-in. wheel nuts to remove wheels from unit legs. Level the unit (using a level), and bolt the unit to the floor or pad.

If unit is to be mounted on unit external vibration isolators, follow the mounting instructions included with the accessory vibration isolator (Carrier part numbers 30HW900-001 and -002).

Step 4 — Check Compressor Mounting and Connections

— As shipped, the compressor is held down by special self-locking nuts (Fig. 12). After unit is installed, loosen the self-locking nuts one at a time until compressor floats freely. Do not remove nuts, as they are self-locking and will hold their locked position.

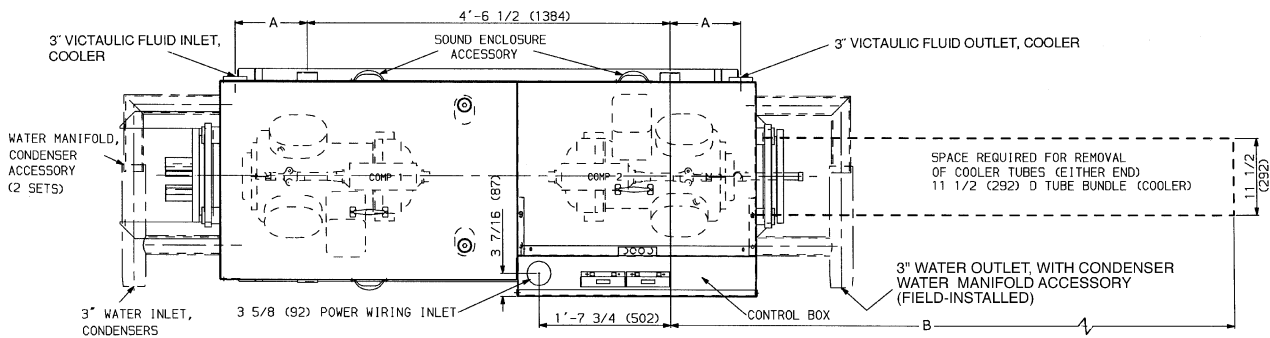

TOP VIEW

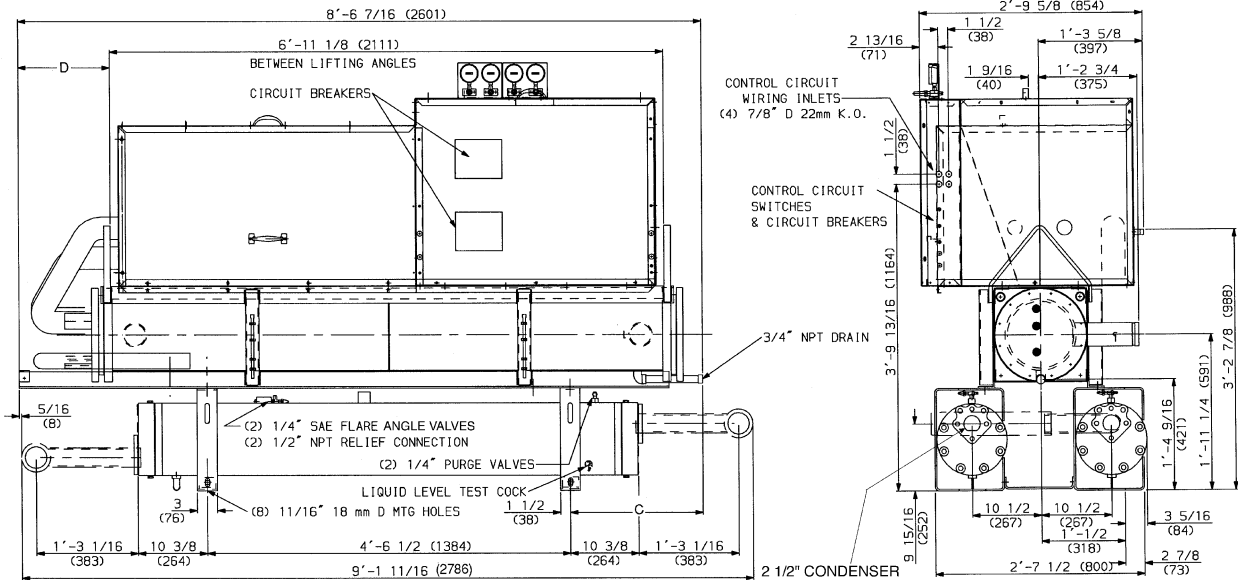

FRONT VIEW

RIGHT SIDE VIEW

UNIT 30HK	DIMENSIONS — in. (mm)			
	A	B	C	D
040	5 1/4 (133)	90 (2286)	14 9/16 (370)	7 15/16 (202)
050,060	10 3/4 (273)	108 (2743)	20 1/16 (510)	13 9/16 (344)

LEGEND

- COMP — Compressor
- K.O. — Knockout
- MTG — Mounting
- SAE — Society of Automotive Engineers (U.S.A.)

NOTES:

1. Standard unit shown with the sound enclosure accessory.
2. Dimensions are in inches unless otherwise indicated.
Dimensions in () are in millimeters.
3. Service clearance for the control box is 36-in.

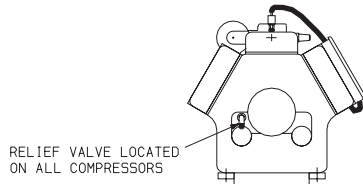

DETAIL B
TYP (2) PLACES
RELIEF VALVES ARE EQUIPPED WITH A 3/8\"/>

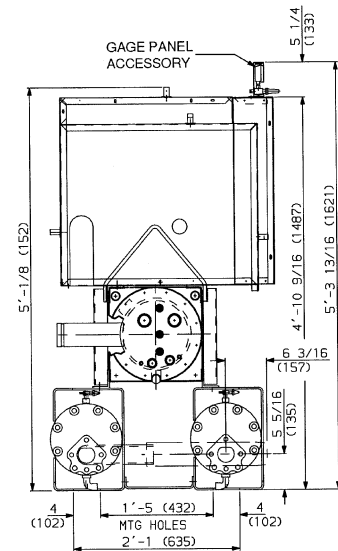

LEFT SIDE VIEW

Fig. 4 — 30HK040-060 (Fluid Cooled)

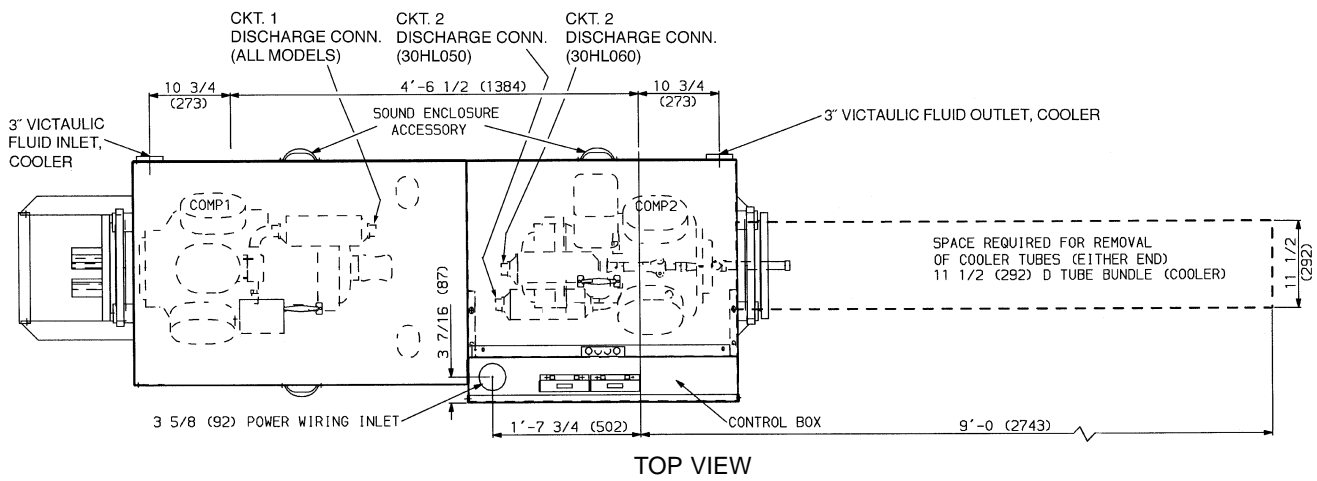

TOP VIEW

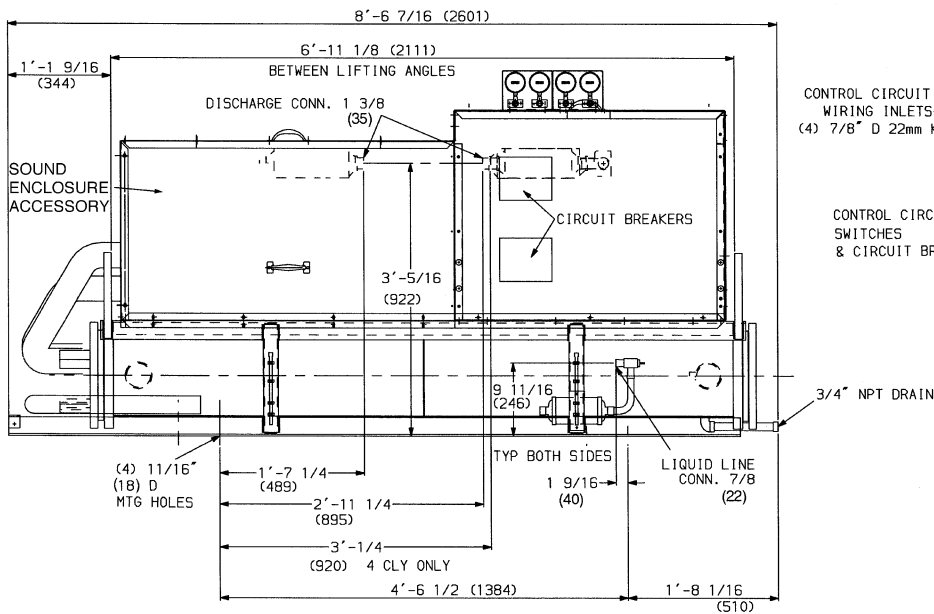

FRONT VIEW

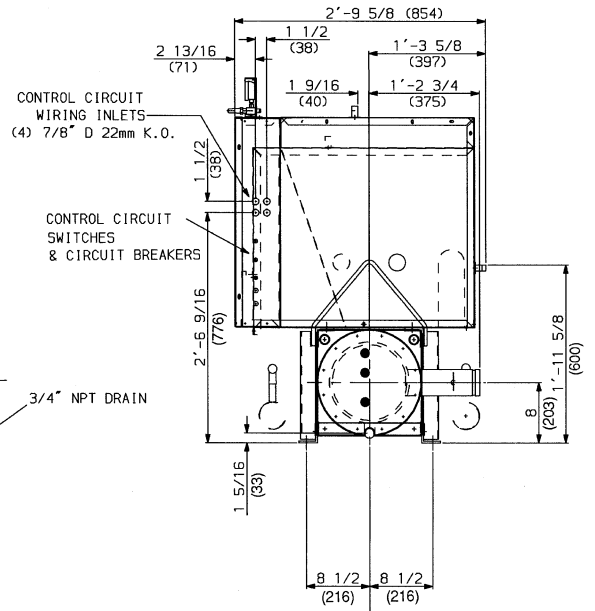

RIGHT SIDE VIEW

- LEGEND**
- CLY — Cylinder
 - COMP — Compressor
 - CONN — Connection
 - K.O. — Knockout

- NOTES:**
1. Standard unit shown with the sound enclosure accessory.
 2. Dimensions are in inches unless otherwise indicated. Dimensions in () are in millimeters.

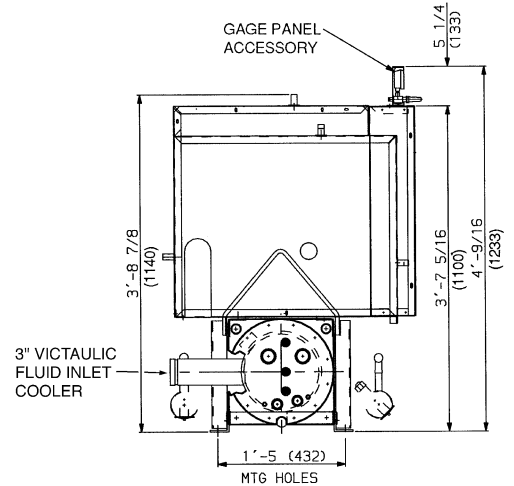
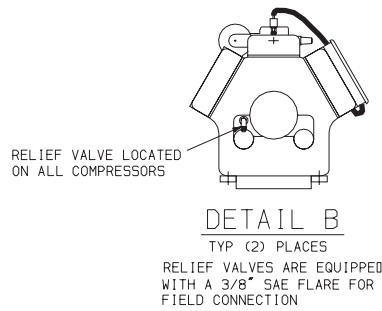

LEFT SIDE VIEW

Fig. 5 — 30HL050,060 (Condenserless)

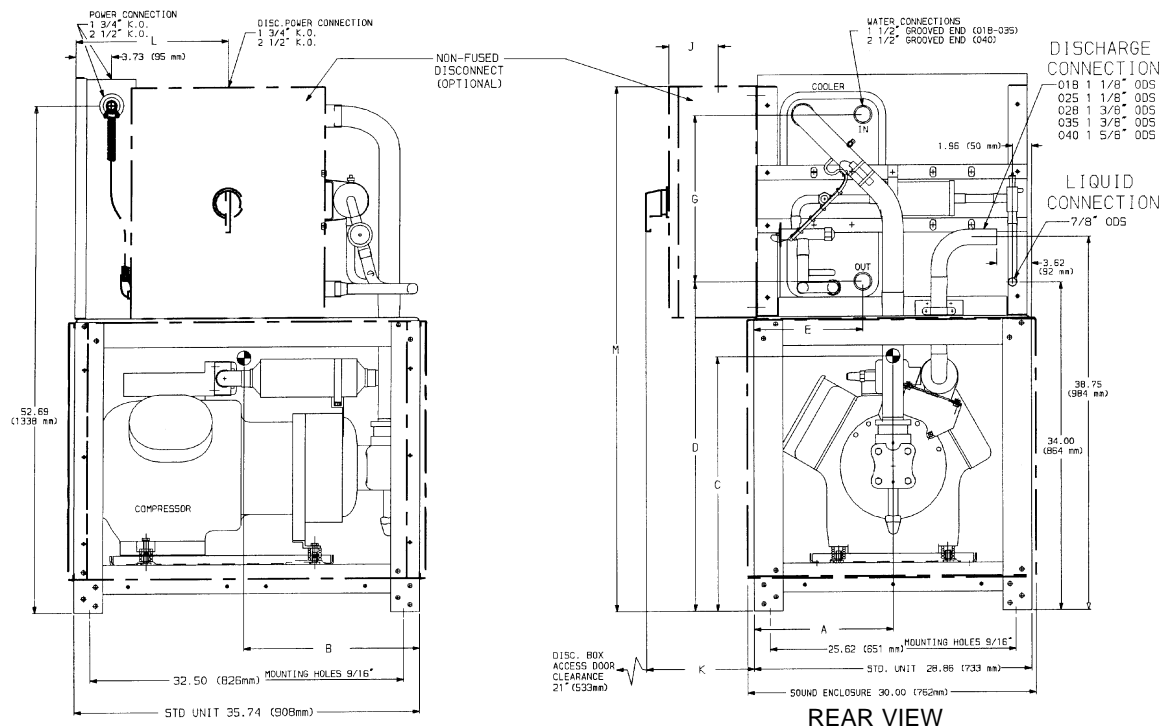

LEFT SIDE VIEW

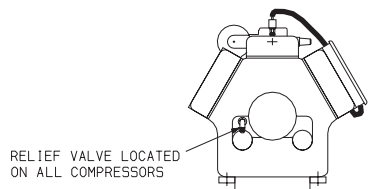

DETAIL B
TYP (2) PLACES

RELIEF VALVES ARE EQUIPPED WITH A 3/8\"/>

UNIT 30HWA	DIMENSIONS — in. (mm)						
	A	B	C	D	E	F	G
018	12.58 (320)	19.20 (488)	20.48 (520)	33.85 (860)	11.72 (298)	5.75 (146)	17.95 (456)
025	12.82 (326)	18.98 (482)	20.57 (522)	33.85 (860)	11.72 (298)	5.75 (146)	17.95 (456)
028	12.64 (321)	18.31 (465)	20.73 (527)	33.85 (860)	11.72 (298)	5.75 (146)	17.95 (456)
035	12.87 (327)	18.62 (473)	20.81 (529)	33.85 (860)	11.72 (298)	5.75 (146)	17.95 (456)
040	12.66 (322)	18.64 (473)	21.30 (541)	34.15 (867)	11.34 (288)	8.22 (209)	17.36 (441)

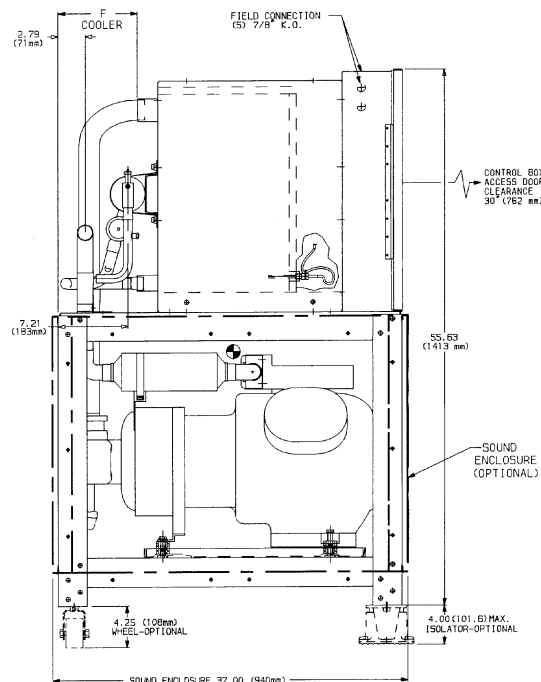

RIGHT SIDE VIEW

DISCONNECT (Amps)	LOCATION — in. (mm)				MODEL 30HWA (See Table Below)				
	J	K	L	M	018---	025---	028---	035---	040---
80	3.33 (85)	2.98 (76)	14.44 (367)	46.50 (1181)	100,200, 600,800,900	100,200, 600,900	100,200, 600,900	100,600,900	—
100	4.33 (110)	4.98 (126)	14.82 (376)	47.50 (1207)	500	500,800	800	200,800	100,200, 600,900
200	7.46 (189)	11.19 (284)	15.82 (402)	54.50 (1384)	—	—	500	500	500,800

LEGEND
DISC. — Disconnect
K.O. — Knockout

NOTES:
1. Denotes center of gravity.
2. - - - Denotes accessory or factory-installed option.
3. Dimensions are in inches. Dimensions in () are in millimeters.

MODEL	VOLT-Hz
100	575-60
200	380-60
500	208/230-60
600	460-60
800	230-50
900	400-50

Fig. 6 — 30HWA018-040 (Condenserless)

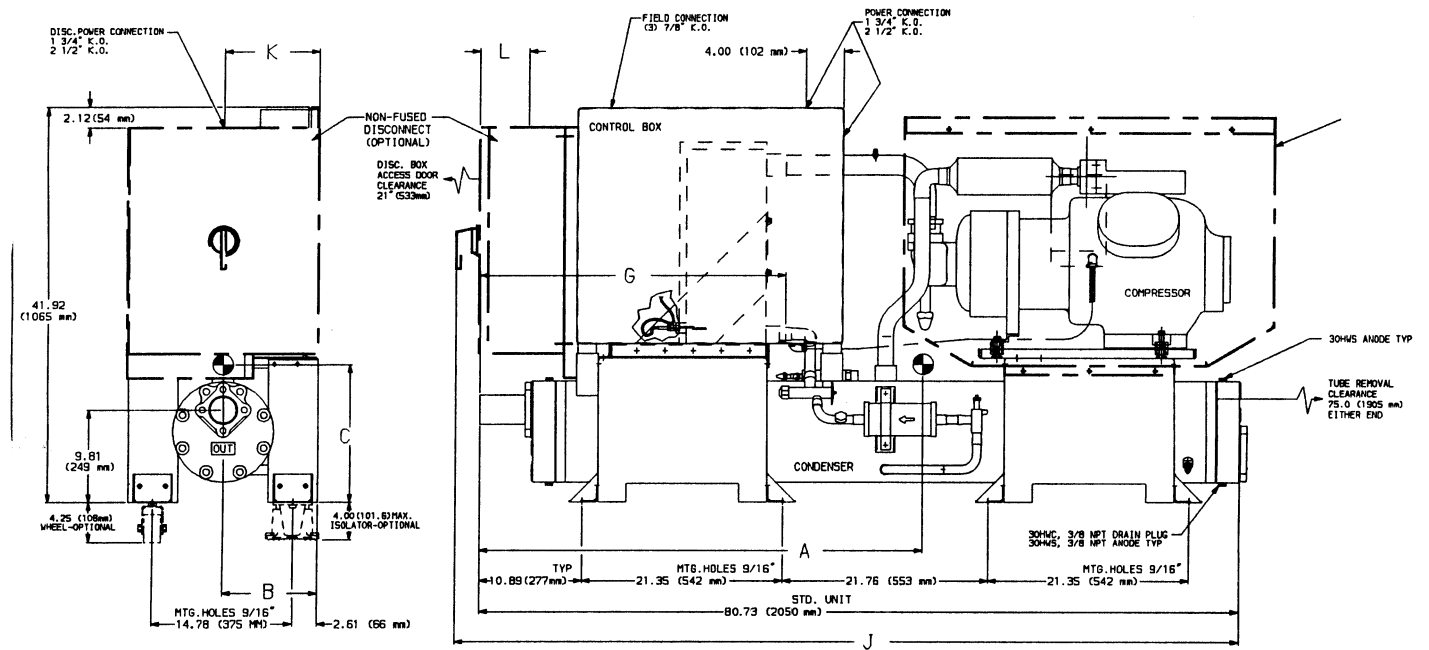

LEFT SIDE VIEW

FRONT VIEW

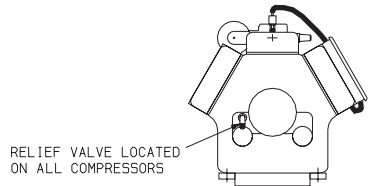

DETAIL B

TYP (2) PLACES

RELIEF VALVES ARE EQUIPPED WITH A 3/8" SAE FLARE FOR FIELD CONNECTION

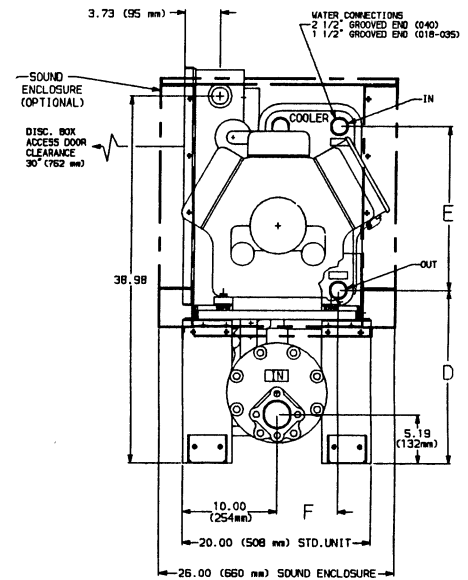

RIGHT SIDE VIEW

UNIT 30HWC,S	DIMENSIONS — in. (mm)						
	A	B	C	D	E	F	G
018	47.50 (1206)	9.90 (251)	14.00 (356)	18.15 (461)	17.95 (456)	6.69 (170)	34.20 (869)
025	48.30 (1227)	9.90 (251)	15.50 (394)	18.15 (461)	17.95 (456)	6.69 (170)	34.20 (869)
028	48.00 (1219)	10.00 (254)	15.80 (401)	18.15 (461)	17.95 (456)	6.69 (170)	34.20 (869)
035	48.20 (1224)	10.00 (254)	15.90 (404)	18.15 (461)	17.95 (456)	6.69 (170)	34.20 (869)
040	47.80 (1214)	10.00 (254)	15.90 (404)	18.45 (469)	17.36 (441)	6.40 (163)	32.94 (837)

DISCONNECT (Amps)	LOCATION — in. (mm)			MODEL 30HWC,S (See Table Below)				
	J	K	L	018---	025---	028---	035---	040---
80	77.61 (1971)	4.38 (111)	3.33 (85)	100,200, 600,800,900	100,200, 600,900	100,200, 600,900	100,200, 600,900	100
100	79.61 (2022)	5.00 (127)	4.33 (110)	500	500,800	500,800	800	200, 600,900
200	83.74 (2127)	10.00 (254)	7.46 (189)	—	—	—	500	500,800

LEGEND

- D. — Diameter
- Disc. — Disconnect
- K.O. — Knockout
- SCH.40 — Schedule 40 Pipe

NOTES:

1. Denotes center of gravity.
2. - - - - Denotes accessory or factory-installed option.
3. Dimensions are in inches. Dimensions in () are in millimeters.

MODEL	VOLT-Hz
100	575-60
200	380-60
500	208/230-60
600	460-60
800	230-50
900	400-50

Fig. 8 — 30HWC,S018-040 (Fluid Cooled)

WEIGHT DISTRIBUTION AT EACH MOUNTING HOLE, 60 HZ UNITS

UNIT SIZE	MOUNTING HOLES															
	30HK								30HL							
	A		B		C		D		A		B		C		D	
	Lb	Kg	Lb	Kg	Lb	Kg	Lb	Kg	Lb	Kg	Lb	Kg	Lb	Kg	Lb	Kg
040	710	322	712	323	705	320	703	319	—	—	—	—	—	—	—	—
050	787	357	789	358	782	355	780	354	519	235	521	236	516	234	514	233
060	838	380	840	381	832	377	830	376	534	242	536	243	531	241	529	240

NOTE: See Fig. 4 and 5 for specific mounting hole location dimensions.

WEIGHT DISTRIBUTION AT EACH MOUNTING HOLE, 50 HZ UNITS

UNIT SIZE	MOUNTING HOLES															
	30HK								30HL							
	A		B		C		D		A		B		C		D	
	Lb	Kg	Lb	Kg	Lb	Kg	Lb	Kg	Lb	Kg	Lb	Kg	Lb	Kg	Lb	Kg
040	721	327	723	328	716	325	715	325	—	—	—	—	—	—	—	
050	838	380	840	381	832	377	830	376	534	242	526	238	531	241	529	240
060	853	387	855	388	847	384	845	383	550	249	551	250	545	247	544	247

NOTE: See Fig. 4 and 5 for specific mounting hole location dimensions.

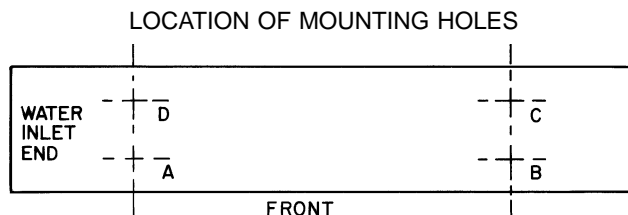
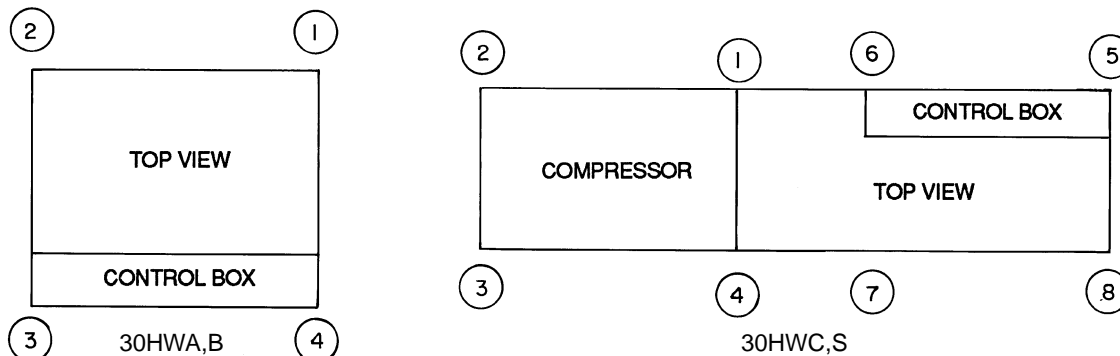

Fig. 9 — Weight Distribution and Mounting Hole Location; 30HK,HL Units



WEIGHT DISTRIBUTION AT EACH MOUNTING HOLE — Lb (kg)

UNIT 30HW	MOUNTING HOLE NO.							
	1	2	3	4	5	6	7	8
A018		185 (83.9)						
A025		220 (99.8)						
A028		240 (108.9)						
A035		244 (110.7)						
A040		270 (122.5)						
B018		199 (90.3)						
B025		238 (108.0)						
B028		266 (120.7)						
B035		271 (122.9)						
B040		328 (148.8)						
C,S018		171 (77.6)				136 (61.7)		
C,S025		196 (88.9)				144 (65.3)		
C,S028		211 (95.7)				160 (72.6)		
C,S035		216 (98.0)				161 (73.0)		
C,S040		240 (108.9)				185 (83.9)		

Fig. 10 — Mounting Hole Weight Distribution; 30HW Units

Table 1A — Physical Data; 30HK, HWB, HWC, and HWS Fluid-Cooled Units — English

UNIT 30	HW-018*	HW-025*	HW-028*	HW-035*	HW-040*	HK040	HK050	HK060
OPERATING WT (Approximate) – lb								
HWB	795	950	1065	1085	1310	—	—	—
HWC,S	1231	1358	1484	1508	1702	—	—	—
HK	—	—	—	—	—	2830/ 2875†	3138/ 3340†	3340/ 3400†
REFRIGERANT — lb								
HWB	12.5	15.0	17.5	18.5	23.2	—	—	—
HWC,S	35.0	37.0	42.0	42.0	47.0	—	—	—
HK — Ckt 1	—	—	—	—	—	35/40†	45/45†	45/45†
HK – Ckt 2	—	—	—	—	—	35/35†	35/45†	45/45†
COMPRESSOR								
Model No.	06DG537	06E2150**	06E7265	06E7175**	06E7299	06E2150	06E6175, 06E2150	06E6175
Nominal Hp	15	20	25	30	35	20 (ea)	20,30	30 (ea)
Quantity	1	1	1	1	1	2	1 (ea)	2
Cylinders Per Compressor	6	4	6	6	6	4 (ea)	6,4	6 (ea)
Capacity Control — Standard								
No. of Steps	3	2	3	3	3	4	4	4
Minimum Step Capacity (%)	33	50	33	33	33	25	20††	33
Capacity Control — With Optional Hot Gas Bypass								
No. of Steps	4	3	4	4	4	5	5	5
Minimum Step Capacity (%)	10	10	10	10	10	10	10	10
Relief Valve Flow Rate — lb air/min	—	15.1	15.1	15.1	15.1	15.1	15.1	15.1
COOLER								
Part No.	LL01SB006	LL01SB007	LL01SB009	LL01SB009	LL01SC005	10HA400654	10HA400664	10HA400664
Dry Weight — lb	69	81	105	105	145	657	726	726
Fluid Side — psig	300	300	300	300	300	150	150	150
Refrigerant Side — psig	430	430	430	430	430	235	235	235
Net Fluid Volume — Gal. (includes nozzles)	1.4	1.6	2.1	2.1	3.3	13.1	15.2	15.2
Fluid Connections — in.								
Inlet	1½	1½	1½	1½	2½	3	3	3
Outlet	1½	1½	1½	1½	2½	3	3	3
CONDENSER								
30HWB (Water Cooled)								
Part No. LL01S-	D001	D002	D003	D004	E004	—	—	—
Dry Weight — lb	48	62	79	87	153	—	—	—
Water Side — psig	300	300	300	300	300	—	—	—
Refrigerant Side — psig	430	430	430	430	430	—	—	—
Net Water Volume — Gal. (includes nozzles)	0.9	1.2	1.6	1.8	3.3	—	—	—
Water Connections — in.								
Inlet	1½	1½	1½	1½	2½	—	—	—
Outlet	1½	1½	1½	1½	2½	—	—	—
30HWC (Water Cooled)								
Part No. 09RW-	400007	400007	400011	400011	400009	—	—	—
Dry Weight — lb	532	532	560	560	624	—	—	—
Water Side — psig	300	300	300	300	300	—	—	—
Refrigerant Side — psig	365	365	365	365	365	—	—	—
Net Water Volume — Gal.	2.6	2.6	4.0	4.0	7.3	—	—	—
Relief Valve Flow Rate — lb air/min	24.6	24.6	24.6	24.6	24.6	—	—	—
Water Connections — in.								
Inlet	2½	2½	2½	2½	2½	—	—	—
Outlet	2½	2½	2½	2½	2½	—	—	—
30HWS (Water Cooled)								
Part No. 09RW-	400017	400017	400019	400019	400018	—	—	—
Dry Weight — lb	532	532	560	560	624	—	—	—
Water Side — psig	300	300	300	300	300	—	—	—
Refrigerant Side — psig	335	335	335	335	335	—	—	—
Net Water Volume — Gal.	2.6	2.6	4.0	4.0	7.3	—	—	—
Relief Valve Flow Rate — lb air/min	22.6	22.6	22.6	22.6	22.6	—	—	—
Water Connections — in.								
Inlet	2½	2½	2½	2½	2½	—	—	—
Outlet	2½	2½	2½	2½	2½	—	—	—
30HK (Water Cooled)								
Part No. 09RP-	—	—	—	—	—	022/022†	022/027†	027/027†
Dry Weight — lb	—	—	—	—	—	1000	1095	1190
Water Side — psig	—	—	—	—	—	250	250	250
Refrigerant Side — psig	—	—	—	—	—	385	385	385
Net Water Volume — Gal. (includes nozzles)	—	—	—	—	—	4.4/4.4†	4.4/5.2†	5.2/5.2†
Relief Valve Flow Rate — lb air/min	—	—	—	—	—	25.9	25.9	25.9
Water Connections — in.								
Inlet	—	—	—	—	—	2½	2½	2½
Outlet	—	—	—	—	—	2½	2½	2½

LEGEND

ODS — Outside Diameter, Sweat

*Unless otherwise noted, data is for HWB, HWC, and HWS units.

†60 Hz/50 Hz units.

**For 025 50 Hz units, compressor number is 06E2250, for 035 50 Hz units compressor number is 06E7275.

††With transfer switch set to compressor no. 2 position; 40% with transfer switch set to compressor no. 1 position.

NOTES:

1. Operating weight includes refrigerant operating charge and weight of fluid in the heat exchangers.

2. 30HK,HWB,HWC, and HWS units are shipped with full operating charge.

Table 1B — Physical Data; 30HK, HWB, HWC, and HWS Fluid-Cooled Units — SI

UNIT 30	HW-018*	HW-025*	HW-028*	HW-035*	HW-040*	HK040	HK050	HK060
OPERATING WT (Approximate) – kg								
HWB	360	431	483	492	594	—	—	—
HWC,S	554	611	668	679	766	—	—	—
HK	—	—	—	—	—	1284/ 1305†	1424/ 1514†	1514/ 1542†
REFRIGERANT — kg				R-22				
HWB	5.7	6.8	7.9	8.4	10.5	—	—	—
HWC,S	15.9	16.8	19.1	19.1	21.3	—	—	—
HK — Ckt 1	—	—	—	—	—	15.9/18.1†	20.4/20.4†	20.4/20.4†
HK — Ckt 2	—	—	—	—	—	15.9/15.9†	15.9/20.4†	20.4/20.4†
COMPRESSOR								
Model No.	06DG537	06E2150**	06E7265	06E7175**	06E7299	06E2150	06E6175, 06E2150	06E6175
Nominal kW	11.1	14.9	18.7	22.4	26.1	14.9 (ea)	330 14.9,22.4	22.4 (ea)
Quantity	1	1	1	1	1	2	1 (ea)	2
Cylinders Per Compressor	6	4	6	6	6	4 (ea)	6,4	6 (ea)
Capacity Control — Standard								
No. of Steps	3	2	3	3	3	4	4	4
Minimum Step Capacity (%)	33	50	33	33	33	25	20††	33
Capacity Control — With Hot Gas Bypass								
No. of Steps	4	3	4	4	4	5	5	5
Minimum Step Capacity (%)	10	10	10	10	10	10	10	10
Relief Valve Flow Rate — kg air/min	—	6.8	6.8	6.8	6.8	6.8	6.8	6.8
COOLER								
Part No.	LL01SB006	LL01SB007	LL01SB009	LL01SB009	LL01SC005	10HA400654	10HA400664	10HA400664
Dry Weight — kg	31.3	36.7	47.6	47.6	65.7	297	330	330
Fluid Side — kPa	2069	2069	2069	2069	2069	1034	1034	1034
Refrigerant Side — kPa	2965	2965	2965	2965	2965	1620	1620	1620
Net Fluid Volume — L (includes nozzles)	5.3	6.1	8.0	8.0	12.5	49.9	57.5	57.5
Fluid Connections — in.					Grooved End			
Inlet	1½	1½	1½	1½	2½	3	3	3
Outlet	1½	1½	1½	1½	2½	3	3	3
CONDENSER								
30HWB (Water Cooled)								
Part No. LL01S-	D001	D002	D003	D004	E004	—	—	—
Dry Weight — kg	21.8	28.1	35.8	39.5	69.4	—	—	—
Water Side — kPa	2069	2069	2069	2069	2069	—	—	—
Refrigerant Side — kPa	2965	2965	2965	2965	2965	—	—	—
Net Water Volume — L (includes nozzles)	3.4	4.5	6.1	6.8	12.5	—	—	—
Water Connections — in.					Grooved End			
Inlet	1½	1½	1½	1½	2½	—	—	—
Outlet	1½	1½	1½	1½	2½	—	—	—
30HWC (Water Cooled)								
Part No. 09RW-	400007	400007	400011	400011	400009	—	—	—
Dry Weight — kg	241	241	254	254	283	—	—	—
Water Side — kPa	2069	2069	2069	2069	2069	—	—	—
Refrigerant Side — kPa	2517	2517	2517	2517	2517	—	—	—
Net Water Volume — L	9.8	9.8	15.4	15.4	27.6	—	—	—
Relief Valve Flow Rate — kg air/min	11.2	11.2	11.2	11.2	11.2	—	—	—
Water Connections — in.					Weld			
Inlet	2½	2½	2½	2½	2½	—	—	—
Outlet	2½	2½	2½	2½	2½	—	—	—
30HWS (Water Cooled)								
Part No. 09RW-	400017	400017	400019	400019	400018	—	—	—
Dry Weight — kg	241	241	254	254	283	—	—	—
Water Side — kPa	2069	2069	2069	2069	2069	—	—	—
Refrigerant Side — kPa	2310	2310	2310	2310	2310	—	—	—
Net Water Volume — L	9.8	9.8	15.4	15.4	27.6	—	—	—
Relief Valve Flow Rate — kg air/min	10.3	10.3	10.3	10.3	10.3	—	—	—
Water Connections — in.					Weld			
Inlet	2½	2½	2½	2½	2½	—	—	—
Outlet	2½	2½	2½	2½	2½	—	—	—
30HK (Water Cooled)								
Part No. 09RP-	—	—	—	—	—	022/022†	022/027†	027/027†
Dry Weight — kg	—	—	—	—	—	454	497	540
Water Side — kPa	—	—	—	—	—	1724	1724	1724
Refrigerant Side — kPa	—	—	—	—	—	2655	2655	2655
Net Water Volume — L (includes nozzles)	—	—	—	—	—	17/17†	17/20†	20/20†
Relief Valve Flow Rate — kg air/min	—	—	—	—	—	11.7	11.7	11.7
Water Connections — in.					Weld			
Inlet	—	—	—	—	—	2½	2½	2½
Outlet	—	—	—	—	—	2½	2½	2½

LEGEND

ODS — Outside Diameter, Sweat

*Unless otherwise noted, data is for HWB, HWC, and HWS units.

†60 Hz/50 Hz units.

**For 025 50 Hz units, compressor number is 06E2250, for 035 50 Hz units compressor number is 06E7275.

††With transfer switch set to compressor no. 2 position; 40% with transfer switch set to compressor no. 1 position.

NOTES:

1. Operating weight includes refrigerant operating charge and weight of fluid in the heat exchangers.

2. 30HK,HWB,HWC, and HWS units are shipped with full operating charge.

Table 2A — Physical Data; 30HL, HWA Condenserless Units — English

UNIT 30	HWA018	HWA025	HWA028	HWA035	HWA040	HL050	HL060
OPERATING WT (Approximate) – lb	740	880	960	975	1080	2070/ 2120*	2130/ 2190*
REFRIGERANT† — lb	R-22						
	1.6	2.0	2.4	2.4	3.0	6.3/4.2**	5.3/5.3**
COMPRESSOR							
Model No.	06DG537	06E2250	06E7265	06E7275	06E7299	06E6275, 06E2250	06E6275
Nominal Hp	15	20	25	30	35	25,20	30 (ea)
Quantity	1	1	1	1	1	1 (ea)	2
Cylinders Per Compressor	6	4	6	6	6	6,4	6
Capacity Control — Standard							
No. of Steps	3	2	3	3	3	4	4
Minimum Step Capacity (%)	33	50	33	33	33	20††	33
Capacity Control — With Optional Hot Gas Bypass							
No. of Steps	4	3	4	4	4	5	5
Minimum Step Capacity (%)	10	10	10	10	10	10	10
Relief Valve Flow Rate — lb air/min	—	15.1	15.1	15.1	15.1	15.1	15.1
COOLER							
Part No.	LL01SB006	LL01SB007	LL01SB009	LL01SB009	LL01SC005	10HA400654	10HA400664
Dry Weight — lb	69	81	105	105	145	726	726
Fluid Side — psig	300	300	300	300	300	150	150
Refrigerant Side — psig	430	430	430	430	430	235	235
Net Fluid Volume — Gal. (includes nozzles)	1.4	1.6	2.1	2.1	3.3	13.1	15.2
Fluid Connections — in.				Grooved End			
Inlet	1½	1½	1½	1½	2½	3	3
Outlet	1½	1½	1½	1½	2½	3	3
CONDENSER CONNECTIONS							
Refrigerant Connections — in.							
Liquid Line ODS	7/8	7/8	7/8	7/8	7/8	7/8	7/8
Discharge Line ODS	1½	1½	1½	1½	1½	1½	1½

LEGEND

ODS — Outside Diameter, Sweat

*60 Hz/50 Hz units.

†30HWA and HL units (condenserless) are shipped with a refrigerant holding charge. Approximate cooler operating charge is shown.

**Ckt 1/Ckt 2.

††With transfer switch set to compressor no. 2 position; 40% with transfer switch set to compressor no. 1 position.

NOTE: Operating weight includes refrigerant operating charge and weight of fluid in the heat exchangers.

Table 2B — Physical Data; 30HL, HWA Condenserless Units — SI

UNIT 30	HWA018	HWA025	HWA028	HWA035	HWA040	HL050	HL060
OPERATING WT (Approximate) – kg	335	399	435	442	490	938/ 961†	966/ 993†
REFRIGERANT† — kg	R-22						
	0.7	0.9	1.1	1.1	1.4	2.9/1.9**	2.4/2.4**
COMPRESSOR							
Model No.	06DG537	06E2250	06E7265	06E7275	06E7299	06E6275, 06E2250	06E6175
Nominal kW	11.2	14.9	18.7	22.4	26.1	18.7,14.9	22.4 (ea)
Quantity	1	1	1	1	1	1 (ea)	2
Cylinders Per Compressor	6	4	6	6	6	6,4	6
Capacity Control — Standard							
No. of Steps	3	2	3	3	3	4	4
Minimum Step Capacity (%)	33	50	33	33	33	20††	33
Capacity Control — With Optional Hot Gas Bypass							
No. of Steps	4	3	4	4	4	5	5
Minimum Step Capacity (%)	10	10	10	10	10	10	10
Relief Valve Flow Rate — kg air/min	—	6.8	6.8	6.8	6.8	6.8	6.8
COOLER							
Part No.	LL01SB006	LL01SB007	LL01SB009	LL01SB009	LL01SC005	10HA400654	10HA400664
Dry Weight — kg	31.3	36.7	47.6	47.6	65.7	330	330
Fluid Side — kPa	2069	2069	2069	2069	2069	1034	1034
Refrigerant Side — kPa	2965	2965	2965	2965	2965	1620	1620
Net Fluid Volume — L (includes nozzles)	5.3	6.1	8.0	8.0	12.5	49.9	57.5
Fluid Connections — in.				Grooved End			
Inlet	1½	1½	1½	1½	2½	3	3
Outlet	1½	1½	1½	1½	2½	3	3
CONDENSER CONNECTIONS							
Refrigerant Connections — in.							
Liquid Line ODS		7/8		7/8	7/8	7/8	7/8
Discharge Line ODS		1½		1½	1½	1½	1½

LEGEND

ODS — Outside Diameter, Sweat

*60 Hz/50 Hz units.

†30HWA and HL units (condenserless) are shipped with a refrigerant holding charge. Approximate cooler operating charge is shown.

**Ckt 1/Ckt 2.

††With transfer switch set to compressor no. 2 position; 40% with transfer switch set to compressor no. 1 position.

NOTE: Operating weight includes refrigerant operating charge and weight of fluid in the heat exchangers.

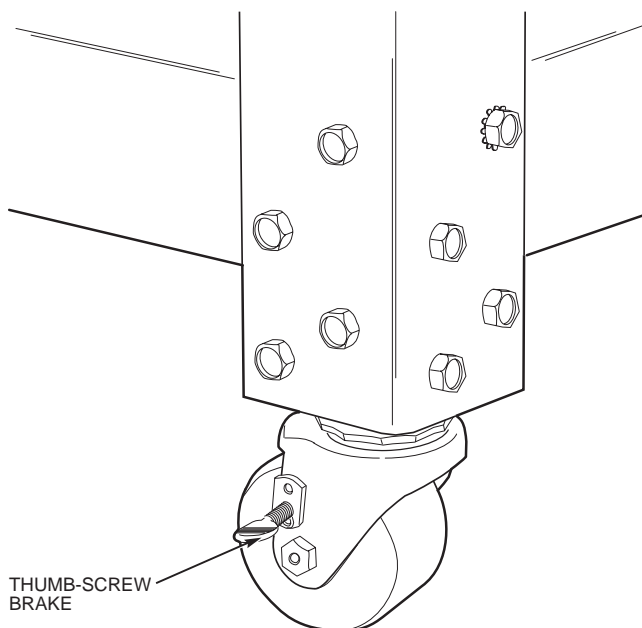

Fig. 11 — Factory-Installed Unit Wheels (4)

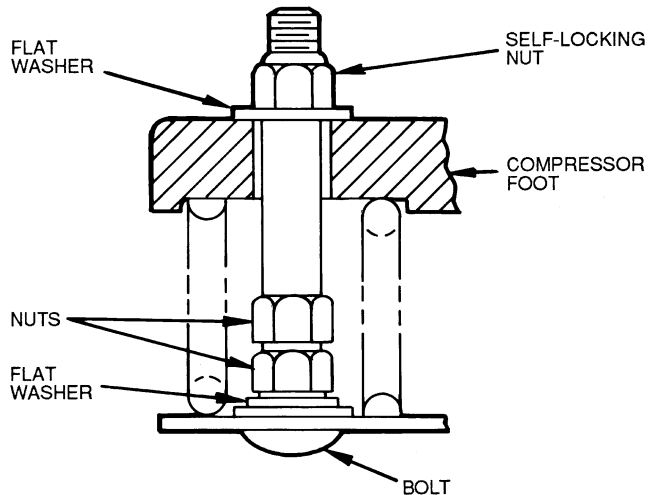

Fig. 12 — Compressor Mounting

Step 5 — Make Piping Connections — See Fig. 13 and 14 for typical piping applications.

30HK, HWC, HWS CONDENSER DESCRIPTION — All 30HWC and HWS units use a shell-and-tube condenser with removable heads for easy tube servicing. Refrigerant is contained within the shell, and water flows through the tubes. The 30HK and HWC units use a steel shell condenser(s) with steel tube sheets and copper tubes. The 30HWS units are designed for sea coast applications and use a steel shell condenser with cupronickel tube sheets and tubes. In addition, the 30HWS water heads utilize “sacrificial” zinc anodes for condenser corrosion protection.

IMPORTANT: Inspect the zinc anodes every 3 months for deterioration and replace as needed. Galvanic protection of the condenser is lost if the anodes are not replaced prior to complete deterioration.

The number of tubes in the condenser(s) varies depending on the unit size. The condensers have internal subcoolers which provide approximately 8 F (4.4 C) for 30HK, HL units or 13 F (7.2 C) for 30HW units subcooling at ARI (Air Conditioning and Refrigeration Institute, U.S.A.) rating conditions.

30HL, HWA SYSTEM CONDENSER — For detailed condenser piping installation instructions for 30HL and HWA systems, refer to separate instructions packaged with the remote condenser unit(s).

Condenser refrigerant piping for 30HL and HWA units should be sized to minimize the amount of refrigerant required.

The 30HL and HWA units that use an air-cooled evaporative condenser(s) must have adequate means for head pressure control when operating below 60 F (15.6 C).

Carrier recommends that a field-supplied pressure relief device be installed after the muffler in each discharge line. Most local codes require the relief valve to be vented directly to the outdoors. The vent **must not** be smaller than the relief valve outlet.

30HWP CONDENSER DESCRIPTION — All 30HWP units use a brazed-plate heat-exchanger-type condenser. These heat exchangers are made of embossed plates of acid-resistant stainless steel. Every other plate is reversed so that the ridges of the herringbone pattern intersect one another on adjacent plates, forming a lattice of contact points. These plates are vacuum-brazed together to form a compact and pressure-resistant heat exchanger.

After brazing, the impressions in the plates form 2 separate systems of channels where the refrigerant and water flows are counter-current. The number of plates varies depending on unit tonnage. The condensers provide approximately 14° to 18° F (8° to 10° C) liquid subcooling at the standard Air Conditioning and Refrigeration Institute (ARI) rating condition.

30HK, HWC, HWS CONDENSER(S) — When facing the front of the unit, the condenser(s) is in the uninsulated shell(s) located across the bottom of the unit. The water connections are such that the water inlet is located on the left-hand side (30HK) or right-hand side (30HW) of the unit. The water inlet must **ALWAYS** be on the bottom of the condenser(s) to provide the proper subcooling. The water outlet is located on the right-hand side (30HK) or left-hand side (30HW) of the unit. The water connections can be reversed by rotating the heads and gaskets 180 degrees **ON BOTH ENDS OF THE CONDENSER(S)**.

IMPORTANT: THE WATER INLET MUST ALWAYS BE ON THE CONDENSER HEAD(S) THAT HAS THE NOZZLE CONNECTION AT THE BOTTOM OF THE HEAD. Incorrect inlet connection will result in poor system performance due to incorrect subcooling.

The LIQUID-IN and LIQUID-OUT labels indicate water connections AS SUPPLIED FROM THE FACTORY.

It is recommended that strainer with a minimum of 20 mesh be installed ahead of the condenser water inlet(s) to prevent debris from clogging or damaging the heat exchanger(s).

There is a pressure-relief device on the condenser(s) of all 30HK, HWC, and HWS units. Most local codes require that this relief be vented directly to the outdoors.

NOTE: The relief line **must not** be smaller than the relief valve outlet. Be sure to provide a way of draining and servicing the unit.

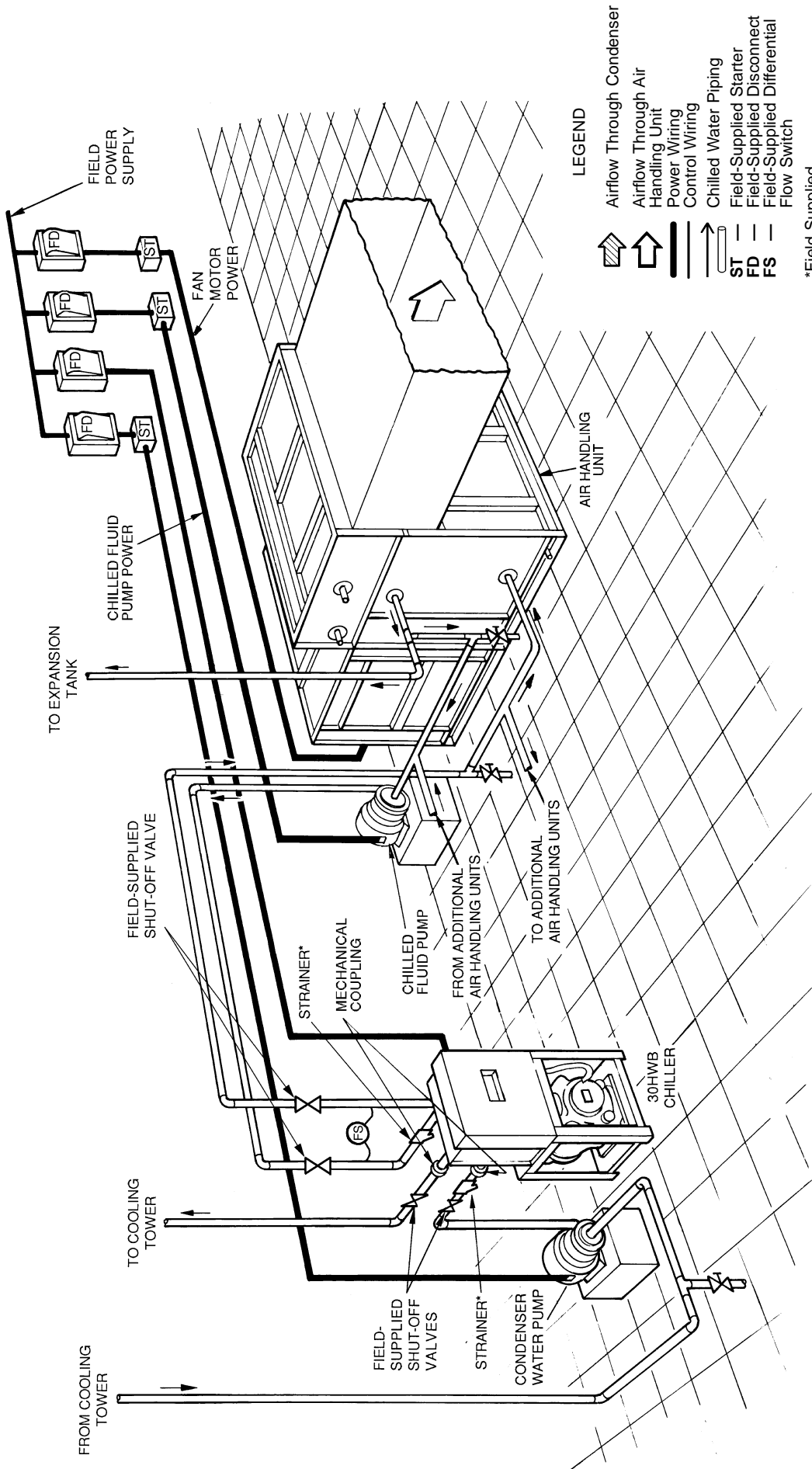

NOTES:

1. Chiller must be installed levelly to maintain proper compressor oil return.
2. Wiring and piping shown are general points-of-connection guides only and are not intended for a specific installation. Wiring and piping shown are for a quick overview of system and are not in accordance with recognized standards.
3. All wiring must comply with applicable local and national codes.
4. All piping must follow standard piping techniques. Refer to Carrier System Design Manual or appropriate ASHRAE (American Society of Heating, Refrigeration, and Air Conditioning Engineers) handbook for details.
5. See Table 3 on page 17 for minimum system fluid volume. This system may require the addition of a holding tank to ensure adequate volume.

Fig. 13 — Typical Piping with Fluid-Cooled 30HWP Unit Shown

NOTES:

1. Chiller must be installed *levelly* to maintain proper compressor oil return.
2. Wiring and piping shown are general points-of-connection guides only and are not intended for a specific installation. Wiring and piping shown are for a quick overview of system and are not in accordance with recognized standards.
3. All wiring must comply with applicable local and national codes.
4. All piping must follow standard piping techniques. Refer to Carrier System Design Manual part 3, Carrier E20-II® software Refrigerant Piping program, or appropriate ASHRAE (American Society of Heating, Refrigeration, and Air Conditioning Engineers) handbook for details on proper piping sizes and design.
5. See Table 3 on page 17 for minimum system fluid volume. This system may require the addition of a holding tank to ensure adequate volume.
6. Hot gas lines should rise above refrigerant level in condenser circuit. Double riser may be required; check compressor minimum capacity.
7. Trap should be installed on hot gas lines to prevent condenser oil and refrigerant vapor migration from accumulating on compressor heads during off cycle.
8. Pitch all horizontal lines downward in the direction of refrigerant flow.
9. For piping lengths greater than 50 ft, provide support to liquid and gas lines near the connections to the condenser coil.
10. For pressure relief requirements, see latest revision of ASHRAE Standard 15, Safety Code for Mechanical Refrigeration.

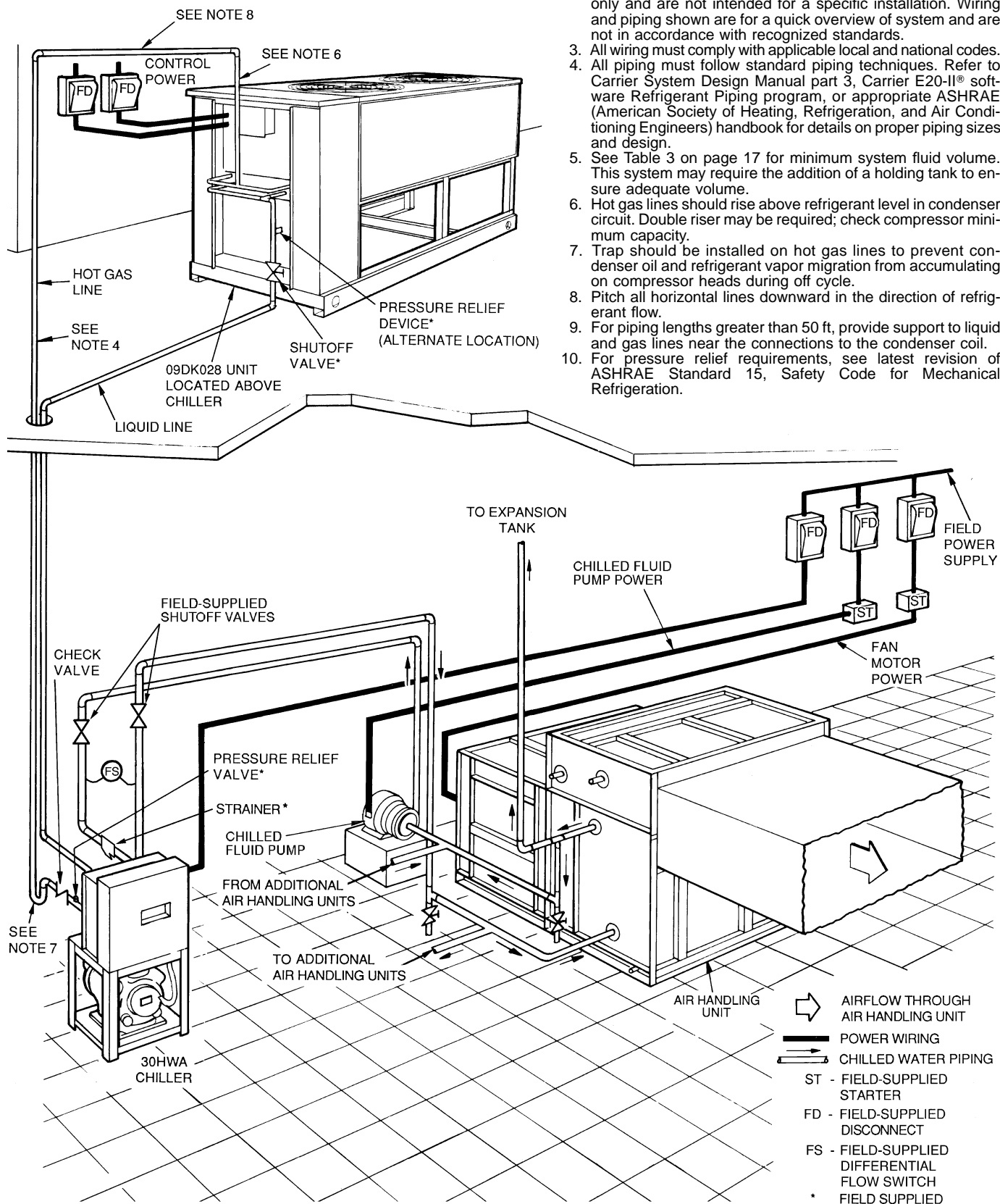

Fig. 14 — Typical Piping with Air-Cooled 30HWA with Remote 09DK Unit Shown

30HWB CONDENSER — When facing the back of the unit, the condenser is the uninsulated heat exchanger located on the right-hand side. The water connections are on the right-hand side of the heat exchanger with the LIQUID-IN connection at the bottom, and the LIQUID-OUT connection at the top.

A strainer with a minimum of 20 mesh **must** be installed ahead of the condenser water inlet to prevent debris from clogging or damaging the heat exchanger.

To install the grooved end coupling (see Fig. 15):

1. Lubricate the gasket lips and stretch the gasket over the end of the pipe. Avoid twisting the gasket when installing.
2. Bring the pipe and heat exchanger coupling ends together into alignment. Slide the gasket so that it is centered over the ends. Apply a light film of lubricant to the gasket, or to the gasket recess of the coupling housing. Avoid twisting the gasket during installation.
3. Seat the coupling halves over the gasket and install the nuts and bolts. Tighten the nuts equally on both sides.
4. Alternately tighten the nuts with a wrench to draw the coupling halves together uniformly. The joint is now complete.

30HK, HWB, HWC, HWS UNITS — In order to minimize the water pressure drop in the system, use as few bends as possible in the field water piping, and run the lines as short as possible. Size the water lines according to the available pump pressure (not necessarily the connection size), especially on cooling tower applications. See Carrier System Design Manual, Part 3, Piping Design. See Fig. 16 for condenser pressure drops.

Set water regulating valve to maintain design head pressure. Do not adjust to compensate for high head pressures caused by fouled condenser tubes, excess refrigerant, or the presence of noncondensables. Due to changes in water temperature, it may be necessary to adjust the valve seasonally. After adjusting for design head pressure, shut unit down. The water regulating valve should shut off the flow of water in a few minutes. If it does not, raise head pressure setting. Make sure that the capillary tube from each water regulating valve is connected to the proper condenser purge valve.

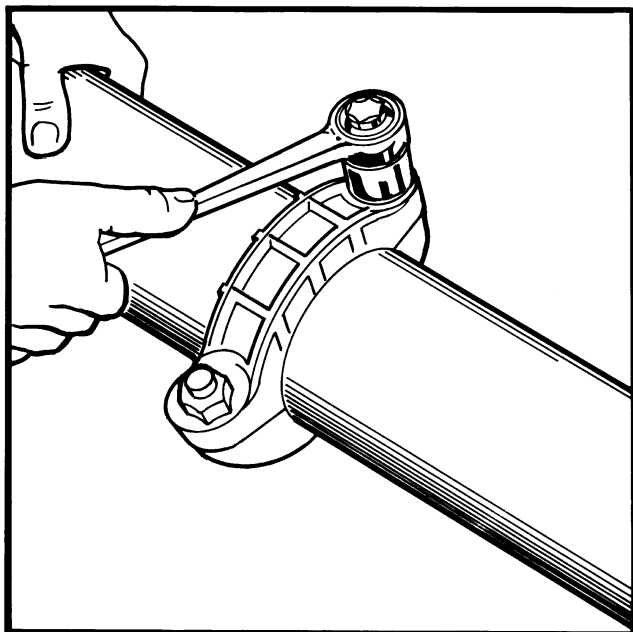

Fig. 15 — Installed Coupling Fastening Grooved Pipe Ends

Provide a means for draining the system in the winter (if not used) and for maintenance.

Accessory steel manifold packages for inlet and outlet condenser water are available for 30HK units. Each manifold is furnished in 2 sections, to be field welded as shown in Fig. 4. Manifolds should not be used where regulating valves are required because separate valves must be used on each condenser circuit.

▲ CAUTION

Retighten all condenser head bolts before filling system with water. Torque bolts to a maximum of 40 to 45 ft-lb.

Water leaving the condenser is under pressure and should not be connected directly into sewer lines. Check local codes. A 3/8-in. drain plug is located in the head at each condenser end.

Refer to Pressure Relief Devices and Discharge Line Check Valve sections on page 28, concerning piping connections for these components.

COOLER DESCRIPTION

30HK, HL Units — The cooler is a direct-expansion type with removable heads and is partitioned for multi-pass refrigerant flow. Fluid flow across the tube bundle is directed by baffles designed for minimum fluid-pressure drop. The tubes have integral internal fins for maximum heat transfer efficiency.

Viewed from unit front, the return chilled fluid enters at the left end of the cooler and leaves at the right end. The sensing bulb for the factory-supplied fluid temperature controller is in the leaving-fluid nozzle; the leaving-fluid temperature being the control point.

The cooler is insulated with a flexible, closed-cell plastic foam insulation of suitable thickness. Fluid vapor cannot penetrate the cellular structure to condense either within cells or on the cooler shell. Thus, the insulation itself is a vapor barrier. Because of the toughness of insulation, a protective sheet metal covering is not necessary.

Special modification may be necessary for brine chillers. Contact your Carrier representative for details. For calcium or sodium chloride brines, it is important that the proper inhibitors be carefully selected for protection of the copper tubes. Refer to the publications of the Calcium Institute or the Mutual Chemical Division of Allied Chemical Corporation for information on corrosion control for calcium or sodium chloride systems.

30HW Units — All 30HW units use a brazed-plate heat-exchanger type cooler. The heat exchanger is constructed essentially the same as the brazed-plate condenser used on 30HWB units. See 30HWB Condenser Description section on page 13 for more details. Similar to the condenser, the cooler can only be chemically cleaned.

COOLER PIPING — Plan cooler fluid piping for minimum number of changes in elevation, and for the fewest number of bends as possible. Install manual or automatic vent valve at high points in the line. Maintain system pressure by using a pressure tank or a combination or relief and reducing valves.

A strainer with a minimum of 20 mesh must be installed ahead of the cooler fluid inlet to prevent debris from clogging or damaging the heat exchanger.

See Carrier System Design Manual, Part 3, Piping Design, for chilled fluid piping details.

The cooler fluid inlet and outlet connections are grooved-end. On 30HW units, the fluid enters at the top connection and leaves at the bottom connection. Procedures for making the grooved-end connections are the same as for the 30HWB condensers. See 30HWB Condenser section on page 16 for more details.

Run the pump for 10 minutes, then clean the strainer before starting the unit.

A cooler flow switch must be field-installed on all units. This should be a differential pressure switch that is installed between the cooler fluid inlet and outlet. The switch should be set to open when the cooler fluid flow drops below the values shown in Table 3. Use the cooler water pressure drop curves (Fig. 16) to determine correct setting for each unit size. Use Carrier accessory flow switch, part number 30HW900003. See Table 3 for Minimum Flow rates and loop volumes.

See Step 6 — Make Electrical Connections section on page 19 for flow switch wiring details.

30HK, HL Units — The thermistor used for sensing fluid temperature is factory-installed in the cooler leaving fluid line.

30HW Units — The thermistor used for sensing the fluid temperature is inside the cooler leaving-water cavity.

Table 3 — Minimum Cooler and Condenser Flow Rates Minimum Loop Volume

UNIT SIZE	COOLER		CONDENSER*		MINIMUM COOLER LOOP VOLUME†	
	Gal./Min	L/s	Gal./Min	L/s	Gal.	L
30HK040	56.0	3.5	67	4.23	120	454.2
30HK,HL050	68.0	4.3	76	4.79	148	560.2
30HK,HL060	68.0	4.3	83	5.24	174	658.6
30HW018	22.5	1.4	22.5	1.4	44	167
30HW025	30.0	1.9	30.0	1.9	59	223
30HW028	37.5	2.4	37.5	2.4	76	288
30HW035	45.0	2.8	45.0	2.8	85	322
30HW040	57.0	3.6	57.0	3.6	113	428

LEGEND

ARI — Air Conditioning and Refrigeration Institute

N — Liters per kW

V — Gallons per ton

*30HK, HWB, HWC and HWS only.

†Minimum system fluid volumes.

NOTES:

Gallons = V x ARI capacity in tons.

Liters = N x ARI capacity in kW.

APPLICATION	V	N
Normal Air Conditioning	3	3.25
Process Type Cooling	6 to 10	6.5 to 10.8
Low Ambient Operation	6 to 10	6.5 to 10.8

COOLER PRESSURE DROP — 30HW UNITS

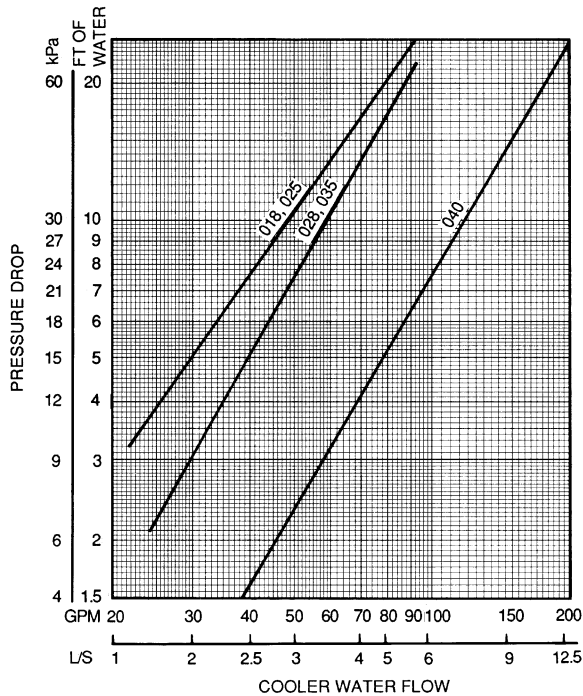

NOTE: Ft of water = 2.31 x change in psig.

COOLER PRESSURE DROP — 30HK, HL UNITS

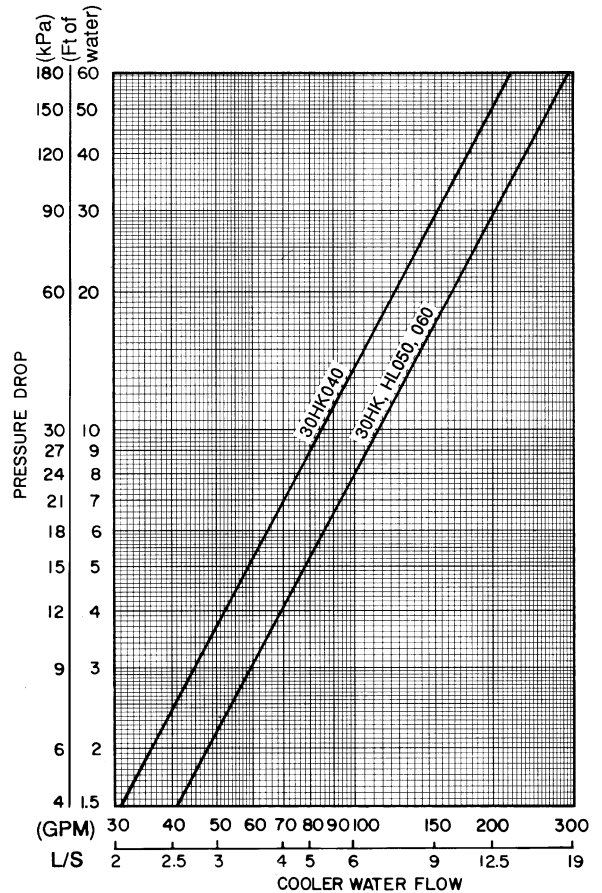
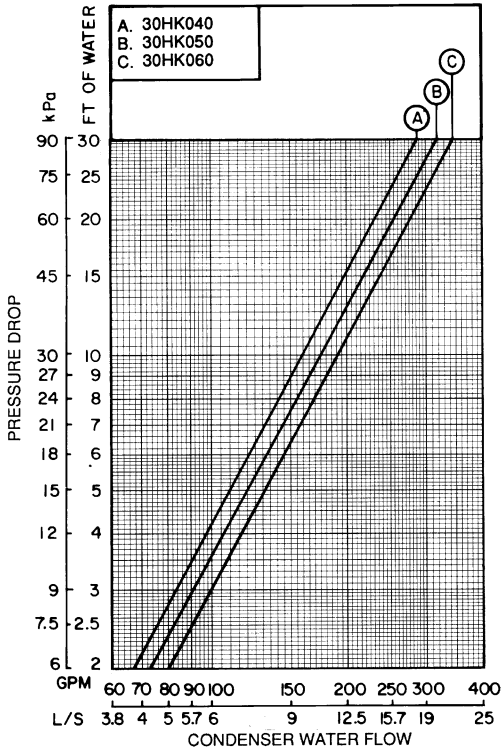
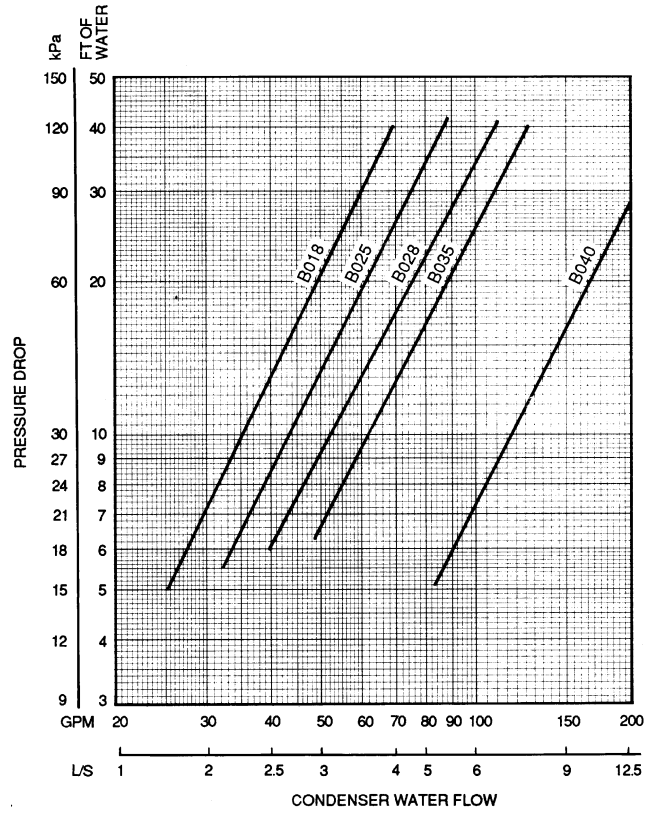

Fig. 16 — Cooler and Condenser Water Pressure Drop

CONDENSER PRESSURE DROP —
30HK UNITS



CONDENSER PRESSURE DROP —
30HWB UNITS



CONDENSER PRESSURE DROP —
30HWC AND 30HWS UNITS

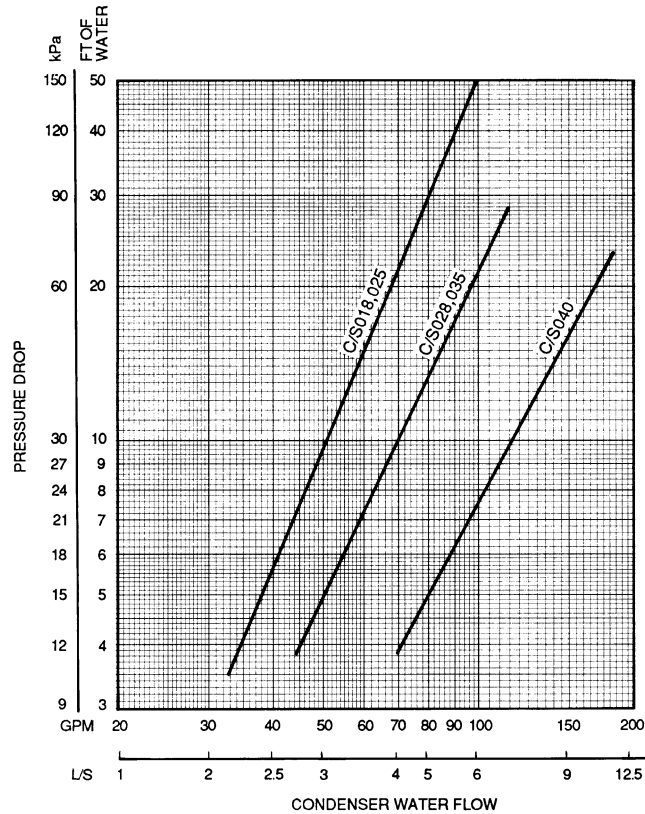

NOTE: Ft of water = 2.31 x change
in psig.

Fig. 16 — Cooler and Condenser Water Pressure Drop (cont)

Step 6 — Make Electrical Connections — All field wiring must comply with local code requirements. Electrical data for the complete unit and for the compressors is shown in Tables 4A and 4B. See Fig. 17 and 18 for field wiring connections. A field-supplied branch circuit disconnect switch that can be locked in either OPEN or OFF position **must** be installed.

30HK, HL UNITS — On all 60 Hz units, a fused (15 amp maximum), 115 v control circuit must be supplied by either a separate power source or by using a minimum 300 va transformer. On 208/230 and 460 v units, control circuit power can be supplied by accessory transformer part no. 07EA900051. Check to be sure that installation of the 115 v control power source meets all local codes.

On all 50 Hz units, a fused (15 amp maximum), 230 v control circuit must be field supplied. On 200-3-50 units, power for the control circuit can be supplied by connecting a field-supplied fuse (15 amp maximum) between TB1 and TB2 for L1 overcurrent protection. On 400-3-50 units, power for the control circuit can be supplied by connecting a field-supplied fuse (15 amp maximum) between TB1 and a neutral leg from TB2 for L1 overcurrent protection. On all units, check to be sure that installation of the 230 v control power source meets all local codes.

30HW UNITS — Control circuit power is 24 v and 115 v on all units, and is supplied by factory-installed control transformers.

ALL UNITS — Inside the control box are terminals for field power and ground (earth) wiring, as well as a terminal for a neutral wire when needed (380-3-60 and 400-3-50 units only). A ground wire must be installed with each field power supply. Compressor are wired standard from the factory for across-the-line start. As a factory-installed option, all 025-060 sizes are available wired for part-wind start (special order option on 30HK, HL unit).

Refer to Tables 4A and 4B for electrical data.

Flow Switch — A cooler flow switch is required for all units, and must be field-installed. The Carrier flow switch accessory (part number 30HW900003), is available for this purpose. Flow switch wiring terminals are located in the field wiring compartment of the control box. The flow switch should be wired between terminals TB3-1 and TB3-7 for 30HK, HL units or between terminals TB2-7 and TB2-13 for 30HW units. The factory jumper wire between these 2 terminals must be removed for proper operation of the flow switch.

Control Box, Power Section — The electrical power supply is brought in through the top left-hand side (30HK, HL) or right-hand side (30HW) of the control box (see Fig. 19 and 20). The knockout accepts up to a 3-in. (76 mm) conduit for 30HK, HL units, and a 1¾- to 2½-in. (44 to 64 mm) conduit for 30HW units. Pressure-lug connections on the terminal blocks are suitable for copper, copper-clad aluminum, or aluminum conductors.

The control box power section contains the following components:

- power terminal block
- compressor circuit breaker(s)
- compressor contactor(s)
- high-voltage transformer (30HW units only)
- control-circuit circuit breaker for 24-v circuit
- unit ON-OFF switch
- unit service light
- ground lug
- neutral terminal (380-3-60 and 400-3-50 units)
- terminal block for ground current sensing accessory

Control Box, Controls Section — The control box controls section contains the following components:

- temperature controller
- control relay(s)
- control module(s)
- low-voltage control transformer(s)
- terminal block for ground current sensing accessory

Control Box, Field Control Wiring Section — Inside this section is a 10-terminal (30HK, HL) or 14-terminal (30HW), low-voltage, field-wiring terminal strip. All low-voltage field-wiring connections are made to this terminal block. Seven ¾-in. (19 mm) knockouts are provided for field wiring in this section. Connections for chilled fluid flow switch, chilled fluid pump interlock, condenser pump interlock, remote alarm output, and ground current sensor accessory are made at this location. The remote condenser relay connections are made to a separate 4-terminal (30HK, HL) or 3-terminal (30HW) field wiring strip. See Fig. 17-20 for specific location of connections.

Unbalanced 3-Phase Supply Voltage — *Never operate a compressor where a phase imbalance in the supply voltage is greater than 2%.* Use the following formula to determine the percent voltage imbalance:

$$\% \text{ Voltage Imbalance} =$$

$$100 \times \frac{\text{max voltage deviation from average voltage}}{\text{average voltage}}$$

Example: Supply voltage is 240-3-60

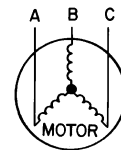

AB = 243 v
BC = 236 v
AC = 238 v

$$\begin{aligned} \text{Average Voltage} &= \frac{243 + 236 + 238}{3} \\ &= 239 \text{ v} \end{aligned}$$

Determine maximum deviation from average voltage:

(AB) 243 - 239 = 4 v
(BC) 239 - 236 = 3 v
(AC) 239 - 238 = 1 v

Maximum deviation is 4 v.

Determine percent voltage imbalance:

$$\begin{aligned} \% \text{ Voltage Imbalance} &= 100 \times \frac{4}{239} \\ &= 1.7\% \end{aligned}$$

This amount of phase imbalance is satisfactory as it is below the maximum allowable 2%.

IMPORTANT: If the supply voltage phase imbalance is more than 2%, contact your local utility company immediately.

Table 4A — Electrical Data — 30HK, HWB, HWC, HWS Fluid-Cooled Units

UNIT SIZE 30-	UNIT									COMPRESSOR (ea)				
	Volts		Voltage*		MCA	ICF		MFA	Rec Fuse	RLA	LRA		MTA	
	Nameplate (3 ph)	Hz	Min	Max		PW	XL				PW	XL	PW	XL
HK040	208/230	60	187	253	129	†	340	175	150	57	†	283	†	89
	460	60	414	518	59	†	168	80	70	26	†	142	†	40
	575	60	518	632	54	†	122	70	60	24	†	98	†	42
HK050	220	50	198	253	142	†	390	200	175	75/48**	†	342/201**	†	116/74**
	400	50	342	440	71	†	249	100	90	36/26**	†	223/142**	†	56/40**
HK060	208/230	60	187	253	161	†	503	225	200	83/57**	†	446/283**	†	89/64**
	460	60	414	518	75	†	249	110	90	39/26**	†	223/142**	†	56/40**
	575	60	518	632	73	†	188	110	90	39/24**	†	164/ 88**	†	54/37**
HWB,C,S018	208/230	60	187	253	62	—	266	110	80	49	—	266	—	89
	380	60	342	418	35	—	145	60	45	28	—	145	—	40
	460	60	414	508	28	—	120	50	35	23	—	120	—	33
	575	60	518	632	24	—	96	40	30	19	—	96	—	25
HWB,C,S025	230	50	198	253	58	—	200	100	70	46	—	200	—	63
	380/415	50	342	440	34	—	115	60	45	27	—	115	—	41
HWB,C,S028	208/230	60	187	253	72	170	283	125	90	57	170	283	88	88
	380	60	342	418	43	85	142	70	60	34	85	142	52	52
	460	60	414	508	34	85	142	60	45	27	85	142	40	42
	575	60	518	632	28	59	98	45	35	22	59	98	33	33
HWB,C,S035	230	50	198	253	67	150	250	110	80	53	150	250	80	80
	380/415	50	342	440	38	104	173	60	45	30	104	173	44	44
HWB,C,S040	208/230	60	187	253	89	268	446	150	110	71	268	446	104	104
	380	60	342	418	54	134	223	90	70	43	134	223	66	66
	460	60	414	508	44	134	223	70	60	35	134	223	50	52
	575	60	518	632	35	98	164	60	45	28	98	164	41	42
HWB,C,S048	230	50	198	253	85	205	342	150	110	68	205	342	98	98
	380/415	50	342	440	54	134	223	90	70	43	134	223	60	60
HWB,C,S055	208/230	60	187	253	102	268	446	175	125	81	268	446	120	120
	380	60	342	418	59	134	223	100	80	47	134	223	70	70
	460	60	414	508	48	134	223	80	60	38	134	223	52	57
	575	60	518	632	39	98	164	60	50	31	98	164	42	42
HWB,C,S060	230	50	198	253	94	220	366	150	125	75	220	366	112	112
	380/415	50	342	440	54	152	253	90	70	43	152	253	66	66
HWB,C,S070	208/230	60	187	253	145	414	690	250	175	116	414	690	180	180
	380	60	342	418	84	207	345	150	110	67	207	345	98	98
	460	60	414	508	69	207	345	110	90	55	207	345	78	84
	575	60	518	632	55	165	276	90	70	44	165	276	63	66
HWB,C,S080	230	50	198	253	135	327	545	225	175	108	327	545	166	166
	380/415	50	342	440	78	207	345	125	100	62	207	345	98	98

Table 4B — Electrical Data — 30HL and HWA Condenserless Units

UNIT SIZE 30-	UNIT										COMPRESSOR (ea)					
	Volts		Voltage*		MCA	ICF		MFA	Rec Fuse	RLA	LRA		MTA			
	Nameplate (3 ph)	Hz	Min	Max		PW	XL				PW	XL	PW	XL		
HL050	208/230	60	187	253	190	†	571	250	225	100/65**	†	506/315**	†	78/50**		
	460 575	60 60	414 518	518 632	84 75	† †	282 203	125 110	100 90	44/29** 38/27**	† †	253/173** 176/128**	† †	68/45** 58/42**		
HL060	200 400	50 50	198 342	253 440	187 99	† †	449 297	250 125	225 110	83 44	† †	366 253	† †	128 68		
	208/230 460 575	60 60 60	187 414 518	253 518 632	225 99 86	† † †	606 297 214	300 125 110	250 110 100	100 44 38	† † †	506 253 176	† † †	78 68 58		
HWA018	200 400	50 50	198 342	253 440	261 138	† †	616 406	350 175	300 175	116 61	† †	545 345	† †	180 95		
	208/230 380 460 575	60 60 60 60	187 342 414 518	253 418 508 632	72 40 34 28	— — — —	266 145 120 96	125 70 60 45	90 50 45 35	57 32 27 22	— — — —	266 145 120 96	— — — —	89 45 41 33		
HWA025	230 380/415	50 50	198 342	253 440	58 34	— —	200 115	100 60	70 45	46 27	— —	200 115	— —	63 41		
	208/230 380 460 575	60 60 60 60	187 342 414 518	253 418 508 632	79 47 38 30	207 104 104 72	345 173 173 120	125 80 60 50	100 60 45 40	63 37 104 24	207 104 104 72	345 173 173 120	98 52 42 33	98 52 45 37		
HWA028	230 380/415	50 50	198 342	253 440	67 38	150 104	250 173	110 60	80 45	53 30	150 104	250 173	80 44	80 44		
	208/230 380 460 575	60 60 60 60	187 342 414 518	253 418 508 632	107 60 54 42	268 134 134 98	446 223 223 164	175 100 90 70	150 80 70 50	85 48 43 33	268 134 134 98	446 223 223 164	124 70 52 42	124 70 60 52		
HWA035	230 380/415	50 50	198 342	253 440	94 54	220 152	366 253	150 90	125 70	75 43	220 152	366 253	112 66	112 66		
	208/230 380 460 575	60 60 60 60	187 342 414 518	253 418 508 632	119 67 54 44	304 152 152 106	506 253 253 176	200 110 90 70	150 80 70 60	95 53 43 35	304 152 152 106	506 253 253 176	144 80 66 50	144 80 66 52		
HWA040	230 380/415	50 50	198 342	253 440	135 78	327 207	545 345	225 125	175 100	108 62	327 207	545 345	166 98	166 98		
	208/230 380 460 575	60 60 60 60	187 342 414 518	253 418 508 632	167 95 78 63	414 207 207 165	690 345 345 276	300 150 125 110	200 125 100 80	133 76 62 50	414 207 207 165	690 345 345 276	204 106 95 73	204 106 98 76		

LEGEND FOR TABLES 4A AND 4B

- ICF** — Maximum instantaneous current flow during starting. For these single-compressor units, ICF is the compressor LRA.
 - kcmil** — Thousand circular mils
 - LRA** — Locked rotor amps. First value is for part-wind start. Larger value is the full LRA.
 - MCA** — Minimum circuit amps (for wire sizing). Complies with NEC, Section 430-24.
 - MFA** — Maximum fuse amps (225% of compressor RLA). Size down to the next standard fuse size.
 - MTA** — Must-trip amps (compressor circuit breaker).
 - NEC** — National Electrical Code (U.S.A.)
 - PW** — Part wind
 - Rec Fuse** — Recommended dual element fuse amps (150% of compressor RLA). Size up to the next standard fuse size.
 - RLA** — Rated load amps
 - XL** — Across the line
- *Supply Range — Units are suitable for use on electrical systems where voltage supplied to the unit terminals is not below or above the listed range limits.
 †Contact your local Carrier representative for part-wind details.
 **Compressor no. 1/Compressor no. 2.

NOTES FOR TABLES 4A AND 4B

1. All units have one field power terminal block.
2. Maximum incoming wire size:
 - a. 350 kcmil for unit sizes 040-060; 208/230-3-60, 230-3-50, and 400-3-50 voltages.
 - b. 2/0 for all other unit sizes; all voltages.
3. Any field modification of factory wiring must be in compliance with all applicable codes. Field-installed power wires must be rated 75 C minimum.
4. Use copper, copper-clad aluminum, or aluminum conductors for field wiring.
5. For all 30HW units, control circuit power supply is 115-v single phase for 50- and 60-Hz units. Control power is supplied by the factory-installed control transformer. Additional control circuit power is not required for 30HW units.
6. Across-the-line start is standard on all units. Part-wind start is available as a factory-installed option on 025-060 sizes (not available on 018 size; special order option on 30HK,HL units).
7. For all 30HK,HL units, control circuit MCA is 7.2, and control circuit MFA is 15. For 30HK,HL 60 Hz units, a separately-fused (15 amp maximum) 115 v, single-phase, 60 Hz, power supply or accessory transformer is required. For 30HK,HL 50 Hz units, a field-supplied, separately fused (15 amps maximum), 230 v, single-phase, 50 Hz power supply is required.



(30HK, HL, HWA, HWB, HWC 60 Hz Only)



(30HK, HL, HWA, HWB, HWC 60 Hz Only)

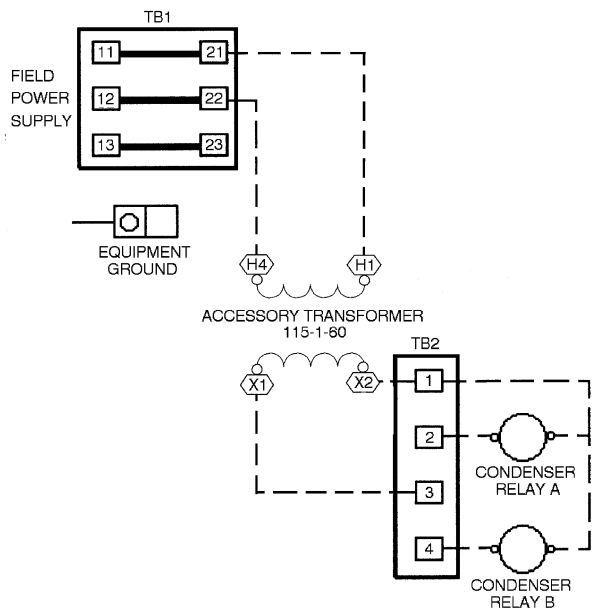

FIELD POWER WIRING, 60 Hz UNITS

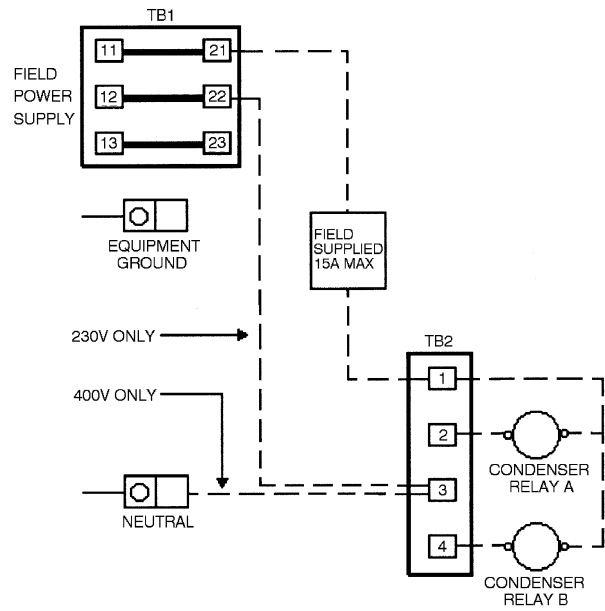

FIELD CONTROL WIRING, 50 Hz UNITS

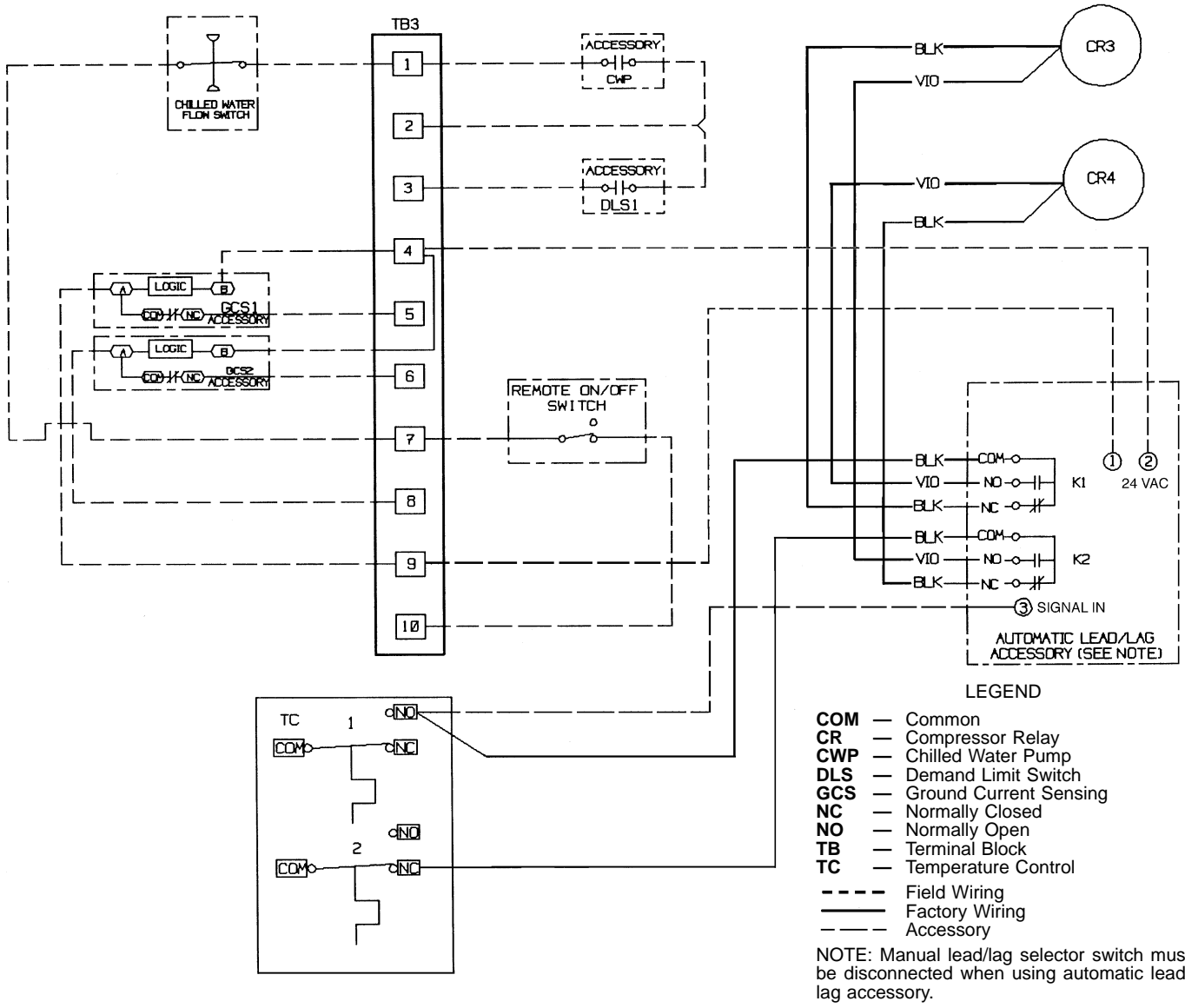

FIELD ACCESSORY WIRING

Fig. 17 — Field Wiring Diagram; 30HK, HL Units

NOTE: Factory wiring is in accordance with the National Electrical Code (U.S.A.). Any field modifications or additions must be in compliance with all applicable codes. Field installed power wires must be rated 75° C minimum.

- LEGEND**
- Alarm
 - Contactor, Compressor
 - Common
 - Equipment
 - Ground
 - Normally Closed
 - Normally Open
 - Relay
 - Terminal Block
 - Torroid, Accessory Ground Fault Interrupt
 - Field Wiring
 - Factory Wiring
- A** — Alarm
C — Contactor, Compressor
COM — Common
EQUIP — Equipment
GND — Ground
NC — Normally Closed
NO — Normally Open
R — Relay
TB — Terminal Block
TOR — Torroid, Accessory Ground Fault Interrupt

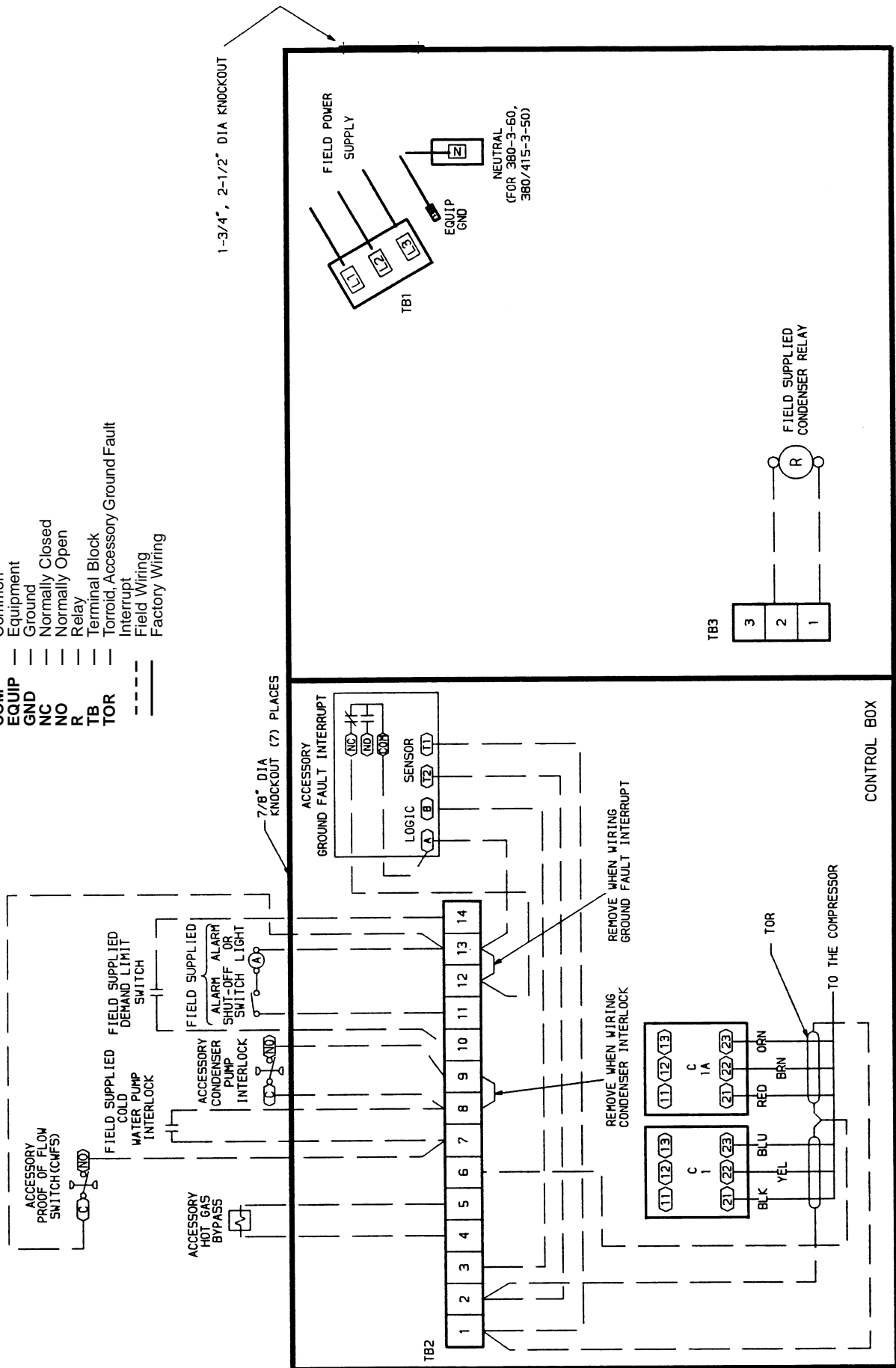
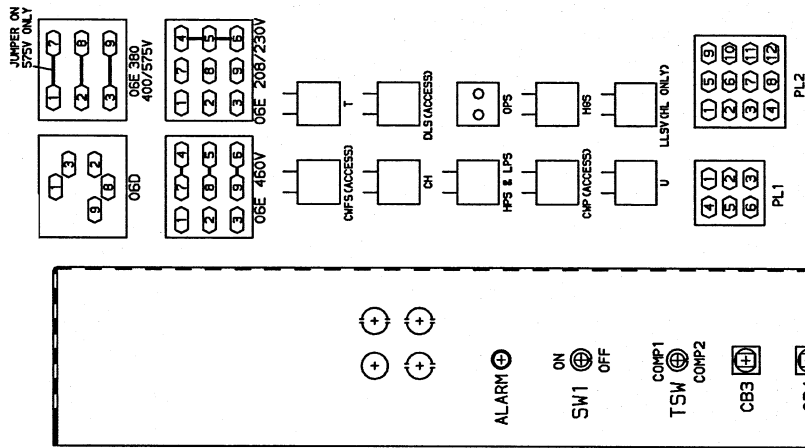
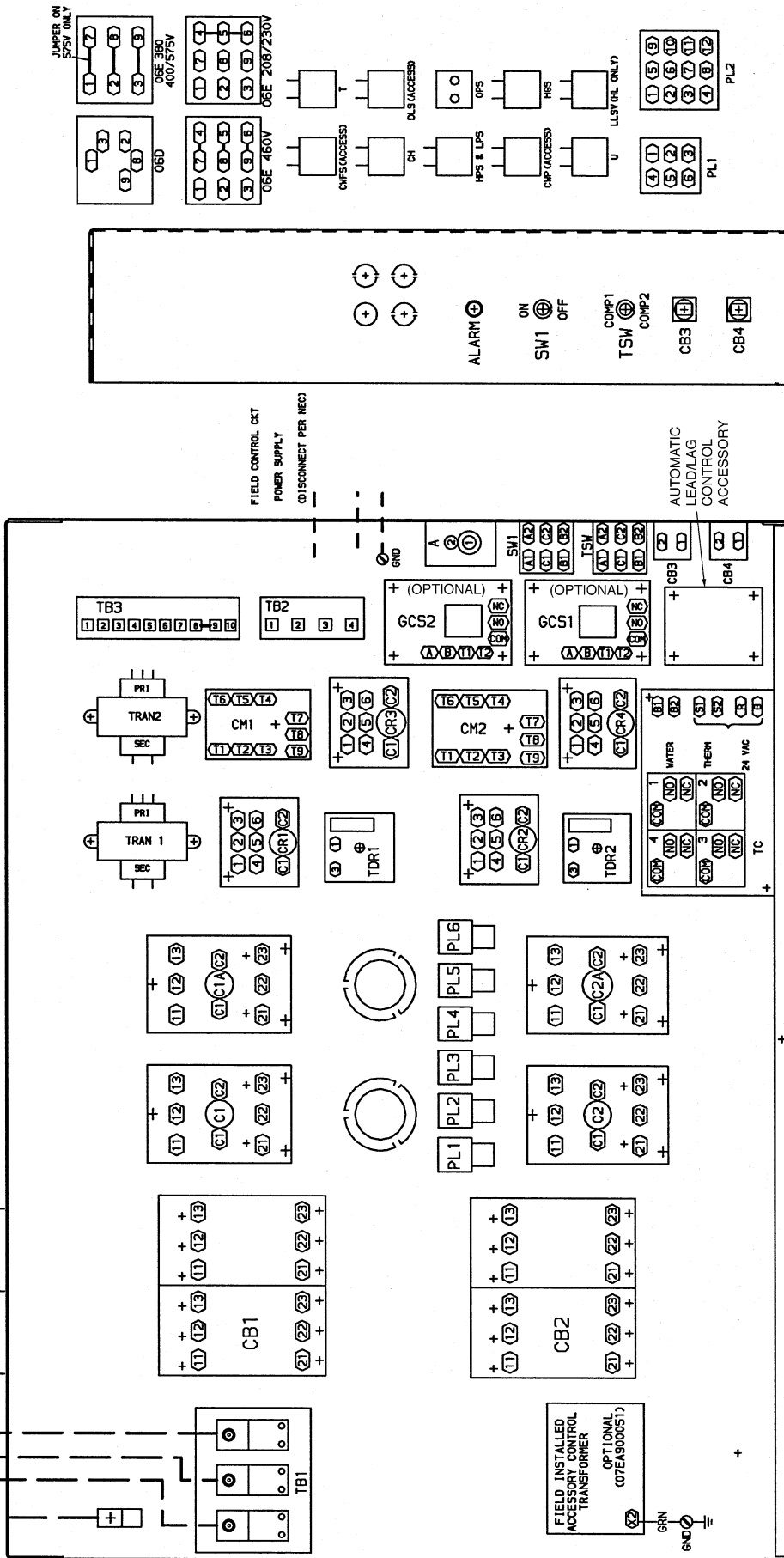

Fig. 18 — Field Wiring Diagram; 30HW Units

COMPONENT ARRANGEMENT



FIELD CONTROL CRT
POWER SUPPLY
DISCONNECT PER NEC

AUTOMATIC
LEAD/LAG
CONTROL
ACCESSORY

- LEGEND**
- Primary (Transformer)
 - Suction
 - Secondary (Transformer)
 - Switch
 - Thermistor
 - Terminal Block
 - Temperature Control
 - Time Delay Relay
 - Thermistor
 - Transformer
 - Transfer Switch
 - Unloader

- LEGEND**
- Ground Current Sensing
 - Ground
 - Hot Gas Solenoid
 - High-Pressure Switch
 - Liquid Line Solenoid Valve
 - Low-Pressure Switch
 - Normally Closed
 - National Electrical Code (U.S.A.)
 - Normally Open
 - Oil Pressure Switch
 - Plug

- LEGEND**
- Alarm
 - Contactor
 - Circuit Breaker
 - Crankcase Heater
 - Control Module
 - Common
 - Compressor
 - COMP
 - Chilled Water (Fluid) Flow Switch
 - CWFS
 - Chilled Water (Fluid) Pump
 - CWP
 - Discharge
 - Demand Limit Switch
 - DLS

Fig. 19 — 30HK, HL Control Box

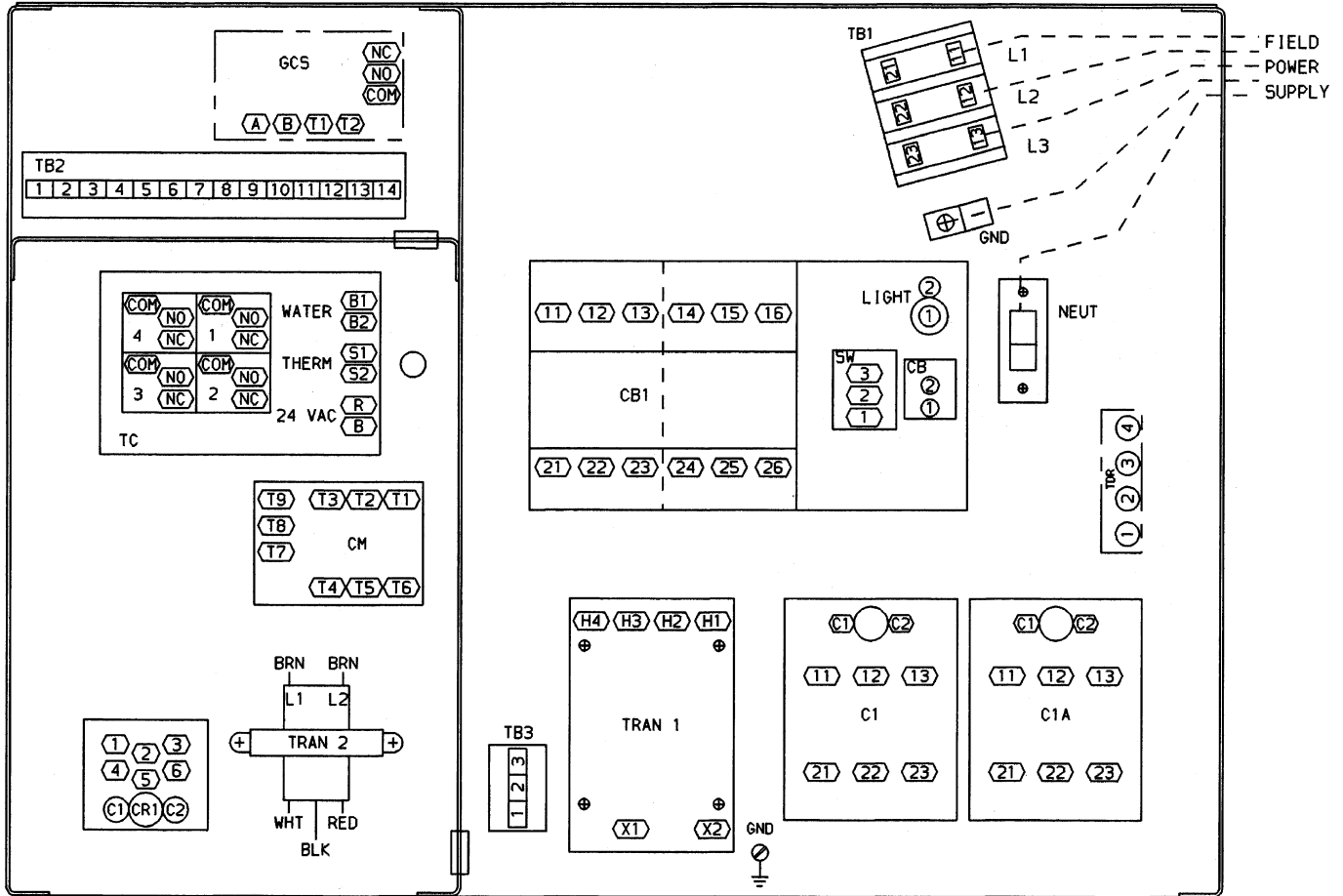

- LEGEND**
- | | | |
|-----------------------------|------------------------------------|-------------------------------|
| C — Contactor | GCS — Ground Current Sensor | SW — Switch |
| CB — Circuit Breaker | GND — Ground | TB — Terminal Block |
| CM — Control Module | NC — Normally Closed | TDR — Time Delay Relay |
| COM — Common | NEUT — Neutral | THERM — Thermistor |
| CR — Control Relay | NO — Normally Open | TRAN — Transformer |

Fig. 20 — 30HW Control Box Components Label

PRE-START-UP

IMPORTANT: Before beginning Start-Up, complete Start-Up Checklist on pages CL-1 to CL-4. This checklist assures proper start-up of a unit, and provides a record of unit condition, application requirements, system information, and operation at initial start-up.



ELECTRIC SHOCK HAZARD

Open all disconnects before servicing this equipment. There may be more than one disconnect.

Initial Check

IMPORTANT: Electrical power source must agree with unit nameplate rating. Do not start the chiller, even momentarily, until the following checks have been completed.

1. Check all auxiliary components, such as cooling tower (if used), chilled liquid and condenser water pumps, air-handling equipment, or other equipment to which the chiller supplies liquid. Consult manufacturer's instructions.
2. Be sure flow switch is properly installed and set. See instructions packaged with flow switch accessory.
3. Set the temperature controller deadband as specified in Tables 5 and 6. Set point should be at the desired cooler leaving fluid temperature. Refer to Chilled Fluid Temperature Controller section on page 29 for additional deadband setting information.
4. Backseat (open) compressor suction and discharge shut-off valves. Crack open valves (one turn in) to allow some pressure to each test gage (if installed).
5. Backseat (open) liquid line shutoff valve(s).
6. Open valve to capillaries from fluid regulating valve (when used).
7. Fill chilled fluid liquid circuit with clean water or other noncorrosive fluid to be cooled. Bleed all air out of the high points of the system. Set flow rate according to job requirements. See Table 3. If the chilled water is to be maintained at a temperature below 40 F (4.4 C), a brine of sufficient concentration must be used to prevent freeze-up at anticipated suction temperatures.
8. Open supply valve (or fill cooling tower, if used) for condenser water.
9. Check tightness of all electrical connections.

Table 5 — Typical Deadband Requirements

UNIT CAPACITY STEPS	COOLER DESIGN RANGE, F (C)		
	5.0 (2.8)	10.0 (5.6)	15.0 (8.3)
2	1.3 (0.7)	2.5 (1.4)	3.8 (2.1)
3	0.8 (0.4)	1.7 (0.9)	2.5 (1.4)
4	0.6 (0.3)	1.3 (0.7)	1.9 (1.1)

Table 6 — Deadband Setting

MIN. REQUIRED DEADBAND		DEADBAND SETTING (F)
F	C	
0.5 to 1.5	0.28 to 0.83	1.0
2.0	1.11	2.0
2.5	1.39	2.5
3.0	1.67	2.8
3.5	1.94	3.0
4.0	2.22	3.7
4.5	2.50	4.0

10. Check compressor oil charge (should be visible in oil sight glass). Refer to Check Oil Charge section on page 27.
11. Be sure the compressor crankcase heater is warm (heater should be on for 24 hours before starting the compressor). The crankcase heater must be firmly locked into the compressor crankcase.
12. Be sure the compressor is floating freely on the compressor springs (see Step 4 — Check Compressor Mounting and Connections section on page 3).
13. For 30HL and HWA units with remote condenser, check the condenser fans for correct rotation. See instructions shipped with the condenser.
14. Be sure the unit is fully charged with refrigerant (see Check Refrigerant Charge section below).
15. If unit is a brine unit, check to ensure proper brine concentration is used to prevent freezing.

Check Refrigerant Charge

⚠ CAUTION

When adding or removing refrigerant charge, circulate water through condenser and cooler at all times to prevent freezing. Freezing damage is considered abuse and is not covered by Carrier warranty.

The 30HK, HWB, HWC, and HWS units are shipped with a full refrigerant charge (see Tables 1A-2B). However, if it is necessary to add refrigerant, operate the unit for some time at full capacity and then add charge until the sight glass is clear of bubbles. For maximum liquid subcooling, liquid level should be up to condenser end (30HK, HWC, HWS units only). This usually requires additional refrigerant charge beyond the amount to clear sight glass.

The 30HL and HWA units (condenserless) are shipped with a refrigerant holding charge only. After chiller assembly is completed in the field, system must be fully charged. While the unit is running at full capacity, add refrigerant until the sight glass is clear. R-22 is the normal refrigerant.

Do not open the liquid valve or the compressor discharge valve until there is a charge in remainder of system. A *positive pressure indicates a charge in system*. With the unit operating at **full load**, check liquid line sight glass to be sure the unit is fully charged (bubbles in the sight glass indicate the unit is **not** fully charged).

If there is no refrigerant vapor pressure in the system, the entire system must be leak tested. After repairing leaks, evacuate the system before recharging. Follow approved evacuation procedures when removing refrigeration. Release remaining pressure to an approved evacuated cylinder.

The liquid charging method is recommended for complete charging or when additional charge is required.

⚠ CAUTION

Be careful not to overcharge the system. Overcharging results in higher discharge pressure with higher cooling water consumption, possible compressor damage, and higher power consumption.

LIQUID CHARGING METHOD — Add charge to the unit through the liquid line service valve. **Never charge liquid into the low-pressure side of the system.**

1. Frontseat (close) condenser liquid line shutoff valve.
2. Connect a refrigerant cylinder loosely to the charging valve connection of the liquid line shutoff valve. Purge the charging hose and tighten the connections.
3. Open the charging valve.
4. If the system has been dehydrated and is under vacuum, break the vacuum with refrigerant gas. For R-22, build up system pressure to 58 psig and 32 F (400 kPa and 0° C). Invert the refrigerant cylinder so that the liquid refrigerant will be charged.
5. a. For complete charge of 30HK, HWB, HWC, and HWS units, follow charging by weight procedure. When charge is nearly full, complete the process by observing the sight glass for clear liquid flow. *The use of sight glass charging is valid only when unit is operating at full capacity (no unloaders energized).*
 b. For complete charge of 30HL and HWA units or where refrigerant cylinder cannot be weighed, follow charging by sight glass procedure. *The use of sight glass charging is valid only when unit is operating at full capacity (no unloaders energized).*
6. a. The 30HL and HWA condenserless units are shipped with a holding charge only. After installation with the field-supplied system high side, the complete system should be charged until the sight glass is clear (with the unit running at full capacity). To achieve maximum system capacity, add additional charge equal to the difference between the condenser optimal charge and the condenser minimum charge, which can be obtained from the charge data provided in the condenser installation instructions.
 b. To ensure maximum performance of 30HWB units, raise the compressor saturated discharge temperature (SDT) to approximately 105 F (40.6 C) by throttling the condenser water intake. Add charge until there is approximately 15 to 17° F (8.3 to 9.4° C) of system subcooling (SDT minus actual temperature entering the thermostatic expansion valve).
 c. To ensure maximum performance of 30HK, HWC, and HWS units, raise the compressor saturated discharge temperature (SDT) to approximately 103 F (39.4 C) by throttling the condenser water intake. Add charge until there is approximately 8 to 10° F (4.4 to 5.6° C) for 30HK units or 12 to 14° F (6.7 to 7.8° C) for 30HWC, HWS units of system subcooling (SDT minus actual temperature entering the thermostatic expansion valve).

Check Oil Charge — The compressor(s) is factory-charged with oil. If oil is visible in the compressor sight glass(es), check the unit for operating readiness as described in Initial Check section (page 25), then start the unit. Observe oil level and add oil, if required, to bring the oil level in the compressor crankcase(s) to between 1/8 and 3/8 of the sight glass(es) during steady operation.

TO ADD OIL

1. Close the suction shutoff valve and pump the compressor crankcase down to between zero and 2 psig (zero to 13.8 kPa) (the low-pressure switch must be jumpered). Wait a few minutes and repeat as needed until the pressure remains between zero and 2 psig (zero to 13.8 kPa).
2. Close the discharge shutoff valve.
3. Remove the oil-fill plug above the compressor sight glass, add oil through the plug hole, and replace the plug.
4. After opening the suction and discharge service valves, remove low-pressure switch jumper, run the compressor for about 20 minutes, and check the oil level.

Use only Carrier-approved compressor oil:

Petroleum Specialties, Inc.Cryol 150*
 Texaco, Inc.Capella WF-32
 Witco Chemical Co.Suniso 3GS
 *Factory charge.

Do not reuse drained oil, and do not use any oil that has been exposed to the atmosphere.

TO REMOVE OIL

⚠ CAUTION

The crankcase will be under slight pressure. Be careful not to lose the entire oil charge. Gloves and eye protection must be worn.

Pump down the compressor to between zero and 2 psig (zero to 13.8 kPa). Loosen the oil drain valve located in the compressor base to allow the oil to seep out past plug threads. Be careful not to remove plug; the entire oil charge may be lost. Small amounts of oil can be removed through oil pump discharge connection.

START-UP AND OPERATION

Operation Checks — Start-up should be performed only under supervision of an experienced refrigeration technician. Refer to Start-Up Checklist on pages CL-1 to CL-4. Remove and save the checklist for future reference.

1. Crankcase heater must be energized for at least 24 hours before the chiller is started.
2. Open all system valves that may have been closed during or after charging.
3. Check air-handling equipment, chilled water (fluid) and condenser pumps, and any other equipment connected to the chiller.
4. Start the unit by moving the ON-OFF switch to the ON position.
5. Check all controls for proper operation. Follow Start-Up Checklist procedures in these instructions.
6. Adjust the water regulating valve (where used) to obtain the most economical head pressure (based on the relative cost of water and electricity). Head pressure is normally 200 to 230 psig (1379 to 1586 kPa) for 30HK,HL units, and 195 to 226 psig (1344 to 1558 kPa) for 30HW units when using R-22 refrigerant.
7. Check the cooler leaving chilled water temperature to see that it remains well above 32 F (0° C), or the brine freezing point if the unit is a medium temperature brine unit.

8. Recheck compressor oil level (see Check Oil Charge section on this page). Add or remove oil to achieve the level required during steady operation.

Operating Limitations

⚠ WARNING

Do not operate with cooler leaving chiller water (fluid) temperature (LCWT) below 40 F (4.5 C) for the standard units, or below 15 F (-9.4 C) for units factory built for medium temperature brine.

HIGH COOLER LEAVING CHILLED WATER (FLUID) TEMPERATURES (LCWT) — During start-up with cooler LCWT above approximately 60 F (16 C), the unit expansion valve will limit suction pressure to approximately 90 psig (620 kPa) to avoid overloading the compressor.

LOW COOLER LCWT — For standard units, the LCWT must be no lower than 40 F (4.5 C). If the unit is the factory-installed optional medium temperature brine unit, the cooler LCWT can go down to 15 F (-9.4 C).

MAIN POWER SUPPLY — Minimum and maximum acceptable supply voltages are listed in Tables 4A and 4B.

Unbalanced 3-Phase Supply Voltage — *Never operate a motor where a phase imbalance between phases is greater than 2%. To determine percent voltage imbalance, see Unbalanced 3-Phase Supply Voltage section on page 19.*

Check Refrigerant Feed Components

THERMOSTATIC EXPANSION VALVE (TXV) — The TXV controls the flow of liquid refrigerant to the cooler by maintaining constant superheat of vapor leaving the cooler. There is one valve per refrigerant circuit. The valve(s) is activated by a temperature-sensing bulb(s) strapped to the suction line(s).

The valve(s) is factory-set to maintain between 8° and 10° F (4.4° and 5.6° C) of superheat leaving the cooler. Check the superheat during operation after conditions have stabilized. If necessary, adjust the superheat to prevent refrigerant floodback to the compressor.

FILTER DRIER — The function of the filter drier is to maintain a clean, dry system. The moisture indicator (described below) indicates any need to change the filter drier. The filter drier is a sealed-type drier. When the drier needs to be changed, the entire filter drier must be replaced.

NOTE: The 30HK, HL units have 2 filter driers; one per circuit.

MOISTURE-LIQUID INDICATOR — The indicator is located immediately ahead of the TXV to provide an indication of the refrigerant moisture content. It also provides a sight glass for refrigerant liquid. Clear flow of liquid refrigerant (*at full unit loading*) indicates sufficient charge in the system. Bubbles in the sight glass (*at full unit loading*) indicate an undercharged system or the presence of noncondensables. Moisture in the system, measured in parts per million (ppm), changes the color of the indicator as follows:

- Blue** (safe) — Moisture is below 45 ppm
- Light Violet** (caution) — 45 to 180 ppm
- Pink** (wet) — above 180 ppm

The unit must be in operation at least 12 hours before the moisture indicator gives an accurate reading, and must be in contact with *liquid* refrigerant. At the first sign of moisture in the system, change the corresponding filter drier.

NOTE: The 30HK, HL units have 2 indicators; one per circuit.

LIQUID LINE SERVICE VALVE — This valve provides a refrigerant charging port and, in combination with the compressor discharge service valve(s), allows the refrigerant to be pumped into the high side of the system.

DISCHARGE LINE CHECK VALVE — On all 30HL, HWA units, a factory-supplied check valve is shipped with the unit (two valves are provided for 30HL units). The check valve(s) should be installed in the discharge line(s) downstream from, but close to, the compressor muffler. Install the valve in any position except bonnet down.

The check valve(s) prevents backwards-migration of refrigerant from the condenser(s) to the compressor(s) and cooler during the compressor off cycle.

HOT GAS BYPASS VALVE — On units equipped with the factory-installed capacity reduction option (30HW only), a hot gas bypass valve is located between the discharge line and the cooler entering-refrigerant line. A solenoid valve is installed in the equalizer line of the hot gas valve to allow the temperature control to cycle the hot gas bypass function.

The amount of capacity reduction achieved by the hot gas bypass valve may be altered by adjusting the spring tension of the hot gas bypass valve. The total unit capacity should not be reduced below 10% of the nominal rating.

LIQUID LINE SOLENOID VALVE (30HL ONLY) — The solenoid valve closes when its circuit is inoperative, either from capacity control or from any safety trip.

PRESSURE RELIEF DEVICES — All 30HK, 30HL, and 30HW units are equipped with a compressor pressure relief valve located on the crankcase of the 06E compressor units (except for the 30HW018 units which have a compressor displacement less than 50 cfm). The pressure relief valve opens at 450 psig (3103 kPa).

The 30HK,HWC, and HWS units are also equipped with a high-side refrigerant pressure relief valve on the shell and tube condenser. The valve is set to open at the working pressure of the condenser, as shown in Table 7.

The 30HWB does not have a condenser pressure relief valve, because the brazed-plate condenser is not considered a pressure vessel, as defined in ANSI/ASHRAE 15 (American National Standards Institute/American Society of Heating, Refrigerating, and Air Conditioning Engineers) safety code requirements.

For 30HL and HWA condenserless units, pressure relief devices designed to relieve at 450 psig (3103 kPa), must be field-supplied and installed in the discharge line piping after the muffler in accordance with ANSI/ASHRAE 15 safety code requirements. Additional pressure relief valves, properly selected, must be field-supplied and installed to protect high side equipment and may be required by applicable codes.

Most codes require that a relief valve be vented directly to the outdoors. *The vent line must not be smaller than the relief valve outlet. The condenser relief valves have a ³/₈-in. SAE (Society of Automotive Engineers, U.S.A.) flare connection. The compressor relief valves have a ³/₈-in. SAE Flare connection.* Consult ANSI/ASHRAE 15 for detailed information concerning layout and sizing of relief vent lines.

All units have a factory-installed fusible plug in the suction line which relieves on a temperature rise at 170 F (77 C) and one in the liquid line which relieves at 210 F (99 C).

Table 7 — Pressure Relief Valve Settings

UNIT	PRESSURE RELIEF VALVE SETTINGS	
	Psig	kPa
30HK	385	2655
30HWC	365	2517
30HWS	335	2310

Compressor and Unit Protective Devices

CIRCUIT BREAKER — There is a single circuit breaker per compressor in each unit. The circuit breaker(s) protects the compressor(s) against overloading, locked rotor conditions, and primary single phasing. If the circuit breaker(s) trips, determine the cause and correct it before resetting the breaker(s).

COMPRESSOR INTERNAL THERMAL PROTECTION — On the 30HW018 units, there is a sensor imbedded in the compressor windings to detect an overtemperature condition.

The thermostat opens and shuts off the compressor if the discharge gas temperature exceeds 295 ± 5° F (146 ± 2.8° C). The thermostat will reset when the temperature drops to approximately 250 F (121 C). However, the control module will keep the unit locked off until control power is manually cycled off, then back on.

NOTE: Compressor overtemperature protection for 30HK, HL units is accomplished by high and low pressure switches and circuit breakers which are external to the compressors.

CRANKCASE HEATER

▲ CAUTION

Never open or disconnect any switch that energizes the crankcase heater, unless the unit is being serviced or will be shut down for an extended period. After service or shutdown, energize the crankcase heater for 24 hours before starting the compressor.

IMPORTANT: The crankcase heater is located in the bottom corner of the compressor and held in place by a bracket. The heater must be tight to prevent it from backing out of the heater well. The heater eventually burns out if exposed to the air for an extended period.

The heater in each compressor prevents absorption of liquid refrigerant by the compressor oil when the compressor is not operating. The heater is wired into the normally closed contacts of the compressor control relay so that it energizes only when the compressor is not operating. The heater is 125 w, 115 v on all 60 Hz units; 230 v on 50 Hz 30HK, HL units; and 115 v on 50 Hz 30HW units.

OIL PRESSURE SAFETY SWITCH (OPS) — One OPS per compressor is standard on all 30HL and HWA units, and on all units equipped with the medium temperature brine option. One is located in each compressor terminal box with capillaries to the crankcase and oil pump. The switch is also offered as an accessory (part number 30HW900006) for standard 30HK, HWB, HWC, and HWS units. When used, the OPS is monitored by the unit control module. If at any time after the compressor is started, the OPS is open for more than 2 minutes, the compressor shuts down and is locked off until control power is manually cycled to OFF, then back to the ON position. The OPS cuts out at 5 ± 1 psig (34.5 ± 6.9 kPa), and has a maximum cut-in of 9.5 psig (65.5 kPa).

Check Unit Safeties

CONTROL MODULE — The unit control module is located in the control section of the control box. See Fig. 19 and 20. It performs several functions. The control module has a built-in compressor anti-short-cycle timer which will not allow a compressor to restart until 5 minutes have elapsed since the previous shutdown.

On 30HL and HWA units (and 30HK, HWB, HWC, and HWS units equipped with the oil pressure safety switch [OPS] accessory), the compressor oil pressure and low-pressure switch(es) (LPS) are monitored through the control module. The unit is allowed to remain operational as long as the OPS and/or LPS have not been open for more than 2 minutes after a compressor has started. After start-up, if the OPS and/or LPS are open for more than 2 minutes, the control module shuts down the compressor and places the unit in a lockout condition. The control module activates the fault indication circuit, and the unit service lamp is illuminated. The unit cannot be restarted until control power is manually cycled to OFF, then to ON.

The control module also monitors the high-pressure switch(es) and compressor internal thermal protection (30HW). If at any time one or both of these switches opens, the control module shuts down the compressor and places the unit in a lockout condition. The control module activates the fault indication circuit, and the unit service lamp is illuminated. The unit cannot be restarted until control power is manually cycled to OFF, then to ON.

If the unit shuts down on an automatic reset switch, such as the temperature controller, the compressor will be allowed to restart when the switch closes and the control module anti-short-cycle time has elapsed.

For Servicing Only — To speed up the 5-minute anti-short cycle, a jumper may be placed between terminals T1 and T6 of the control module.

This jumper must be removed after servicing is complete. Failure to remove this jumper is considered abusive treatment and will void the Carrier warranty.

HIGH-PRESSURE SWITCH — A high-pressure switch is provided to protect each compressor and refrigeration system from unsafe high pressure conditions. See Table 8 for high-pressure switch settings.

The high-pressure switch is mounted in the discharge side of each compressor. A snubber is provided between the compressor discharge manifold and the high-pressure switch to prevent pressure pulsations from damaging the switch.

If an unsafe, high-pressure condition should exist, the switch opens and shuts off the affected compressor. The unit control module prevents the unit from restarting. The unit will not restart until control power is manually cycled off, then on.

To check operation of the switch, slowly close the compressor discharge shutoff valve until the compressor shuts down. The switch should open at the pressure corresponding to the appropriate switch setting as shown in Table 8.

Table 8 — Factory Settings, High-Pressure Switch (Fixed)

UNIT 30	CUTOUT		CUT-IN	
	Psig	kPa	Psig	kPa
HK, HWS	280 ± 10	1931 ± 69	180 ± 20	1241 ± 138
HL, HWB, HWC	375 ± 10	2585 ± 69	275 ± 20	1896 ± 138
HWA	395 ± 10	2723 ± 69	298 ± 20	2054 ± 138

Reopen the compressor discharge shutoff valve, and cycle the unit ON-OFF switch to OFF, then ON. The unit should restart after the compressor anti-short-cycle delay, built into the unit control module, expires.

LOW-PRESSURE SWITCH — A low-pressure switch is provided to protect each compressor and system from a loss of refrigerant. The low-pressure switch(es) also provides freeze protection for the cooler. The low-pressure switch(es) is non-adjustable. See Table 9 for low-pressure switch settings. One switch is used for standard units, and a different switch is used for units with the brine option.

Table 9 — Factory Settings, Low-Pressure Switch (Fixed)

UNIT TYPE	CUTOUT		CUT-IN	
	Psig	kPa	Psig	kPa
STANDARD	42 ± 3	290 ± 21	57 ± 5	393 ± 34
BRINE	27 ± 3	186 ± 21	44 ± 5	303 ± 34

To check operation of the low-pressure switch, slowly close the suction service valve and allow the affected compressor to pump down. The compressor should cut out when the suction pressure falls below the low-pressure switch cutout setting. Open the suction service valve. The compressor should restart after the low-pressure switch closes, and the compressor anti-short-cycle delay expires.

CHILLED FLUID TEMPERATURE CONTROLLER — All units are equipped with a temperature controller (see Fig. 21) which is capable of controlling up to 4 steps of capacity. A thermistor installed inside the cooler supplies the input to the controller. The temperature controller can operate a system with cooling ranges (entering cooler fluid temperature minus leaving cooler fluid temperature) of 5° to 15° F (2.8° to 8.3° C), and with a range of set points from 40 to 60 F (4.4 to 15.5 C) for standard units, and 15 to 39 F (-9.4 to 3.9 C) for units with the medium temperature brine option.

The set point of the temperature controller should be adjusted to the desired leaving cooler fluid temperature, and verified by using a thermometer placed in the leaving-cooler piping. The amount of deadband around the set point value is adjusted through the use of the deadband adjustment knob on the temperature controller. See Tables 5 and 6 for the correct setting of the deadband.

The unit should then control the average leaving-fluid temperature to this setting. If the leaving-fluid temperature does not correspond to the desired set point, slightly readjust the controller set point knob until the desired leaving-fluid temperature is obtained. The temperature controller has an adjustable 30-second (HI position) to 3-minute (LO position) sample rate knob. The sample rate knob should always be set at LO position (fully clockwise) for 30HK, HL units, and at HI position (fully counterclockwise) for 30HW units.

CAUTION
Do not force the knob dials past the stops. This could cause loss of control point and damage to the controller.

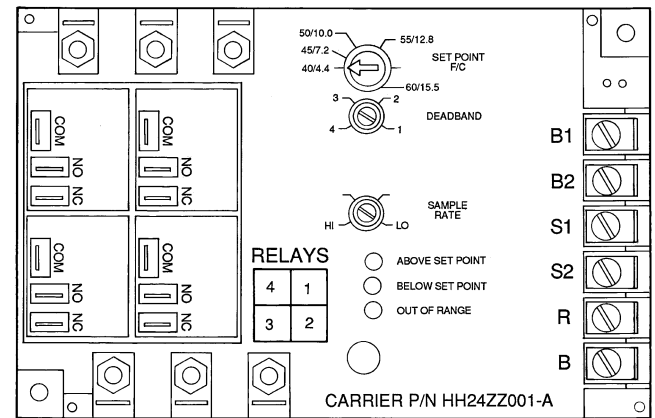

LEGEND
COM — Common
NC — Normally Closed
NO — Normally Open

Fig. 21 — Temperature Controller

Once the compressor is shut off, the control system prevents the compressor from restarting within 5 minutes of when it was last shut down. Once this period has elapsed and the leaving fluid temperature rises above the set point, the compressor will start within 5 seconds.

If the unit is equipped with field-installed hot gas bypass, the hot gas bypass valve opens only when stage 1 is active.

If the unit trips out on high pressure, low pressure, ground current (accessory), or low oil pressure, the control module locks the unit off and must be manually reset (turn the ON-OFF switch to OFF and then back to ON). If the unit trips out on low fluid temperature, chilled fluid flow switch, or chilled fluid pump switch, it restarts automatically when the condition is corrected.

30HW UNITS — Close the compressor circuit breaker and move ON-OFF switch to the ON position. The switch should light up. In approximately 3 seconds, the compressor starts unloading. For 2 minutes the low-pressure switch is bypassed and the unloaders are energized (compressor unloads when compressor unloader solenoid is energized). At end of 2-minute bypass period, the low-pressure switch activates the control circuit and the temperature controller regulates the capacity steps based on leaving cooler fluid temperature, set point and deadband settings on the temperature controller.

If system load drops to the point where the unit is fully unloaded and the fluid temperature is below the lower deadband limit, the compressor shuts off and is not able to restart until the 5-minute anti-short cycle has expired. If during normal operation, the fluid temperature rises above the upper deadband limit, the temperature controller adds a step of capacity (assuming a step is left to be added).

On condenserless units (30HWA), or on fluid-cooled units (30HWB,C, and S) equipped with the accessory oil safety switch, the control module provides a 2-minute bypass of the oil safety switch.

If the unit is equipped with hot gas bypass option, the hot gas bypass valve closes before unloaders are deactivated.

If the unit trips out on high pressure, ground current (accessory), or low oil pressure, the control module locks the unit off and must be manually reset (by turning the ON-OFF switch to OFF, then back to ON). If the unit trips out on low pressure, low fluid temperature, the chilled fluid flow switch, or the chilled fluid pump switch, it restarts automatically when the condition is corrected.

Table 10 — Capacity Control Steps — 30HK, HL Standard Units

UNIT	CONTROL STEPS	TRANSFER SWITCH COMPRESSOR NO. 1 POSITION*				TRANSFER SWITCH COMPRESSOR NO. 2 POSITION*			
		% Disp.	Operating Cylinder			% Disp.	Operating Cylinder		
			Total	Ckt 1	Ckt 2		Total	Ckt 1	Ckt 2
30HK040	1	25	2	2	—	25	2	—	2
	2	50	4	2	2	50	4	2	2
	3	75	6	4	2	75	6	2	4
	4	100	8	4	4	100	8	4	4
30HK,HL050	1	40	4	4	—	20	2	—	2
	2	60	6	4	2	60	6	4	2
	3	80	8	6	2	80	8	4	4
	4	100	10	6	4	100	10	6	4
30HK,HL060	1	33	4	4	—	33	4	—	4
	2	66	8	4	4	66	8	4	4
	3	88	10	6	4	88	10	4	6
	4	100	12	6	6	100	12	6	6

LEGEND

Ckt — Circuit
Disp. — Displacement

*Manually operated.

NOTE: Circuits are designated from left to right when viewed from front of unit.

**Table 11 — Capacity Control Steps —
30HW Standard Units**

UNIT 30HW	CAPACITY CONTROL STEPS*	CAPACITY %	OPERATING CYLINDERS
018	1	33.3	2
	2	66.7	4
	3	100.0	6
025	1	50.0	2
	2	100.0	4
028	1	33.3	2
	2	66.7	4
	3	100.0	6
035	1	33.3	2
	2	66.7	4
	3	100.0	6
040	1	33.3	2
	2	66.7	4
	3	100.0	6

*Factory-installed hot gas bypass option adds an additional capacity step to that shown in this table.

SERVICE



ELECTRIC SHOCK HAZARD

To avoid the possibility of electrical shock, turn off all power to unit before servicing.

⚠ CAUTION

Do not attempt to bypass, short-out, or modify the control circuit or electronic boards in any way to correct a problem. This could result in component failures or a hazardous operating condition.

Compressor Replacement — If a replacement 6-cylinder compressor has a center-bank cylinder head with discharge valve pad facing the pump end, remove head and install reverse flange head from original compressor (discharge valve pad toward the motor end). *Center-bank cylinder head cannot be rotated 180 degrees.*

Be sure all the hardware from the old compressor is removed and installed on the new compressor, including the high-pressure switch snubber, the discharge gas thermostat (30HW025-040), the oil pressure safety switch (if equipped), and the low-pressure switch.

The compressor can be removed from either the front or the sides of the unit, depending on where clearance space was allowed during unit installation. The compressor and mounting hardware are mounted on a plate which is screwed down to the unit basepan. Remove the 4 screws holding the plate to the basepan and the plate should easily slide out of the unit. Mount the replacement compressor to the plate, slide the plate back into the unit and secure with the 4 screws.

Circuit Breaker(s) — The breaker(s) provides 3-leg overload protection. Do not bypass connections or increase the size of the circuit breaker(s) to correct trouble. Determine the cause of the trouble and correct it before resetting the breaker(s). A tripped breaker must be manually reset by moving the circuit breaker handle to OFF, then ON position. See Tables 4A and 4B for must-trip amps (MTA).

NOTE: One circuit breaker is provided per compressor.

Brazed-Plate Cooler and Condenser Heat Exchanger Replacement

— Brazed-plate heat exchangers cannot be repaired if they develop a leak. If a leak (refrigerant or water) develops, the heat exchanger **must** be replaced. To replace a brazed plate heat exchanger:

1. Disconnect the liquid-in and liquid-out connections at the heat exchanger.
2. Check that the replacement heat exchanger is the same as the original heat exchanger. For the condensers, compare part numbers on the heat exchangers. For the coolers, insulation covers the manufacturer's part number. Make sure the depths of the replacement and original cooler heat exchangers are the same.
3. Reclaim the refrigerant from the system, and unsolder the refrigerant-in and refrigerant-out connections.
4. Remove the four 1/2-in. nuts holding the heat exchanger to the brackets. Save the nuts.
5. Install the replacement heat exchanger in the unit and attach to the bracket using the four 1/2-in. nuts removed in Step 4.
6. *Carefully* braze the refrigerant lines to the connections on the heat exchanger. Lines should be soldered using silver as the soldering material with a minimum of 45% silver. Keep the temperature below 1472 F (800 C) under normal soldering conditions (no vacuum) to prevent the copper solder of the brazed plate heat exchanger from changing its structure. Failure to do so can result in internal or external leakage at the connections which cannot be repaired.
7. Reconnect the water/brine lines.
8. Dehydrate and recharge the unit. Check for leaks.

Brazed-Plate Cooler and Condenser Heat Exchanger Cleaning

— Brazed-plate heat exchangers must be cleaned chemically. A professional cleaning service skilled in chemical cleaning should be used. Use a weak acid (5% phosphoric acid, or if the heat exchanger is cleaned frequently, 5% oxalic acid). Pump the cleaning solution through the exchanger, preferably in a backflush mode. After cleaning, rinse with large amounts of fresh water to dispose of all the acid. Cleaning materials must be disposed of properly.

The mesh screens in front of the water/brine inlets of the heat exchangers should be cleaned periodically, depending on condition of the chiller water/brine.

Shell-and-Tube Condenser Cleaning — The shell-and-tube condenser tubes can be cleaned either mechanically or chemically. To clean them chemically, follow the procedure described in Brazed-Plate Cooler and Condenser Heat Exchanger Cleaning section above.

To clean the condenser tubes manually:

1. Order tubing brushes (Carrier part no. KC21AH105).
2. Close the valves on the condenser and relieve condenser water pressure. **BE SURE TO PROVIDE DRAINAGE TO PREVENT WATER DAMAGE.**
3. Remove the condenser heads and brush the tubes clean, removing scale and other deposits.
4. Inspect the head gaskets and replace if necessary.
5. Clean all gasket surfaces prior to reassembly.
6. Replace the water heads and torque the head bolts to 90 ft-lb (122 N-m). Allow the gaskets to set overnight and re-torque the bolts to ensure proper sealing.

Thermistor — The resistance at various temperatures for the thermistor are given in Tables 12A and 12B.

THERMISTOR REPLACEMENT, 30HK, HL UNITS

⚠ CAUTION

Thermistors are installed directly in fluid circuit. Drain fluid before removing.

Proceed as follows (see Fig. 22):

1. Remove and discard original thermistor and coupling.

IMPORTANT: Do not disassemble new coupling. Install as received.

2. Apply pipe sealant to 1/4-in. NPT threads on replacement coupling and install in place of original. Do not use a packing nut to tighten coupling. This damages the ferrules (see Fig. 22).

3. Insert thermistor T1 into coupling body to its full depth. Tighten packing nut finger tight to position ferrules, then tighten 1/4 turns more using a back-up wrench. Ferrules are not attached to the sensor, which can be withdrawn from coupling for service.

THERMISTOR REPLACEMENT, 30HW UNITS — To replace the thermistor, follow these steps:

1. Disconnect the existing thermistor from the S1 and S2 terminals of the temperature controller (located in the control section of the control box).
2. Remove the thermistor from the well in the cooler leaving fluid cavity.
3. Insert the replacement thermistor into the thermistor well.
4. Run thermistor wires into the control box and connect to the S1 and S2 terminals of the temperature controller.

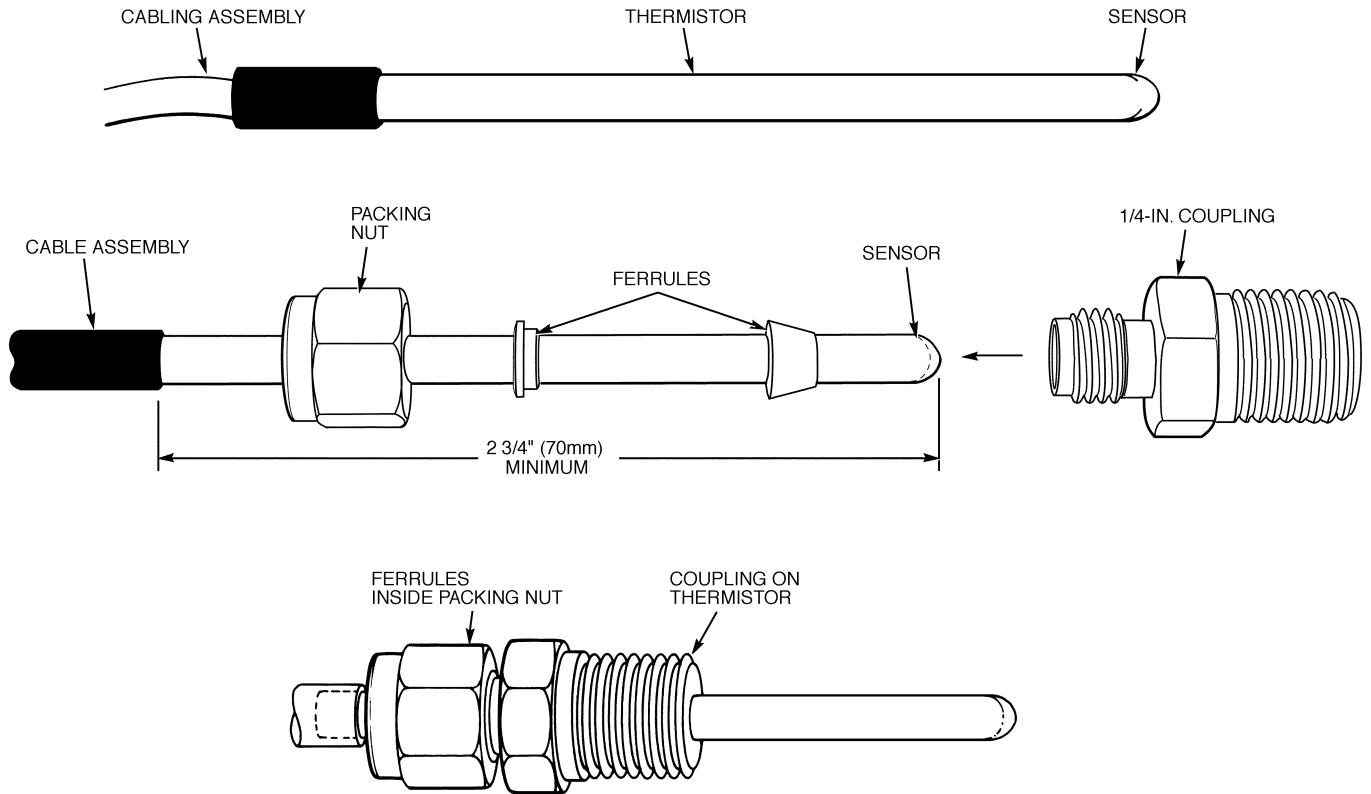

Fig. 22 — Thermistor

Table 12A — Sensor Temperature (F) vs Resistance

TEMPERATURE (F)	RESISTANCE (OHMS)	TEMPERATURE (F)	RESISTANCE (OHMS)	TEMPERATURE (F)	RESISTANCE (OHMS)
-25	98,010	63	7,091	151	1,007
-24	94,707	64	6,911	152	986
-23	91,522	65	6,735	153	965
-22	88,449	66	6,564	154	945
-21	85,485	67	6,399	155	925
-20	82,627	68	6,237	156	906
-19	79,871	69	6,081	157	887
-18	77,212	70	5,929	158	868
-17	74,648	71	5,781	159	850
-16	72,175	72	5,637	160	832
-15	69,790	73	5,497	161	815
-14	67,490	74	5,361	162	798
-13	65,272	75	5,229	163	782
-12	63,133	76	5,101	164	765
-11	61,070	77	4,976	165	749
-10	59,081	78	4,855	166	734
- 9	57,162	79	4,737	167	719
- 8	55,311	80	4,622	168	705
- 7	53,526	81	4,511	169	690
- 6	51,804	82	4,403	170	677
- 5	50,143	83	4,298	171	663
- 4	48,541	84	4,195	172	650
- 3	46,996	85	4,096	173	638
- 2	45,505	86	4,000	174	626
- 1	44,066	87	3,906	175	614
0	42,678	88	3,814	176	602
1	41,339	89	3,726	177	591
2	40,047	90	3,640	178	581
3	38,800	91	3,556	179	570
4	37,596	92	3,474	180	560
5	36,435	93	3,395	181	551
6	35,313	94	3,318	182	542
7	34,231	95	3,243	183	533
8	33,185	96	3,170	184	524
9	32,176	97	3,099	185	516
10	31,201	98	3,031	186	508
11	30,260	99	2,964	187	501
12	29,351	100	2,898	188	494
13	28,472	101	2,835	189	487
14	27,624	102	2,773	190	480
15	26,804	103	2,713	191	473
16	26,011	104	2,655	192	467
17	25,245	105	2,598	193	461
18	24,505	106	2,542	194	456
19	23,789	107	2,488	195	450
20	23,096	108	2,436	196	444
21	22,427	109	2,385	197	439
22	21,779	110	2,335	198	434
23	21,153	111	2,286	199	429
24	20,547	112	2,238	200	424
25	19,960	113	2,192	201	419
26	19,392	114	2,147	202	415
27	18,843	115	2,103	203	410
28	18,311	116	2,060	204	405
29	17,796	117	2,018	205	401
30	17,297	118	1,977	206	396
31	16,814	119	1,937	207	391
32	16,346	120	1,898	208	386
33	15,892	121	1,860	209	382
34	15,453	122	1,822	210	377
35	15,027	123	1,786	211	372
36	14,614	124	1,750	212	366
37	14,214	125	1,715	213	361
38	13,826	126	1,680	214	356
39	13,449	127	1,647	215	350
40	13,084	128	1,614	216	344
41	12,730	129	1,582	217	338
42	12,387	130	1,550	218	332
43	12,053	131	1,519	219	325
44	11,730	132	1,489	220	318
45	11,416	133	1,459	221	311
46	11,111	134	1,430	222	304
47	10,816	135	1,401	223	297
48	10,529	136	1,373	224	289
49	10,250	137	1,345	225	282
50	9,979	138	1,318		
51	9,717	139	1,291		
52	9,461	140	1,265		
53	9,213	141	1,239		
54	8,973	142	1,214		
55	8,739	143	1,189		
56	8,511	144	1,165		
57	8,291	145	1,141		
58	8,076	146	1,118		
59	7,868	147	1,095		
60	7,665	148	1,072		
61	7,468	149	1,050		
62	7,277	150	1,028		

Table 12B — Sensor Temperature (C) vs Resistance

TEMPERATURE (C)	RESISTANCE (OHMS)	TEMPERATURE (C)	RESISTANCE (OHMS)	TEMPERATURE (C)	RESISTANCE (OHMS)
-32.0	100 049	16.0	7507	64.0	1090
-31.5	97 006	16.5	7334	64.5	1070
-31.0	94 061	17.0	7165	65.0	1050
-30.5	91 209	17.5	7000	65.5	1030
-30.0	88 449	18.0	6840	66.0	1011
-29.5	85 777	18.5	6683	66.5	992
-29.0	83 191	19.0	6531	67.0	973
-28.5	80 687	19.5	6382	67.5	955
-28.0	78 264	20.0	6237	68.0	937
-27.5	75 918	20.5	6096	68.5	919
-27.0	73 648	21.0	5959	69.0	902
-26.5	71 451	21.5	5825	69.5	885
-26.0	69 324	22.0	5694	70.0	868
-25.5	67 265	22.5	5566	70.5	852
-25.0	65 272	23.0	5442	71.0	836
-24.5	63 344	23.5	5321	71.5	820
-24.0	61 477	24.0	5203	72.0	805
-23.5	59 670	24.5	5088	72.5	790
-23.0	57 921	25.0	4976	73.0	775
-22.5	56 228	25.5	4867	73.5	761
-22.0	54 589	26.0	4760	74.0	746
-21.5	53 003	26.5	4656	74.5	733
-21.0	51 467	27.0	4555	75.0	719
-20.5	49 980	27.5	4457	75.5	706
-20.0	48 541	28.0	4360	76.0	693
-19.5	47 148	28.5	4267	76.5	681
-19.0	45 799	29.0	4175	77.0	669
-18.5	44 492	29.5	4086	77.5	657
-18.0	43 228	30.0	4000	78.0	645
-17.5	42 003	30.5	3915	78.5	634
-17.0	40 817	31.0	3832	79.0	623
-16.5	39 668	31.5	3752	79.5	613
-16.0	38 556	32.0	3674	80.0	602
-15.5	37 478	32.5	3597	80.5	592
-15.0	36 435	33.0	3523	81.0	583
-14.5	35 424	33.5	3450	81.5	573
-14.0	34 444	34.0	3379	82.0	564
-13.5	33 495	34.5	3310	82.5	556
-13.0	32 576	35.0	3243	83.0	547
-12.5	31 685	35.5	3177	83.5	539
-12.0	30 821	36.0	3113	84.0	531
-11.5	29 984	36.5	3051	84.5	524
-11.0	29 173	37.0	2990	85.0	516
-10.5	28 386	37.5	2931	85.5	509
-10.0	27 624	38.0	2873	86.0	502
- 9.5	26 884	38.5	2816	86.5	496
- 9.0	26 168	39.0	2761	87.0	489
- 8.5	25 472	39.5	2707	87.5	483
- 8.0	24 798	40.0	2655	88.0	477
- 7.5	24 144	40.5	2603	88.5	472
- 7.0	23 509	41.0	2553	89.0	466
- 6.5	22 893	41.5	2504	89.5	461
- 6.0	22 296	42.0	2457	90.0	456
- 5.5	21 716	42.5	2410	90.5	451
- 5.0	21 153	43.0	2364	91.0	446
- 4.5	20 606	43.5	2320	91.5	441
- 4.0	20 076	44.0	2276	92.0	436
- 3.5	19 561	44.5	2234	92.5	432
- 3.0	19 061	45.0	2192	93.0	427
- 2.5	18 575	45.5	2152	93.5	423
- 2.0	18 103	46.0	2112	94.0	419
- 1.5	17 645	46.5	2073	94.5	415
- 1.0	17 199	47.0	2035	95.0	410
- 0.5	16 766	47.5	1997	95.5	406
0.0	16 346	48.0	1961	96.0	402
0.5	15 937	48.5	1925	96.5	398
1.0	15 539	49.0	1890	97.0	393
1.5	15 153	49.5	1856	97.5	389
2.0	14 777	50.0	1822	98.0	385
2.5	14 412	50.5	1789	98.5	380
3.0	14 057	51.0	1757	99.0	376
3.5	13 711	51.5	1725	99.5	371
4.0	13 375	52.0	1694	100.0	367
4.5	13 048	52.5	1663	100.5	362
5.0	12 730	53.0	1634	101.0	357
5.5	12 420	53.5	1604	101.5	352
6.0	12 119	54.0	1575	102.0	346
6.5	11 826	54.5	1547	102.5	341
7.0	11 541	55.0	1519	103.0	335
7.5	11 263	55.5	1492	103.5	330
8.0	10 992	56.0	1465	104.0	324
8.5	10 729	56.5	1438	104.5	318
9.0	10 472	57.0	1412	105.0	312
9.5	10 223	57.5	1387	105.5	305
10.0	9 979	58.0	1362	106.0	299
10.5	9 742	58.5	1337	106.5	292
11.0	9 512	59.0	1313	107.0	285
11.5	9 287	59.5	1289		
12.0	9 068	60.0	1265		
12.5	8 855	60.5	1242		
13.0	8 647	61.0	1219		
13.5	8 444	61.5	1197		
14.0	8 247	62.0	1175		
14.5	8 055	62.5	1153		
15.0	7 868	63.0	1132		
15.5	7 685	63.5	1111		

SERVICING COOLER (30HK,HL ONLY)

NOTE: The cooler on 30HW units is not serviceable.

When cooler heads and partition plates are removed, tube sheets are exposed showing tube ends as shown in Fig. 23.

⚠ CAUTION

Four tubes in the bundle are secured inside cooler at baffles and *cannot be removed*. These are identified on the tube sheets by a drill mark horizontally adjacent to each of the 4 tubes. See Fig. 23. *If leakage occurs in any of these tubes, plug as described in Tube Plugging section below.*

Tube Plugging — Leaky tube(s) can be plugged until retubing can be done. The number of plugged tubes determines how soon the cooler *must* be retubed. If several tubes require plugging, check with your local Carrier representative to find out how number and location will affect unit capacity.

Figure 24 shows an Elliott tube plug and a cross-sectional view of a plug in place. Table 13 lists the components for plugging.

⚠ CAUTION

Use extreme care when installing plugs to prevent damaging the tube sheet sections between holes.

Clean parts with Locquic “N” solution (or equivalent) and apply a few drops of Loctite No. 675 sealant (or equivalent) to obtain a tight seal without using too much force to set the pin.

Usually plugs can be removed by heating the projecting end of pin to approximately 1000 F (538 C) and chilling quickly with water. Apply heating flame to side of the pin to prevent overheating tube sheet.

RETUBING (See Table 13) — When retubing is to be done, obtain the service of qualified personnel experienced in boiler maintenance and repair. Most standard procedures can be followed when retubing the 10HA coolers. A 6% crush is recommended when rolling replacement tubes into the tube sheet. A 6% crush can be achieved by setting the torque on the gun at 48 to 50 in.-lb (780 to 815 N-m).

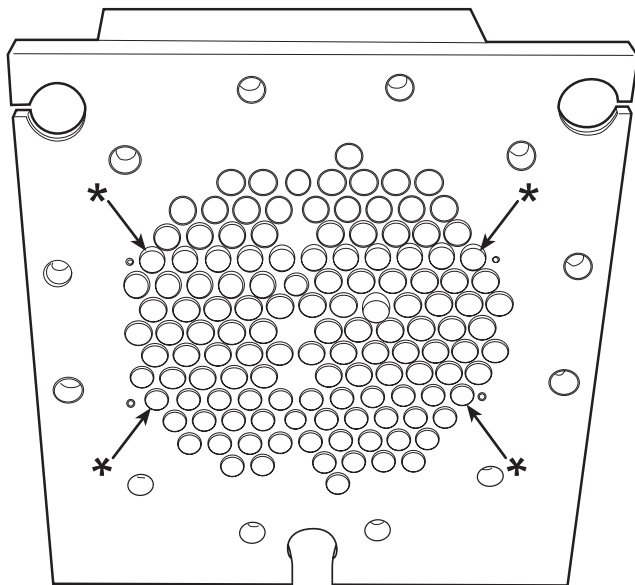

*Four fixed tubes (cannot be removed) identified by adjacent drill points.

Fig. 23 — Typical Tube Sheet

The following Elliott Co. tube rolling tools are required:
 B3400 Expander Assembly
 B3401 Cage
 B3405 Mandrel
 B3408 Rolls

Place one drop of Loctite No. 675 sealant (or equivalent) on top of the tube prior to rolling.

Tube information:

	in.	mm
• Tube sheet hole diameter	0.631	16.03
• Tube OD	0.625	15.87
• Tube ID after rolling	0.581	14.76
(includes expansion due to clearance)	to 0.588	to 14.94

IMPORTANT: Tubes next to gasket webs must be flush with tube sheet (both ends).

Tightening Cooler Head Bolts

GASKET PREPARATION — *When reassembling, use new gaskets.* Compressed non-asbestos/neoprene gaskets (Carrier Material Specification ZA00-32) are to be *momentarily* dipped in compressor break-in oil prior to assembly. Do not soak gaskets in oil, as gasket deterioration results. Use dipped gaskets within 30 minutes to prevent deterioration.

BOLT TORQUES — Apply the following torques during bolt tightening sequence described below:

- 5/8-in. (16-mm) diameter flange bolts 150 to 170 ft-lb (203 to 230 N-m)
- 1/2-in. (13-mm) diameter center-stud nuts 70 to 90 ft-lb (95 to 122 N-m)

Bolt Tightening Sequence (Fig. 25) — The recommended bolt tightening sequence is:

- Step 1** — Tighten all 5/8-in. (16-mm) flange bolts and 1/2-in. (13-mm) center nuts finger tight.
- Step 2** — Following sequence shown in Fig. 25, tighten the bolts and nuts to approximately 50% of specified torque.
- Step 3** — Starting at top (12 o'clock) tighten flange bolts to specified torque (see Bolt Torques section on this page) consecutively in a clockwise direction.
- Step 4** — Tighten center nuts to specified torque.
- Step 5** — No less than one hour later, retighten center nuts.
- Step 6** — After refrigerant is restored to cooler, check center studs and exposed gasket edges for refrigerant leaks with soap solution or a Halide device.

Table 13 — Plugs and Tubes

COMPONENTS FOR PLUGGING	PART NUMBER
For Tubes	
Brass Pin	853103-500*
Brass Ring	853002-570*
For Holes without Tubes	
Brass Pin	853103-1*
Brass Ring	853002-631*
Loctite	No. 675†
Locquic	“N”†

*Order directly from Elliott Tube Co., Dayton, Ohio.

†Can be obtained locally.

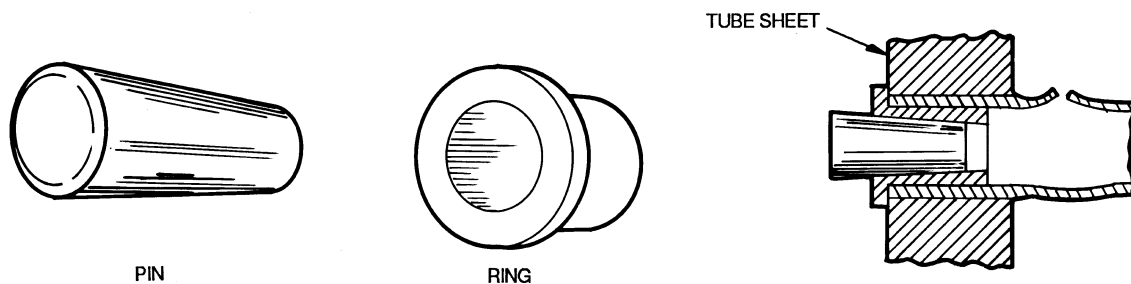

Fig. 24 — Elliott Tube Plug

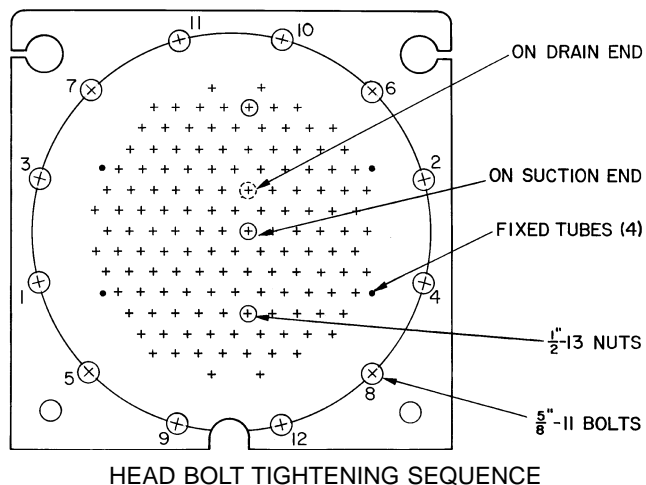

Fig. 25 — Typical Tube Sheet

TROUBLESHOOTING

Complete Unit Stoppage and Restart — Possible causes for unit stoppage and reset methods are (also see Table 14):

GENERAL POWER FAILURE — After power is restored, restart is automatic through the normal timer cycle.

UNIT ON-OFF SWITCH IS OPEN — When the switch is opened, the unit stops immediately. If the switch is closed immediately after it was opened, the unit restarts automatically after the 5-minute timer cycle is completed. If the switch is closed after an extended off-period, the unit restarts automatically in approximately 3 seconds.

CONTACTS OF ANY AUXILIARY INTERLOCKS ARE OPEN — After the problem has been corrected, restart is automatic after completion of the 5-minute timer cycle.

CHILLED FLUID PROOF-OF-FLOW SWITCH(ES) OPEN — After the problem causing the loss of flow has been corrected, restart is automatic after completion of the 5-minute timer cycle.

OPEN LOW-PRESSURE SWITCH — If a low-pressure switch remains open for more than 2 minutes during unit operation, the compressor(s) shuts down and is locked off. The unit service light is illuminated. Determine and correct the cause of the failure. The switch automatically resets, but the unit must be manually reset by cycling the unit control power (move the ON-OFF switch to OFF, then to ON). The unit restarts

after completion of the 5-minute timer cycle unless the refrigerant charge is either very low or lost. If this is the case, determine the cause of the loss of charge, correct the problem, and recharge the unit before restarting.

TEMPERATURE CONTROLLER SHUTS UNIT DOWN ON OUT-OF-RANGE (See Fig. 21) — Check the thermistor for an open circuit failure. See Tables 12A and 12B for temperature-resistance values. If thermistor is damaged, replace it. If thermistor is not damaged, the unit restarts automatically after completion of the 5-minute timer cycle, and after the leaving cooler chilled fluid temperature rises above the upper deadband limit of the temperature controller.

OPEN HIGH-PRESSURE SWITCH(ES) — The unit service light is illuminated. Determine and correct the cause of the failure. The switch(es) automatically resets but the unit must be manually reset by cycling the control power (move ON-OFF switch to OFF, then back to ON). The unit restarts after completion of 5-minute timer cycle.

OPEN COMPRESSOR INTERNAL THERMAL PROTECTION (30HW UNITS) — This is compressor overtemperature protector on 30HW018 units and the discharge gas thermostat (DGT) on 30HW025-040 units. The unit service light is illuminated. Determine and correct cause of problem. The switch resets automatically but unit must be reset by cycling the control power (move ON-OFF switch to OFF, then back to ON). The unit restarts after completion of 5-minute timer cycle.

OPEN OIL PRESSURE SWITCH — If oil pressure switch(es) opens for more than 2 minutes during unit operation, the unit shuts down and is locked off. The unit service light is illuminated. Determine and correct cause of failure. Unit must be reset by cycling the control power (move ON-OFF switch to OFF, then back to ON). Unit restarts after completion of 5-minute timer cycle.

OPEN CONTACTS ON COMPRESSOR GROUND-CURRENT SENSOR(S) (Accessory) — The light-emitting diode (LED) on the ground current accessory board (located in field control wiring section of control box) is illuminated. See Fig. 17-20. Unit service light is also illuminated. **Check the compressor motor windings for a short to ground.** Determine and correct cause of the failure. The unit must be reset by cycling the control power (move ON-OFF switch to OFF, then back to ON). Unit restarts after completion of the 5-minute timer cycle.

OPEN 24-V CONTROL CIRCUIT BREAKER(S) — Determine the cause of the failure and correct. Reset circuit breaker(s). Restart is automatic after completion of 5-minute timer cycle.

COOLING LOAD SATISFIED — Unit shuts down if cooling load is satisfied. Unit restarts if required after completion of 5-minute timer cycle.

THERMISTOR FAILURE — If thermistor fails in open mode, the temperature controller shuts down the unit in an out-of-range condition. Replace the thermistor. Unit restarts automatically after completion of a 5-minute timer cycle, and when the leaving cooler chilled fluid temperature rises above the upper deadband limit of the temperature controller.

NOTE: If the thermistor fails in closed mode, the temperature controller keeps trying to load up.

⚠ CAUTION

If unit stoppage occurs more than once as a result of any of the safety devices listed, determine and correct cause before attempting another restart.

Table 14 — Troubleshooting

SYMPTOMS	CAUSE	REMEDY	
Compressor does not run	Power line open	Reset circuit breaker.	
	Control fuse or circuit breaker opens	Check control circuit for ground or short. Reset breaker and replace fuse.	
	Compressor overtemperature sensor open	Find cause of high temperature and reset controls.	
	Tripped power breaker	Check the controls. Find the cause of trip and reset breaker.	
	Condenser circulating pump not running	Power off — restart.	
		Pump binding — free pump.	
		Incorrect wiring — rewire.	
		Pump motor burned out — replace.	
	Loose terminal connection	Check connections.	
	Improperly wired controls	Check wiring and rewire if necessary.	
Low line voltage	Check line voltage — determine location of voltage drop and remedy deficiency.		
Compressor motor defective	Check motor winding for open or short. Replace compressor if necessary.		
Seized compressor	Replace compressor.		
Compressor cycles off on loss of charge	Loss of charge control erratic in action	Repair leak and recharge.	
		Replace control.	
	Low refrigerant charge	Add refrigerant.	
	Low suction temperature	Raise cooler leaving fluid temperature set point.	
	Compressor suction valve leaking	Replace valve plate.	
Plugged compressor suction strainer	Clean or replace strainer.		
Compressor suction shutoff valve partially closed	Open valve.		
Compressor cycles off on out of range condition	Thermistor failure	Replace thermistor.	
	System load was reduced faster than controller could remove stages	Unit will restart after fluid temperature rises back into the control band. Avoid rapidly removing system load.	
Compressor cycles control steps rapidly	Temperature controller deadband setting is too low	Raise deadband setting.	
Compressor shuts down on high-pressure control	High-pressure control acting erratically	Replace control.	
	Compressor discharge valve partially closed	Open valve or replace (if defective).	
	Air in system	Purge system.	
	Condenser scaled/dirty	Clean condenser.	
	Receiver not properly vented — refrigerant backs up into evaporator condenser	Repipe as required to provide adequate venting.	
	Condenser water pump or fans not operating	Start pump — repair or replace if defective.	
	System overcharged with refrigerant	Reduce charge.	
Unit operates too long or continuously	Low refrigerant charge	Add refrigerant.	
	Control contacts fused	Replace control.	
	Air in system	Purge system.	
	Partially plugged or plugged expansion valve or filter drier	Clean or replace as needed.	
	Defective insulation	Replace or repair as needed.	
	Service load	Keep doors and windows closed.	
	Inefficient compressor	Check valves, and replace if necessary.	
Unusual or loud system noises	Piping vibration	Support piping as required.	
		Check for loose pipe connections.	
	Expansion valve hissing	Add refrigerant.	
		Check for plugged liquid line filter drier.	
	Compressor noisy	Check valve plates for valve noise.	
Replace compressor (worn bearings). Check for loose compressor holddown bolts.			

Table 14 — Troubleshooting (cont)

SYMPTOMS	CAUSE	REMEDY
Compressor loses oil	Leak in system	Repair leak.
	Mechanical damage (blown piston or broken discharge valve)	Repair damage or replace compressor as needed.
	Oil trapped in line	Check piping for oil traps.
	Crankcase heater not energized during shutdown	Check wiring and crankcase heater contacts on the temperature controller, and replace heater if necessary.
Hot liquid line	Shortage of refrigerant due to leak	Repair leak and recharge.
Frosted liquid line	Shutoff valve partially closed or restricted	Open valve or remove restriction.
	Restricted filter drier	Replace filter drier.
Frosted suction line	Expansion valve admitting excess refrigerant	Adjust expansion valve. Replace valve if defective.
Compressor will not unload	Burned-out coil	Replace coil.
	Defective capacity control valve	Replace valve.
	Miswired solenoid	Rewire correctly.
	Weak, broken, or wrong valve body spring	Replace spring.
Compressor will not load	Miswired solenoid	Rewire correctly.
	Defective capacity control valve	Replace valve.
	Plugged strainer (high side)	Clean or replace strainer.
	Stuck or damaged unloader piston or piston ring(s)	Clean or replace the necessary parts.
System noises	Piping vibration	Support piping as required.
		Check for loose pipe connectors.
	Expansion valve hissing	Add refrigerant.
		Check for plugged liquid line strainer.
	Compressor noisy	Check valve plates for valve noise.
		Replace compressor (worn bearings). Check for loose compressor holddown bolts.
Freeze-up	Improper charging	Make sure a full quantity of fluid is flowing through the cooler while charging, and suction pressure in cooler is equal to or greater than pressure corresponding to 32 F (0° C) (58 psig [400 kPa] for Refrigerant 22).
	Improperly set safety thermostat	Check safety thermostat for proper setting at beginning of each season.
	Operating with safety thermostat bypassed	If thermostat was bypassed for checking, be sure it is back in circuit before starting unit.
	Improper circulation of condenser water	Use adequately sized cleanable strainer in the condenser water circuit. Make sure strainer is clean. It may sometimes be necessary to chemically treat the water to prevent formation of deposits.
	System not drained for winter shutdown	Remove drain plugs at end of cooling season. Blow out any residual water. Instead of draining, a suitable anti-freeze may be added to the water. <i>Damage to chiller due to freezing is considered abuse and is not covered by warranty.</i>
	Loose Thermistor	Tighten thermistor to pipe and reinsulate (30HW).

SERVICE TRAINING

Packaged Service Training programs are an excellent way to increase your knowledge of the equipment discussed in this manual, including:

- Unit Familiarization
- Installation Overview
- Maintenance
- Operating Sequence

A large selection of product, theory, and skills programs are available, using popular video-based formats and materials. All include video and/or slides, plus companion book.

Classroom Service Training which includes “hands-on” experience with the products in our labs can mean increased confidence that really pays dividends in faster troubleshooting and fewer callbacks. Course descriptions and schedules are in our catalog.

CALL FOR FREE CATALOG 1-800-962-9212

Packaged Service Training Classroom Service Training

B. Preliminary Equipment Check (YES or NO) (cont)

HAVE POWER SIDE ELECTRICAL COMPONENT CONNECTIONS BEEN CHECKED FOR TIGHTNESS? _____

ON 30HK,HL UNITS, IS THE PROPER CONTROL VOLTAGE SUPPLIED TO TB2-1 AND TB2-3? _____

ON 30HK,HL 50 HZ UNITS, IS THE BLACK WIRE GOING TO TRAN1 AND TRAN2 CONNECTED TO THE RED LEAD FROM THE TRANSFORMER? _____

CHECK AIR SYSTEMS (YES OR NO)

ARE ALL AIR HANDLERS OPERATING? (refer to air-handling equipment Installation and Start-Up Instructions) _____

ARE ALL CHILLED FLUID VALVES OPEN? _____

IS THE FLUID PIPING CONNECTED PROPERLY? _____

HAS ALL AIR BEEN VENTED FROM THE COOLER LOOP? _____

IS THE CHILLED WATER (FLUID) PUMP (CWP) OPERATING? _____

IS THE CWP ROTATION CORRECT?

CWP MOTOR AMPERAGE: Rated _____ Actual _____

C. Unit Start-Up (insert check mark as each item is completed)

HAS THE CHILLER BEEN PROPERLY INTERLOCKED WITH THE AUXILIARY CONTACTS OF THE CONDENSER WATER PUMP STARTER? _____

ASSURE THAT UNIT IS SUPPLIED WITH CORRECT CONTROL VOLTAGE POWER. _____

ASSURE CRANKCASE HEATERS HAVE BEEN ENERGIZED FOR A MINIMUM OF **24 HOURS** PRIOR TO START-UP. _____

ASSURE COMPRESSOR OIL LEVEL IS CORRECT. _____

ASSURE LIQUID LINE SERVICE VALVE(S) IS BACKSEATED. _____

ASSURE COMPRESSOR DISCHARGE SERVICE VALVE(S) IS BACKSEATED. _____

ASSURE COMPRESSOR SUCTION SERVICE VALVE(S) IS BACKSEATED. _____

LOOSEN COMPRESSOR SHIPPING ISOLATOR LOCKNUTS. _____

OPEN GAGE PANEL SERVICE VALVES. _____

BE SURE TEMPERATURE CONTROLLER DEADBAND AND SAMPLE RATE SETTINGS ARE SET. _____

SET POINT SHOULD BE ADJUSTED TO THE DESIRED COOLER LEAVING FLUID TEMPERATURE. (refer to installation instructions) _____

LEAK CHECK **THOROUGHLY**: COMPRESSOR(S), CONDENSER FITTINGS, TXV(s), SOLENOID VALVE(S), FILTER DRIER(S), FUSIBLE PLUG(S), AND COOLER HEAD(S), WITH GENERAL ELECTRIC H-10-B ELECTRONIC LEAK DETECTOR. _____

LOCATE, REPAIR, AND REPORT ANY R-22 LEAKS. _____

CHECK VOLTAGE IMBALANCE: AB _____ AC _____ BC _____

AB + AC + BC (divided by 3) = AVERAGE VOLTAGE = _____ V

MAXIMUM DEVIATION FROM AVERAGE VOLTAGE = _____

VOLTAGE IMBALANCE = $\frac{(\text{MAX. DEVIATION})}{\text{AVERAGE VOLTAGE}} \times 100 =$ _____ % VOLTAGE IMBALANCE

IF OVER 2% VOLTAGE IMBALANCE, DO NOT ATTEMPT TO START CHILLER!
CALL LOCAL POWER COMPANY FOR ASSISTANCE.

ASSURE THAT INCOMING POWER VOLTAGE TO CHILLER IS WITHIN RATED UNIT VOLTAGE RANGE. _____

SYSTEM FLUID VOLUME IN LOOP: TYPE SYSTEM:

AIR CONDITIONING — MINIMUM 3 GAL. (3.25 L) PER NOMINAL TON (kW) = _____ GAL. (L)

PROCESS COOLING — MINIMUM 6 GAL. (6.5 L) PER NOMINAL TON (kW) = _____ GAL. (L)

C. Unit Start-Up (cont)

COOLER LOOP PROTECTION IF REQUIRED:

GALLONS (LITERS) OF BRINE ADDED: _____

PIPING INCLUDES ELECTRIC TAPE HEATERS. _____

CHECK PRESSURE DROP ACROSS COOLER.

FLUID ENTERING COOLER: _____ PSIG (kPa)

FLUID LEAVING COOLER: _____ PSIG (kPa)

(PSIG DIFFERENCE) x 2.31 = FT OF FLUID PRESSURE DROP = _____

(kPa DIFFERENCE) x .335 = FT OF FLUID PRESSURE DROP = _____

PLOT COOLER PRESSURE DROP ON PERFORMANCE DATA CHART (LOCATED IN PRODUCT DATA LITERATURE) TO DETERMINE TOTAL GPM (L/s).

TOTAL GPM (L/s) = _____ UNIT'S RATED MIN. GPM (L/s) = _____

GPM (L/s) PER TON = _____ UNIT'S RATED MIN. PRESSURE DROP = _____
(Refer to product data literature.)

JOB'S SPECIFIED GPM (L/s) (if available) _____

NOTE: IF UNIT HAS LOW FLUID FLOW, FIND SOURCE OF PROBLEM: CHECK FLUID PIPING, IN-LINE FLUID STRAINER, SHUT-OFF VALVES, CHILLED FLUID PUMP ROTATION, ETC.

COOLER LOOP PROTECTION:

GAL. (L) OF BRINE ADDED (IF REQUIRED). _____

IN-LINE WATER STRAINER INSTALLED ADJACENT TO COOLER FLUID INLET. (REQUIRED FOR 30HW COOLERS.)

YES _____ NO _____

CONDENSER PROTECTION:

IN-LINE MINIMUM 20-MESH STRAINER INSTALLED ADJACENT TO THE CONDENSER WATER INLET.

YES _____ NO _____

TO START THE CHILLER: (insert check mark as each item is completed)

PLACE ON-OFF SWITCH IN THE ON POSITION. _____

ASSUMING THERE IS A CALL FOR CHILLED FLUID, THE COMPRESSOR WILL START UNLOADED AFTER A 6-SECOND TO 5-MINUTE DELAY (DEPENDING ON THE TIMING LOGIC). _____

THE LOW-PRESSURE SWITCH (ALL UNITS) AND OIL-PRESSURE SWITCH (30HL, HWA UNITS — ACCESSORY ON 30HK, HWB, HWC, HWS UNITS) ARE BYPASSED FOR 2 MINUTES. _____

IF ADDITIONAL CAPACITY IS REQUIRED AFTER THE 2-MINUTE PERIOD, COMPRESSOR WILL LOAD UP.

MEASURE THE FOLLOWING: WHILE MACHINE IS IN STABLE OPERATING CONDITION.

SUCTION PRESSURE _____

SUCTION LINE TEMP. _____

SUCTION SUPERHEAT _____

DISCHARGE PRESSURE _____

DISCHARGE LINE TEMP. _____

DISCHARGE SUPERHEAT _____

CHECK AND ADJUST SUCTION SUPERHEAT (9 to 11 F [5 to 6 C]). _____

NOTES:

Free Manuals Download Website

<http://myh66.com>

<http://usermanuals.us>

<http://www.somanuals.com>

<http://www.4manuals.cc>

<http://www.manual-lib.com>

<http://www.404manual.com>

<http://www.luxmanual.com>

<http://aubethermostatmanual.com>

Golf course search by state

<http://golfingnear.com>

Email search by domain

<http://emailbydomain.com>

Auto manuals search

<http://auto.somanuals.com>

TV manuals search

<http://tv.somanuals.com>