

DELPHI SERIES



FEATURES

- ◆ High efficiency: 88%@ $\pm 12.1\text{V}/2.7\text{A}$
- ◆ Size: 57.9mm x 36.8mm x 9.7mm
(2.28" x 1.45" x 0.38")
- ◆ Industry standard pin out
- ◆ Fixed frequency operation
- ◆ Input UVLO, Output OCP, OVP, OTP
- ◆ 2250V isolation
- ◆ No minimum load required
- ◆ Adjustable output voltage
- ◆ ISO 9001, TL 9000, ISO 14001, QS9000, OHSAS18001 certified manufacturing facility
- ◆ UL/cUL 60950-1 (US & Canada), and TUV (EN60950-1) - pending

Delphi Series Q48DC, 65W Quarter Brick Dual Output DC/DC Power Modules: 48V in, $\pm 12.1\text{V}$, 2.7A Output

The Delphi Series Q48DC second generation Quarter Brick, 48V input, positive and negative bipolar dual output, and isolated DC/DC converters are the latest offering from a world leader in power system and technology and manufacturing — Delta Electronics, Inc. The Q48DC product family is the second generation in the bipolar dual output series and it provides even more cost effective solution of positive and negative bipolar output (output voltage is 12.1V) and up to 65 watts of power in an industry standard quarter brick package size. Both output channels can be used independently. With creative design technology and optimization of component placement, these converters possess outstanding electrical and thermal performance, as well as extremely high reliability under highly stressful operating conditions. All models are fully protected from abnormal input/output voltage, current, and temperature conditions. The Delphi Series converters meet all safety requirements with basic insulation.

OPTIONS

- ◆ Positive On/Off logic
- ◆ Output OVP hiccup available

APPLICATIONS

- ◆ Telecom / DataCom
- ◆ Wireless Networks
- ◆ Optical Network Equipment
- ◆ Server and Data Storage
- ◆ Industrial / Test Equipment

PRELIMINARY DATASHEET

DS_Q48DC12003_03112008



TECHNICAL SPECIFICATIONS

(T_A=25°C, airflow rate=300 LFM, V_{in}=48Vdc, nominal V_{out} unless otherwise noted.)

PARAMETER	NOTES and CONDITIONS	Q48DC12003NR A				
		Min.	Typ.	Max.	Units	
ABSOLUTE MAXIMUM RATINGS						
Input Voltage						
Continuous				80	Vdc	
Transient	100ms			100	Vdc	
Operating Temperature	Refer to Figure 20 for measuring point	-40		124	°C	
Storage Temperature		-55		125	°C	
Input/Output Isolation Voltage				2250	Vdc	
INPUT CHARACTERISTICS						
Operating Input Voltage		36	48	75	Vdc	
Input Under-Voltage Lockout						
Turn-On Voltage Threshold		32	33.5	35	Vdc	
Turn-Off Voltage Threshold		29	30.5	32	Vdc	
Lockout Hysteresis Voltage		2	3	4	Vdc	
Maximum Input Current	100% Load, 36Vin			2.4	A	
No-Load Input Current			50		mA	
Off Converter Input Current				10	mA	
Inrush Current(I [†])				1	A ² s	
Input Reflected-Ripple Current	P-P thru 12μH inductor, 5Hz to 20MHz			20	mA	
Input Voltage Ripple Rejection	120Hz		66		dB	
OUTPUT CHARACTERISTICS						
Output Voltage Set Point	Vin=48V, Io=Io, Max, Tc=25°C	Vout 1,2	±11.98	±12.10	±12.22	V
Output Voltage Regulation						
Over Load	Io1=Io2=Io, min to Io, max	Vout 1,2		±20	±180	mV
Over Line	Vin=36V to 75V, Io1=Io2=full load	Vout 1,2		±20	±120	mV
Cross Regulation	Io1-Io2 <20% Io,max				±360	mV
Over Temperature	Tc=-40°C to 129°C, Io1=Io2= Io, min to Io, max			±120		mV
Total Output Voltage Range	Over all load, line and temperature		±11.74		±12.46	V
Output Voltage Ripple and Noise	5Hz to 20MHz bandwidth					
Peak-to-Peak	Io1, Io2 Full Load, 1μF ceramic, 10μF tantalum	Vout 1, 2		40	80	mV
RMS	Io1, Io2 Full Load, 1μF ceramic, 10μF tantalum	Vout 1, 2		10	30	mV
Operating Output Current Range		Vout 1, 2	0		2.7	A
Output DC Current-Limit Inception	Iout 1 + Iout 2		7.1		9	A
DYNAMIC CHARACTERISTICS						
Output Voltage Current Transient	48V, 10μF Tan & 1μF Ceramic load cap, 0.1A/μs					
Positive Step Change in Output Current	Iout1 or Iout2 from 50% Io, max to 75% Io, max	Vout 1		400	600	mV
		Vout 2		400	600	
Negative Step Change in Output Current	Iout2 or Iout1 from 75% Io,max to 50% Io, max	Vout 1		400	600	mV
		Vout 2		400	600	
Cross dynamic				±120	±360	mV
Settling Time (within 1% Vout nominal)				100		us
Turn-On Transient						
Delay Time, From On/Off Control				2		ms
Delay Time, From Input				2		ms
Start-up Time, From On/Off Control				20	30	ms
Start-up Time, From Input				20	30	ms
Maximum Output Capacitance	Full load; 5% overshoot of Vout at startup				5000	μF
EFFICIENCY						
100% Load	Iout1, Iout2 full load			88		%
60% Load	Iout1, Iout2 60% of full load			86.5		%
ISOLATION CHARACTERISTICS						
Input to Output	<1 minute				2250	Vdc
Isolation Resistance			10			MΩ
Isolation Capacitance				1500		pF
FEATURE CHARACTERISTICS						
Switching Frequency				330		kHz
ON/OFF Control, (Logic Low-Module ON)						
Logic Low	Von/off at Ion/off=1.0mA		-0.7		1.8	V
Logic High	Von/off at Ion/off=0.0 μA		3.5		12	V
ON/OFF Current	Ion/off at Von/off=0.0V				1	mA
Leakage Current	Logic High, Von/off=15V				300	uA
Output Voltage Trim Range	Pout ≤ max rated power (65W)		-17		+5	%
	Iout ≤ max 120% rated Iout		-25		-17	%
Output Over-Voltage Protection	Over full temp range; % of nominal Vout		124	130	150	%
GENERAL SPECIFICATIONS						
MTBF	Io=80% of Io, max; Ta=40°C			TBD		M hours
Weight				31		grams
Over-Temperature Shutdown	Refer to Figure 20 for measuring point			129		°C

ELECTRICAL CHARACTERISTICS CURVES

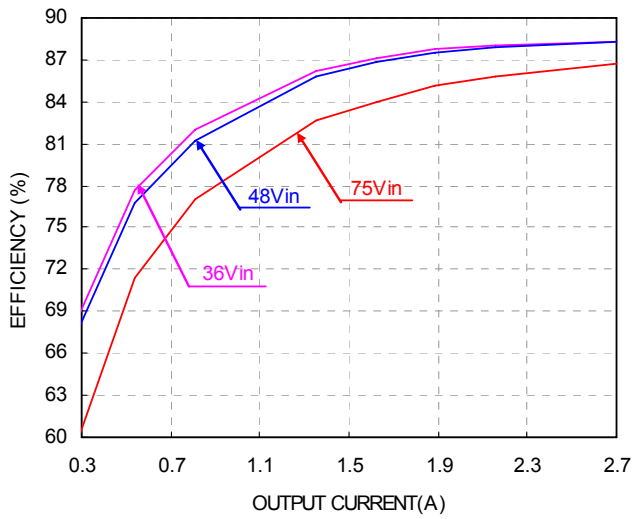

Figure 1: Efficiency vs. load current for minimum, nominal, and maximum input voltage at 25°C. $I_{o1}=I_{o2}$.

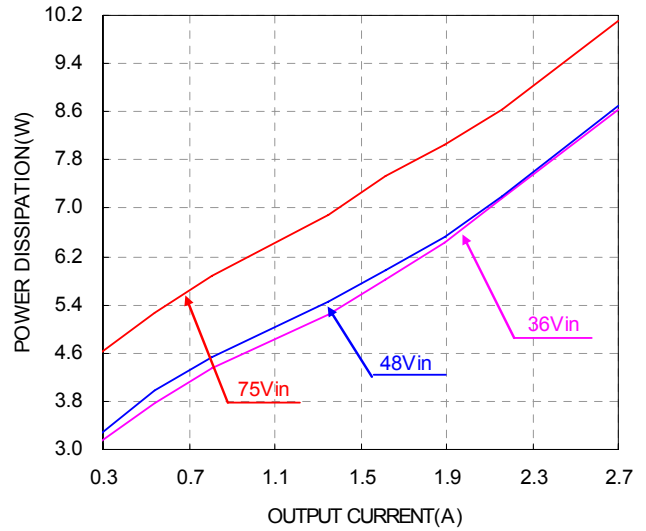

Figure 2: Power dissipation vs. load current for minimum, nominal, and maximum input voltage at 25°C. $I_{o1}=I_{o2}$.

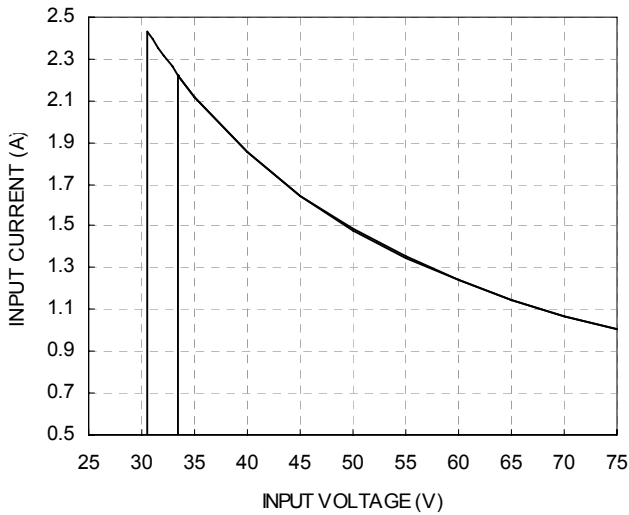

Figure 3: Typical input characteristics at room temperature ($I_o=full\ load$).

ELECTRICAL CHARACTERISTICS CURVES

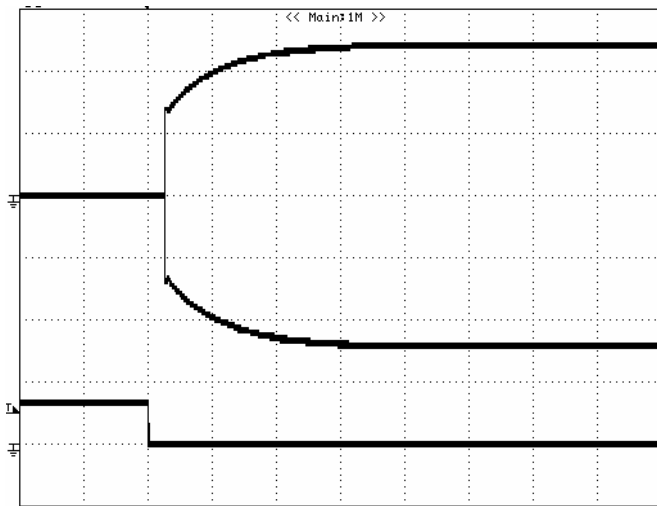

Figure 4: Turn-on transient at zero load current (10ms/div). $V_{in}=48V$. Top Trace: V_{out} : 5V/div; Bottom Trace: ON/OFF input: 5V/div.

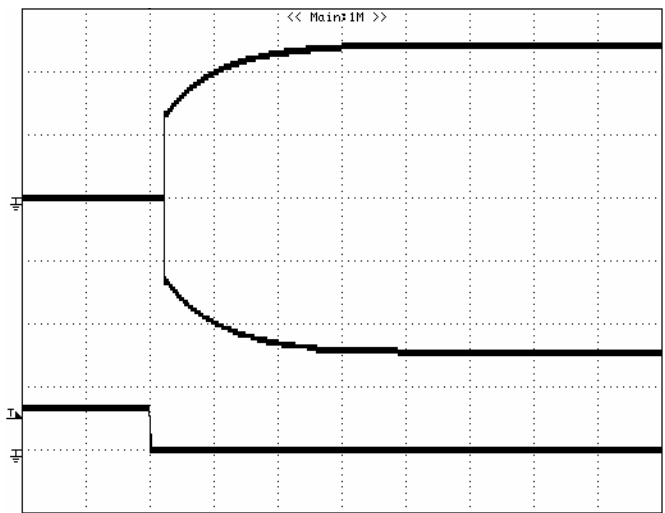

Figure 5: Turn-on transient at full rated load current (resistive load) (10 ms/div). $V_{in}=48V$. Top Trace: V_{out} ; 5V/div; Bottom Trace: ON/OFF input: 5V/div.

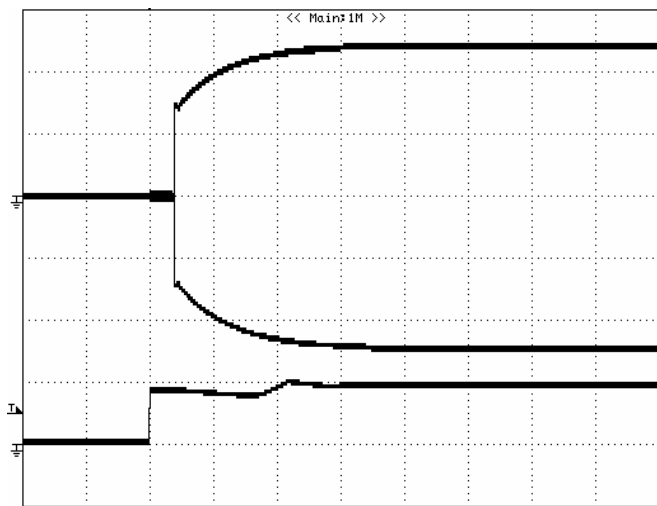

Figure 6: Turn-on transient at zero load current (10ms/div). $V_{in}=48V$. Top Trace: V_{out} : 5V/div; Bottom Trace: V_{in} input: 50V/div.

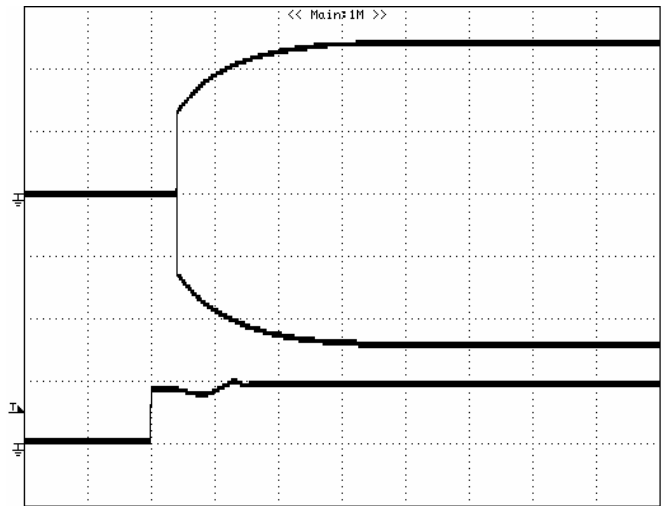

Figure 7: Turn-on transient at full rated load current (resistive load) (10 ms/div). $V_{in}=48V$. Top Trace: V_{out} ; 5V/div; Bottom Trace: V_{in} input: 50V/div.

ELECTRICAL CHARACTERISTICS CURVES

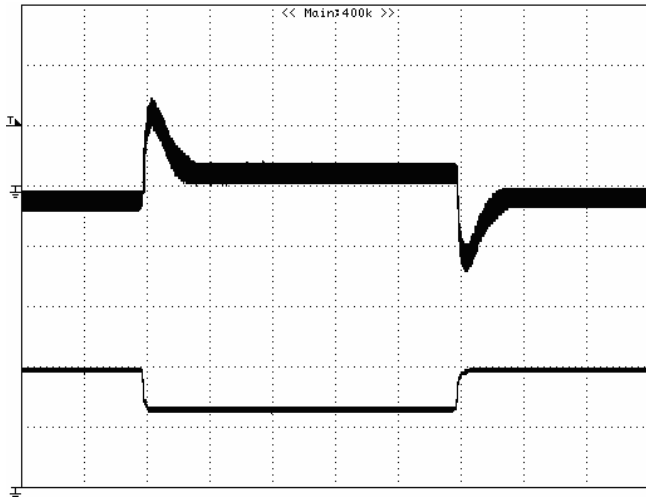

Figure 8: Output voltage response to step-change in load current Iout1 (75%-50%-75% of Io, max; di/dt = 0.1A/μs, 200uS/DIV). Vin=48V. Load cap: 10μF, tantalum capacitor and 1μF ceramic capacitor. Top trace: Vout (100mV/div), Bottom trace: Iout (1A/div). Scope measurement should be made using a BNC cable (length short than 20 inch). Position the load between 51 mm and 76 mm (2inch and 3 inch) from the module.

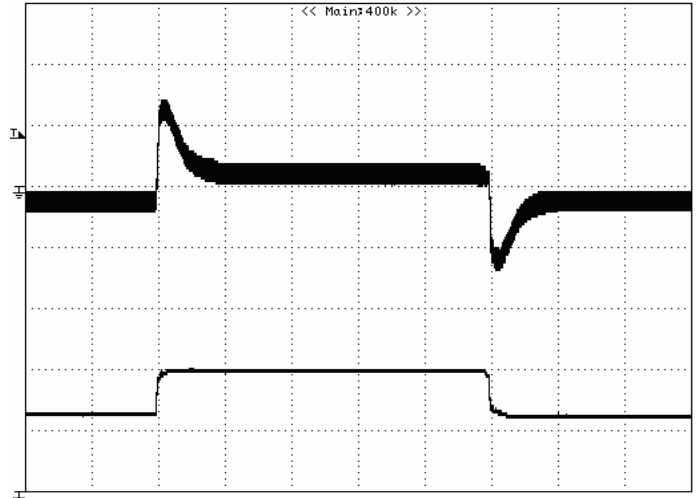

Figure 9: Output voltage response to step-change in load current Iout2 (75%-50%-75% of Io, max; di/dt = 0.1A/μs, 200uS/DIV). Vin=48V. Load cap: 10μF, tantalum capacitor and 1μF ceramic capacitor. Top trace: Vout (100mV/div), Bottom trace: Iout (1A/div). Scope measurement should be made using a BNC cable (length short than 20 inch). Position the load between 51 mm and 76 mm (2inch and 3 inch) from the module.

ELECTRICAL CHARACTERISTICS CURVES

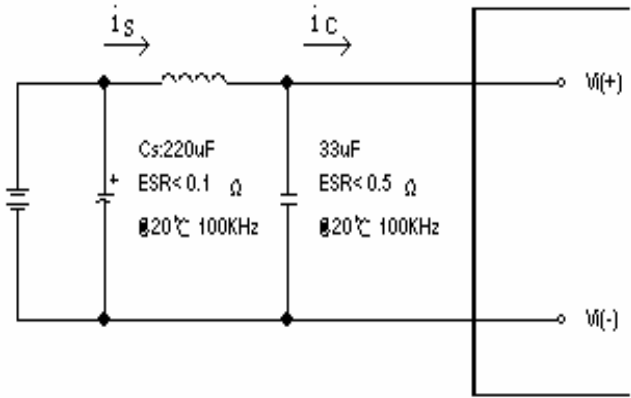

Figure 10: Test set-up diagram showing measurement points for Input Terminal Ripple Current and Input Reflected Ripple Current.

Note: Measured input reflected-ripple current with a simulated source Inductance (L_{TEST}) of $12 \mu H$. Capacitor C_s offset possible battery impedance. Measure current as shown above.

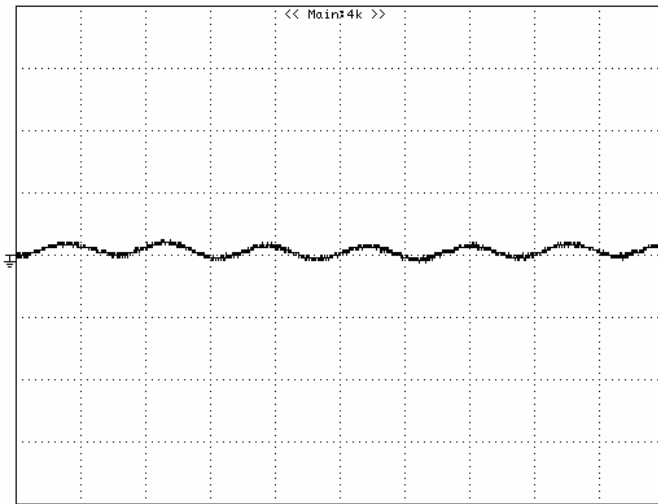

Figure 12: Input reflected ripple current, i_s , through a $12 \mu H$ source inductor at nominal input voltage and rated load current (20 mA/div).

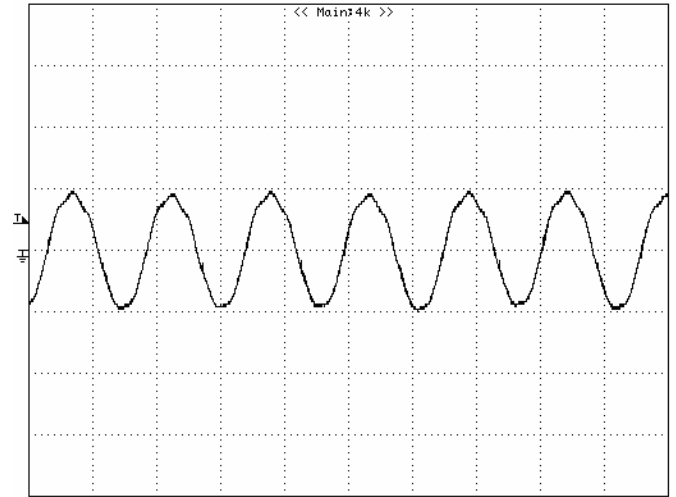

Figure 11: Input Terminal Ripple Current, i_c , at full rated output current and nominal input voltage with $12 \mu H$ source impedance and $33 \mu F$ electrolytic capacitor (500 mA/div).

ELECTRICAL CHARACTERISTICS CURVES

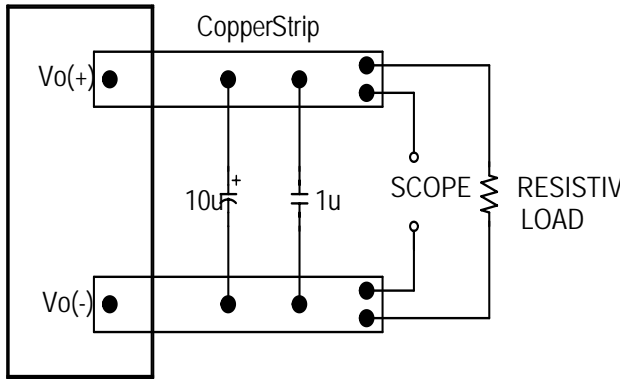

Figure 13: Output voltage noise and ripple measurement test setup.

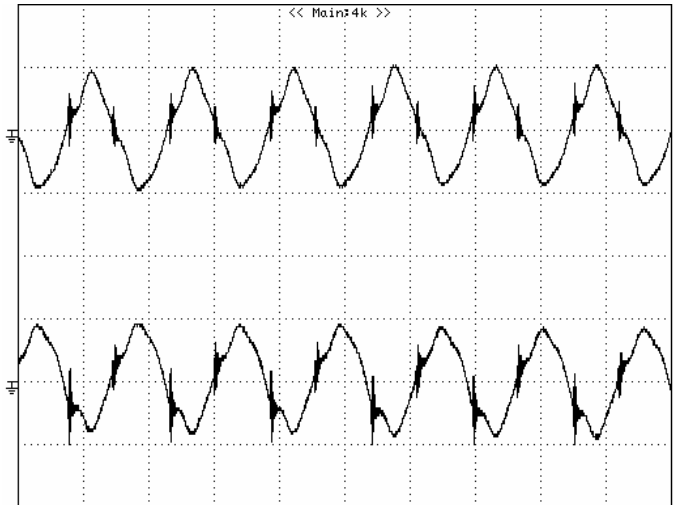

Figure 14: Output voltage ripple at nominal input voltage ($V_{in}=48V$) and rated load current ($I_{o1}=I_{o2}=2.7A$, 20 mV/div). Load capacitance: $1\mu F$ ceramic capacitor and $10\mu F$ tantalum capacitor. Bandwidth: 20 MHz . (See Figure 13). Scope measurement should be made using a BNC cable (length short than 20 inch). Position the load between 51 mm and 76 mm (2inch and 3 inch) from the module.

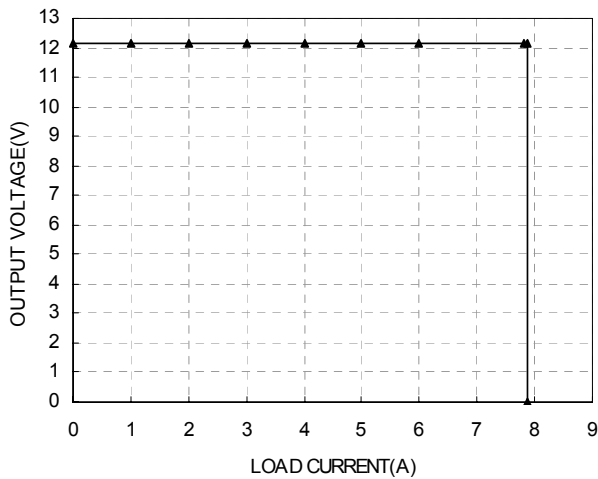

Figure 15: Output voltage vs. load current showing typical current limit curves and converter shutdown points.

DESIGN CONSIDERATIONS

Input Source Impedance

The impedance of the input source connecting to the DC/DC power modules will interact with the modules and affect the stability. A low ac-impedance input source is recommended. If the source inductance is more than a few μH , we advise adding a 10 to 100 μF electrolytic capacitor (ESR $< 0.7 \Omega$ at 100 kHz) mounted close to the input of the module to improve the stability.

Layout and EMC Considerations

Delta's DC/DC power modules are designed to operate in a wide variety of systems and applications. For design assistance with EMC compliance and related PWB layout issues, please contact Delta's technical support team. An external input filter module is available for easier EMC compliance design. Application notes to assist designers in addressing these issues are pending release.

Safety Considerations

The power module must be installed in compliance with the spacing and separation requirements of the end-user's safety agency standard, i.e., UL60950, CAN/CSA-C22.2 No. 60950-00 and EN60950:2000 and IEC60950-1999, if the system in which the power module is to be used must meet safety agency requirements.

When the input source is 60 Vdc or below, the power module meets SELV (safety extra-low voltage) requirements. If the input source is a hazardous voltage which is greater than 60 Vdc and less than or equal to 75 Vdc, for the module's output to meet SELV requirements, all of the following must be met:

- The input source must be insulated from any hazardous voltage, including the ac mains, with reinforced insulation.
- One V_i pin and one V_o pin are grounded, or all the input and output pins are kept floating.
- The input terminals of the module are not operator accessible.
- If the metal baseplate is grounded the output must be also grounded.
- A SELV reliability test is conducted on the system where the module is used to ensure that under a single fault, hazardous voltage does not appear at the module's output.

Do not ground one of the input pins without grounding one of the output pins. This connection may allow a non-SELV voltage to appear between the output pin and ground.

The power module has extra-low voltage (ELV) outputs when all inputs are ELV.

This power module is not internally fused. To achieve optimum safety and system protection, an input line fuse is highly recommended. The safety agencies require a normal-blow fuse with 7A maximum rating to be installed in the ungrounded lead. A lower rated fuse can be used based on the maximum inrush transient energy and maximum input current.

Soldering and Cleaning Considerations

Post solder cleaning is usually the final board assembly process before the board or system undergoes electrical testing. Inadequate cleaning and/or drying may lower the reliability of a power module and severely affect the finished circuit board assembly test. Adequate cleaning and/or drying is especially important for un-encapsulated and/or open frame type power modules. For assistance on appropriate soldering and cleaning procedures, please contact Delta's technical support team.

FEATURES DESCRIPTIONS

Over-Current Protection

The modules include an internal output over-current protection circuit, which will endure current limiting for an unlimited duration during output overload. If the output current exceeds the OCP set point, the modules will automatically shut down (hiccup mode).

The modules will try to restart after shutdown. If the overload condition still exists, the module will shut down again. This restart trial will continue until the overload condition is corrected.

Over-Voltage Protection

The modules include an internal output over-voltage protection circuit, which monitors the voltage on the output terminals. If this voltage exceeds the over-voltage set point, the module will shut down and latch off. The over-voltage latch is reset by either cycling the input power or by toggling the on/off signal for one second.

Over-Temperature Protection

The over-temperature protection consists of circuitry that provides protection from thermal damage. If the temperature exceeds the over-temperature threshold the module will shut down.

The module will try to restart after shutdown. If the over-temperature condition still exists during restart, the module will shut down again. This restart trial will continue until the temperature is within specification.

Remote On/Off

The remote on/off feature on the module can be either negative or positive logic. Negative logic turns the module on during a logic low and off during a logic high. Positive logic turns the modules on during a logic high and off during a logic low.

Remote on/off can be controlled by an external switch between the on/off terminal and the Vi(-) terminal. The switch can be an open collector or open drain.

For negative logic if the remote on/off feature is not used, please short the on/off pin to Vi(-). For positive logic if the remote on/off feature is not used, please leave the on/off pin to floating.

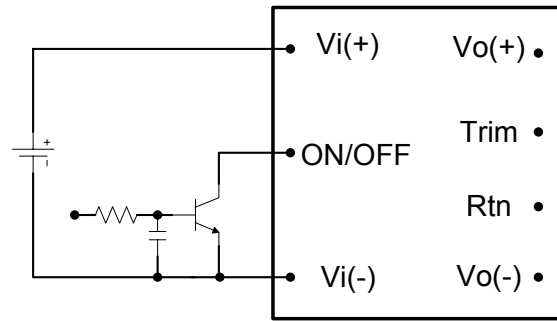

Figure 16: Remote on/off implementation

FEATURES DESCRIPTIONS (CON.)

Output Voltage Adjustment (TRIM)

To increase or decrease the output voltage set point, the modules may be connected with an external resistor between the TRIM pin and either the Vo(+) or Vo(-). The TRIM pin should be left open if this feature is not used.

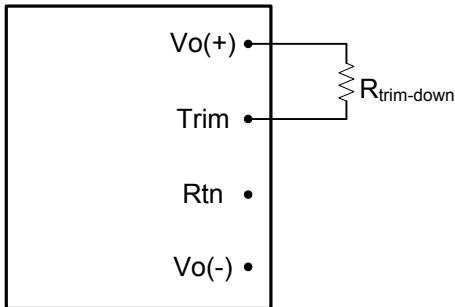

Figure 17: Circuit configuration for trim-down (decrease output voltage)

If the external resistor is connected between the TRIM and Vo(+) pins, the output voltage set point decreases (Fig.17). The external resistor value required to obtain a percentage of output voltage change $\Delta\%$ is defined as:

$$R_{trim-down} = \left[\frac{749}{\Delta} - 9.46 \right] (K\Omega)$$

Ex. When Trim-down -25%(12.1V×0.75=9.08V)

$$R_{trim-down} = \left[\frac{749}{25} - 9.46 \right] (K\Omega) = 20.5(K\Omega)$$

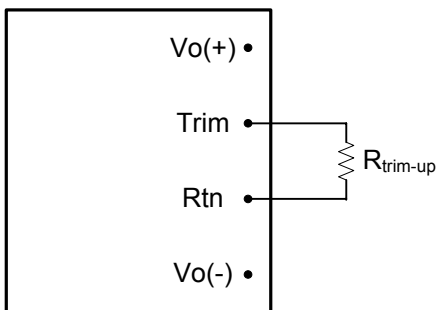

Figure 18: Circuit configuration for trim-up (increase output voltage)

If the external resistor is connected between the TRIM and Rtn the output voltage set point increases (Fig.18). The external resistor value required to obtain a percentage output voltage change $\Delta\%$ is defined as:

$$R_{trim-up} = \frac{197}{\Delta} (K\Omega)$$

Ex. When Trim-up +5%(12.1V×1.05=12.71V)

$$R_{trim-up} = \frac{197}{5} = 39.4(K\Omega)$$

When using trim, the output voltage of the module is usually increased, which increases the power output of the module with the same output current.

Care should be taken to ensure that the maximum output power of the module remains at or below the maximum rated power.

THERMAL CONSIDERATIONS

Thermal management is an important part of the system design. To ensure proper, reliable operation, sufficient cooling of the power module is needed over the entire temperature range of the module. Convection cooling is usually the dominant mode of heat transfer.

Hence, the choice of equipment to characterize the thermal performance of the power module is a wind tunnel.

Thermal Testing Setup

Delta's DC/DC power modules are characterized in heated vertical wind tunnels that simulate the thermal environments encountered in most electronics equipment. This type of equipment commonly uses vertically mounted circuit cards in cabinet racks in which the power modules are mounted.

The following figure shows the wind tunnel characterization setup. The power module is mounted on a test PWB and is vertically positioned within the wind tunnel. The space between the neighboring PWB and the top of the power module is constantly kept at 6.35mm (0.25").

Thermal Derating

Heat can be removed by increasing airflow over the module. To enhance system reliability, the power module should always be operated below the maximum operating temperature. If the temperature exceeds the maximum module temperature, reliability of the unit may be affected.

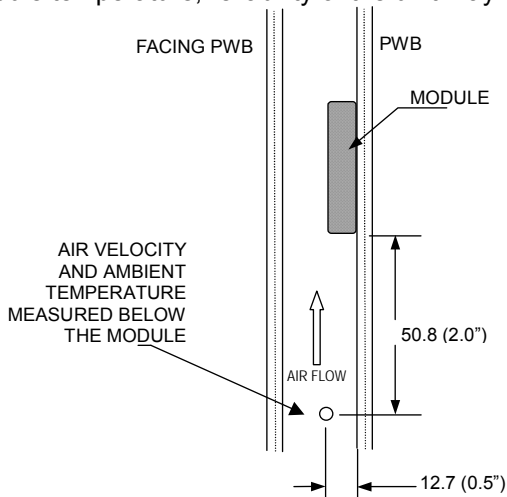

Note: Wind Tunnel Test Setup Figure Dimensions are in millimeters and (Inches)

Figure 19: Wind Tunnel Test Setup

THERMAL CURVES

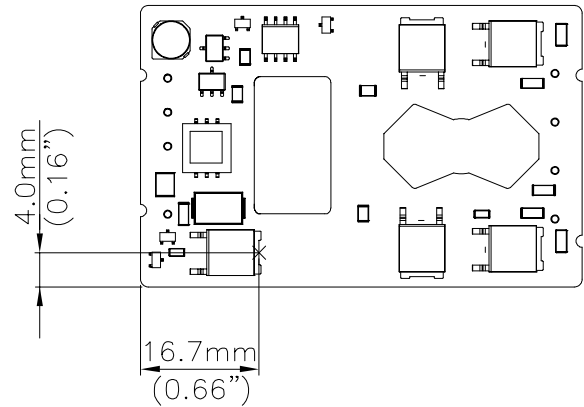

Figure 20: Temperature measurement location

* The allowed maximum hot spot temperature is defined at 124°C

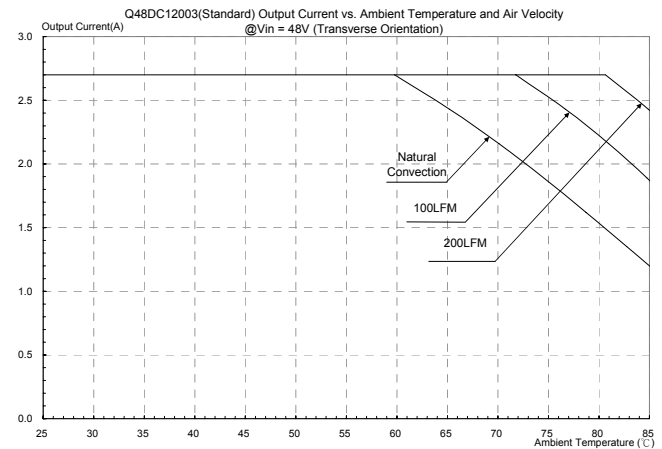
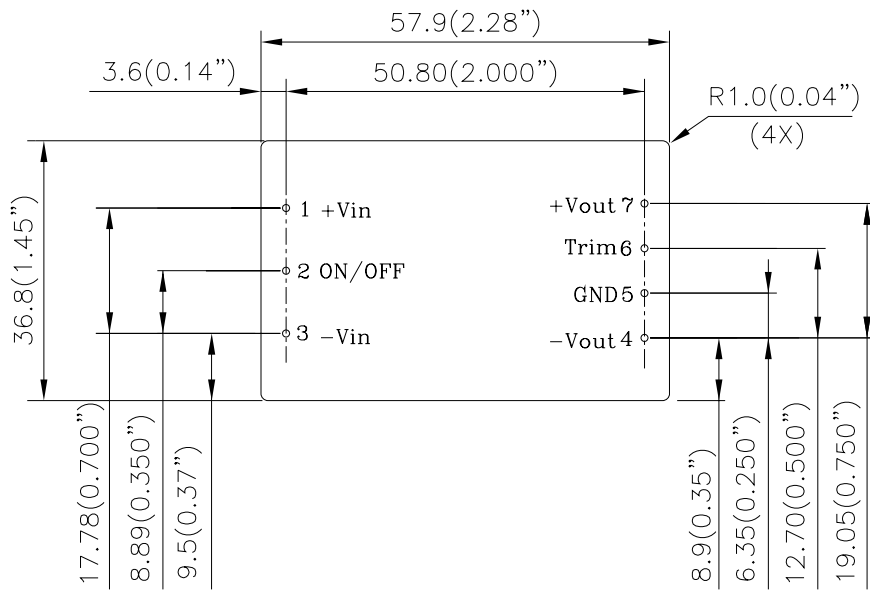
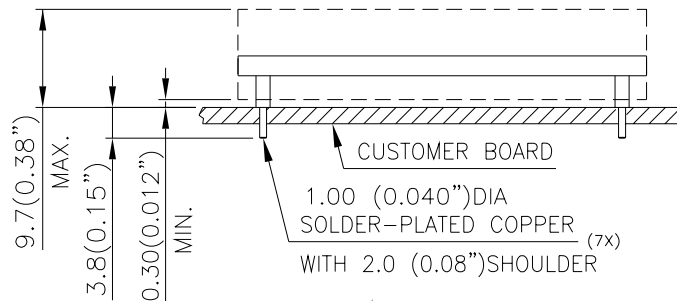

Figure 21: Output current vs. ambient temperature and air velocity @ $V_{in} = 48V$ (Transverse Orientation)

MECHANICAL DRAWING



TOP VIEW



SIDE VIEW

NOTES:

DIMENSIONS ARE IN MILLIMETERS AND (INCHES)

TOLERANCES: X.Xmm±0.5mm(X.XX in.±0.02 in.)

X.XXmm±0.25mm(X.XXX in.±0.010 in.)

ON/OFF: NEGATIVE LOGIC ENABLE(OPEN=OFF,-Vin=ON)

Pin No.	Name	Function
1	+Vin	Positive input voltage
2	ON/OFF	Remote ON/OFF
3	-Vin	Negative input voltage
4	-Vout	Negative output voltage
5	GND	Ground
6	Trim	Output voltage trim
7	+Vout	Positive output voltage

PART NUMBERING SYSTEM

Q	48	D	C	120	03	N	R	F	A
Product Type	Input Voltage	Number of Outputs	Product Series	Output Voltage	Output Current	ON/OFF Logic	Pin Length		Option Code
Q - Quarter Brick	48V	D - Dual Output	C - 2nd generation of bipolar dual output	120 - 12.1V	03 - 2.7A	N - Negative P - Positive	R - 0.150"	F - RoHS 6/6 (Lead Free)	A - Standard Functions

MODEL LIST

MODEL NAME	INPUT		OUTPUT		EFF @ 100% LOAD
Q48DC12003NR A	36V~75V	2.4A	±12.1V	2.7A	88%

CONTACT: www.delta.com.tw/dcdc

USA:

Telephone:
 East Coast: (888) 335 8201
 West Coast: (888) 335 8208
 Fax: (978) 656 3964
 Email: DCDC@delta-corp.com

Europe:

Phone: +41 31 998 53 11
 Fax: +41 31 998 53 53
 Email: DCDC@delta-es.com

Asia & the rest of world:

Telephone: +886 3 4526107 ext 6220
 Fax: +886 3 4513485
 Email: DCDC@delta.com.tw

WARRANTY

Delta offers a two (2) year limited warranty. Complete warranty information is listed on our web site or is available upon request from Delta.

Information furnished by Delta is believed to be accurate and reliable. However, no responsibility is assumed by Delta for its use, nor for any infringements of patents or other rights of third parties, which may result from its use. No license is granted by implication or otherwise under any patent or patent rights of Delta. Delta reserves the right to revise these specifications at any time, without notice.

Free Manuals Download Website

<http://myh66.com>

<http://usermanuals.us>

<http://www.somanuals.com>

<http://www.4manuals.cc>

<http://www.manual-lib.com>

<http://www.404manual.com>

<http://www.luxmanual.com>

<http://aubethermostatmanual.com>

Golf course search by state

<http://golfingnear.com>

Email search by domain

<http://emailbydomain.com>

Auto manuals search

<http://auto.somanuals.com>

TV manuals search

<http://tv.somanuals.com>