

# DELPHI SERIES



## FEATURES

- ♦ High Efficiency 88% @ 1.8V/ 60A
- ♦ Standard footprint: 58.4 x 61.0 x 11.7mm (2.30" x2.40" x0.46")
- ♦ Industry standard pin out
- ♦ Startup into pre-biased load
- ♦ Fixed frequency operation
- ♦ Fully protected: OTP, OVP, OCP, UVLO
- ♦ No minimum load required
- ♦ Wide output trim range
- ♦ Fast transient response
- ♦ Basic insulation
- ♦ ISO 9001, TL 9000, ISO 14001, QS9000, OHSAS18001 certified manufacturing facility
- ♦ UL/cUL 60950 (US & Canada) Recognized, and TUV (EN60950) Certified
- ♦ CE mark meets 73/23/EEC and 93/68/EEC directives

## Delphi Series H48SR, 200W Half Brick Family DC/DC Power Modules: 48V in, 1.8V/60A out

The Delphi Series H48SR Half Brick, 48V input, adjustable single output, isolated, open frame DC/DC converters are the latest offering from a world leader in power systems technology and manufacturing -- Delta Electronics, Inc. This product family provides up to 200 watts of power or up to 80A of output current in an industry standard footprint. This product represents the next generation of design technology which may be utilized to provide high levels of current at very low output voltages required by today's leading-edge circuitry. Utilizing an advanced patented thermal and electrical design technology, the Delphi Series H48SR converters are capable of providing higher output current capability with excellent transient response and lower common mode noise. Featuring a wide operating output voltage range and high current at low output voltages, these units offer more useable power over a wide range of ambient operating conditions. The wide range trimmable output feature allows the user to both reduce and standardize part numbers across different and/or migrating voltage requirements.

## OPTIONS

- ♦ Short lead lengths
- ♦ Latching/non-latching over voltage protection
- ♦ Positive remote on/off
- ♦ 100V/100ms transient capability or 80V input OVLO

## APPLICATIONS

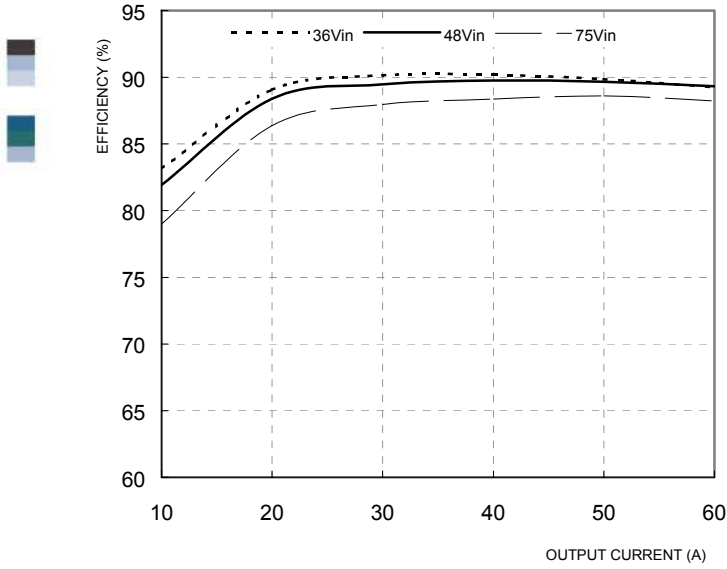
- ♦ Telecom/DataCom
- ♦ Wireless Networks
- ♦ Optical Network Equipment
- ♦ Server and Data Storage
- ♦ Industrial/Test Equipment

# TECHNICAL SPECIFICATIONS

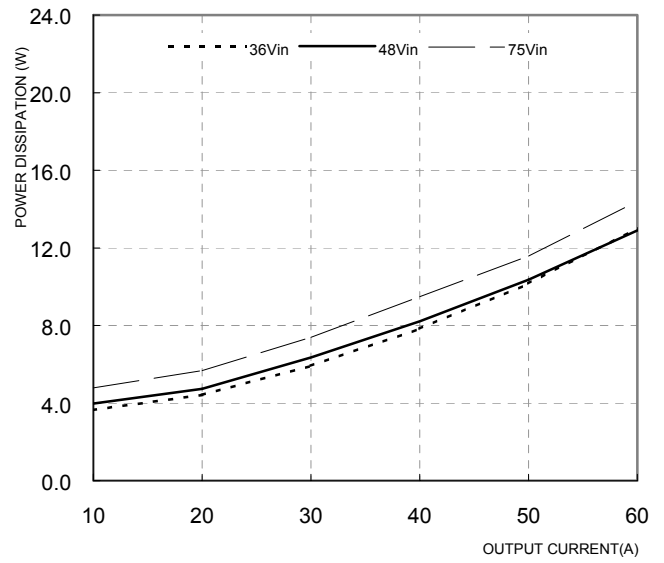
( $T_A=25^{\circ}\text{C}$ , airflow rate=300 LFM,  $V_{in}=48\text{Vdc}$ , nominal  $V_{out}$  unless otherwise noted.)

PARAMETER	NOTES and CONDITIONS	H48SR1R860NRFA			
		Min.	Typ.	Max.	Units
<b>ABSOLUTE MAXIMUM RATINGS</b>					
<b>Input Voltage</b>					
Continuous				80	Vdc
Transient (100ms)	100ms			100	Vdc
Operating Device Temperature	$T_c$	-40		115	$^{\circ}\text{C}$
Storage Temperature		-55		125	$^{\circ}\text{C}$
Input/Output Isolation Voltage	1 minute	1500			Vdc
<b>INPUT CHARACTERISTICS</b>					
Operating Input Voltage		36	48	75	Vdc
Input Under-Voltage Lockout					
Turn-On Voltage Threshold		32.5	34	35	Vdc
Turn-Off Voltage Threshold		31	32	33.5	Vdc
Lockout Hysteresis Voltage		1	2	3	Vdc
Maximum Input Current	100% Load, 36Vin			3.7	A
No-Load Input Current			100	140	mA
Off Converter Input Current			15	25	mA
Inrush Current( $I^2t$ )			0.03		$\text{A}^2\text{S}$
Input Reflected-Ripple Current	P-P thru 12 $\mu\text{H}$ inductor, 5Hz to 20MHz		10		mA
Input Voltage Ripple Rejection	120 Hz		60		dB
<b>OUTPUT CHARACTERISTICS</b>					
Output Voltage Set Point	$V_{in}=48\text{V}$ , $I_o=I_{o,max}$ , $T_c=25^{\circ}\text{C}$	1.75	1.8	1.85	Vdc
Output Voltage Regulation					
Over Load	$I_o=I_{o,min}$ to $I_{o,max}$		$\pm 2$	$\pm 7$	mV
Over Line	$V_{in}=36\text{V}$ to $75\text{V}$		$\pm 2$	$\pm 5$	mV
Over Temperature	$T_c=-40^{\circ}\text{C}$ to $100^{\circ}\text{C}$		$\pm 20$	$\pm 50$	mV
Total Output Voltage Range	over load, line and temperature	TBD		TBD	V
Output Voltage Ripple and Noise	5Hz to 20MHz bandwidth				
Peak-to-Peak	Full Load, 1 $\mu\text{F}$ ceramic, 10 $\mu\text{F}$ tantalum		70	120	mV
RMS	Full Load, 1 $\mu\text{F}$ ceramic, 10 $\mu\text{F}$ tantalum		20	40	mV
Operating Output Current Range		0		60	A
Output DC Current-Limit Inception	Output Voltage 10% Low	105		130	%
<b>DYNAMIC CHARACTERISTICS</b>					
Output Voltage Current Transient	48V, 10 $\mu\text{F}$ Tan & 1 $\mu\text{F}$ Ceramic load cap, 0.1A/ $\mu\text{s}$				
Positive Step Change in Output Current	50% $I_{o,max}$ to 75% $I_{o,max}$		50	100	mV
Negative Step Change in Output Current	75% $I_{o,max}$ to 50% $I_{o,max}$		50	100	mV
Settling Time (within 1% $V_{out}$ nominal)			200		$\mu\text{S}$
Turn-On Transient					
Start-Up Time, From On/Off Control			10	20	mS
Start-Up Time, From Input	$-40^{\circ}\text{C}$ to $+125^{\circ}\text{C}$		20	40	mS
Maximum Output Capacitance	Full load; 5% overshoot of $V_{out}$ at startup			20000	$\mu\text{F}$
<b>EFFICIENCY</b>					
100% Load			88		%
60% Load			88.5		%
<b>ISOLATION CHARACTERISTICS</b>					
Input to Output		1500			Vdc
Isolation Resistance		10			$\text{M}\Omega$
Isolation Capacitance			3000		pF
<b>FEATURE CHARACTERISTICS</b>					
Switching Frequency			240		kHz
ON/OFF Control, (Logic Low-Module ON)					
Logic Low	$V_{on/off}$ at $I_{on/off}=1.0\text{mA}$	0		0.8	V
Logic High	$V_{on/off}$ at $I_{on/off}=0.0\mu\text{A}$			15	V
ON/OFF Current	$I_{on/off}$ at $V_{on/off}=0.0\text{V}$			1	mA
Leakage Current	Logic High, $V_{on/off}=15\text{V}$			50	$\mu\text{A}$
Output Voltage Trim Range	Across Pins 9 & 5, $P_{out} \leq \text{max rated power}$	0.8		1.9	V
Output Voltage Remote Sense Range	$P_{out} \leq \text{max rated power}$			10	%
Output Over-Voltage Protection	Over full temp range; % of nominal $V_{out}$	115	130	155	%
<b>GENERAL SPECIFICATIONS</b>					
MTBF	$I_o=80\%$ of $I_o, \text{max}$ ; $T_a=25^{\circ}\text{C}$ , airflow rate=300 LFM		1.5		M hours
Weight			66		grams
Over-Temperature Shutdown	Power Region Temperature		130		$^{\circ}\text{C}$

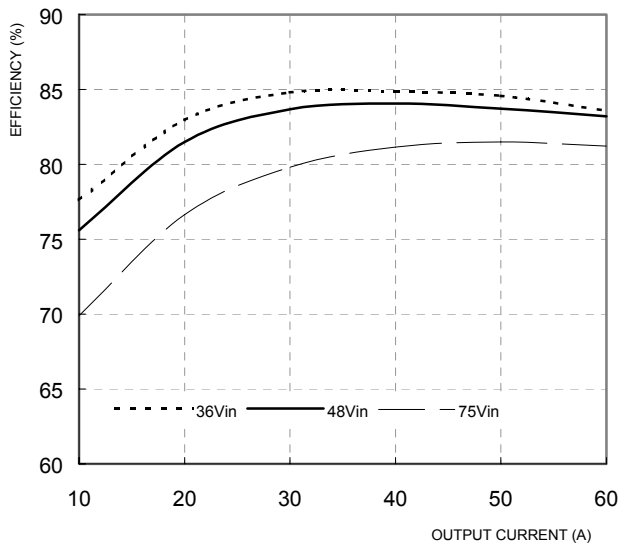
# ELECTRICAL CHARACTERISTICS CURVES



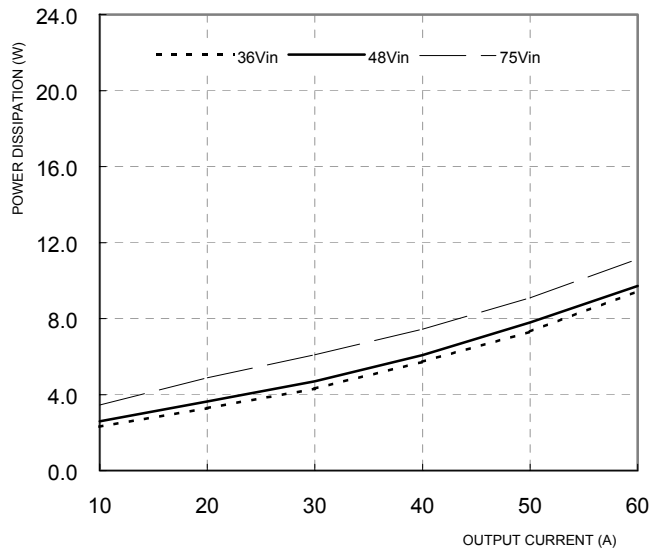
**Figure 1:** Efficiency vs. load current for minimum, nominal, and maximum input voltage at 25°C. (V<sub>out</sub>=1.8V)



**Figure 2:** Power dissipation vs. load current for minimum, nominal, and maximum input voltage at 25°C. (V<sub>out</sub>=1,8V)



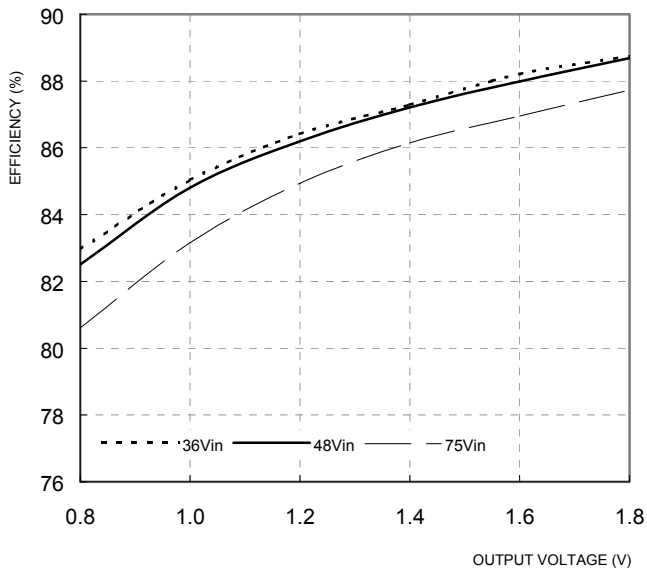
**Figure 3:** Efficiency vs. load current for minimum, nominal, and maximum input voltage at 25°C. (V<sub>out</sub>=0.8V)



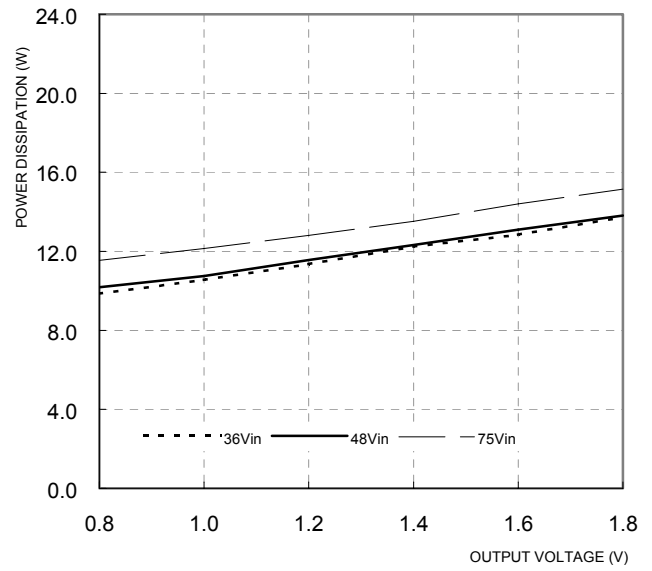
**Figure 4:** Power dissipation vs. load current for minimum, nominal, and maximum input voltage at 25°C. (V<sub>out</sub>=0.8V)



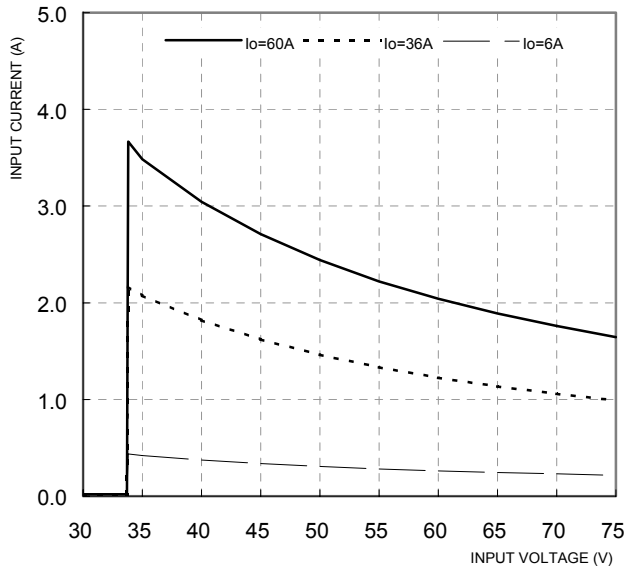
# ELECTRICAL CHARACTERISTICS CURVES



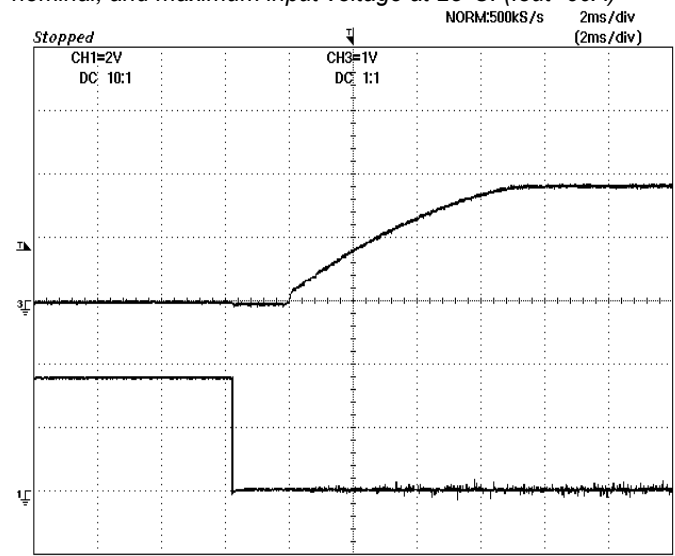
**Figure 5:** Efficiency vs. output voltage for minimum, nominal, and maximum input voltage at 25°C. ( $I_{out}=60A$ )



**Figure 6:** Power dissipation vs. output voltage for minimum, nominal, and maximum input voltage at 25°C. ( $I_{out}=60A$ )

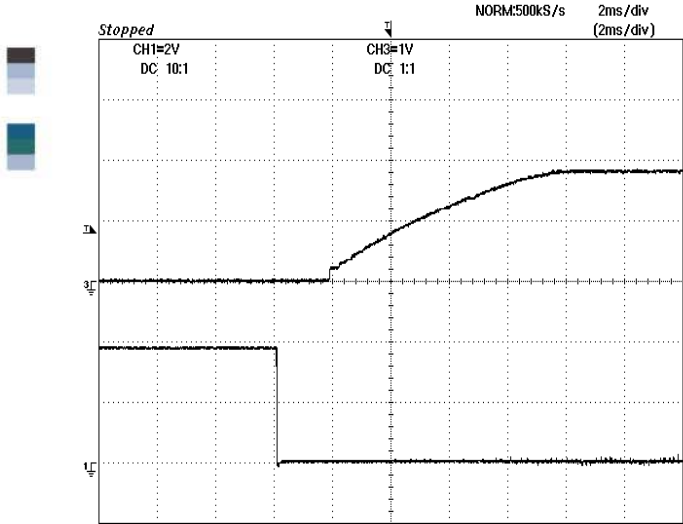


**Figure 7:** Typical input characteristics at room temperature

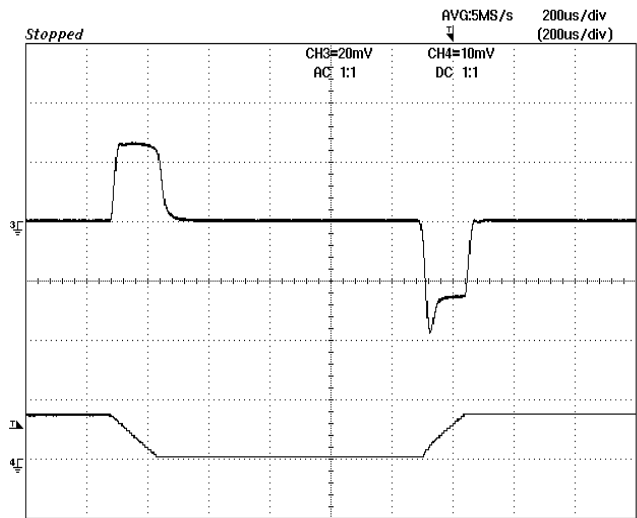


**Figure 8:** Turn-on transient at full rated load current (resistive load) (1 ms/div). Top Trace:  $V_{out}$ ; 1V/div; Bottom Trace: ON/OFF input: 2V/div

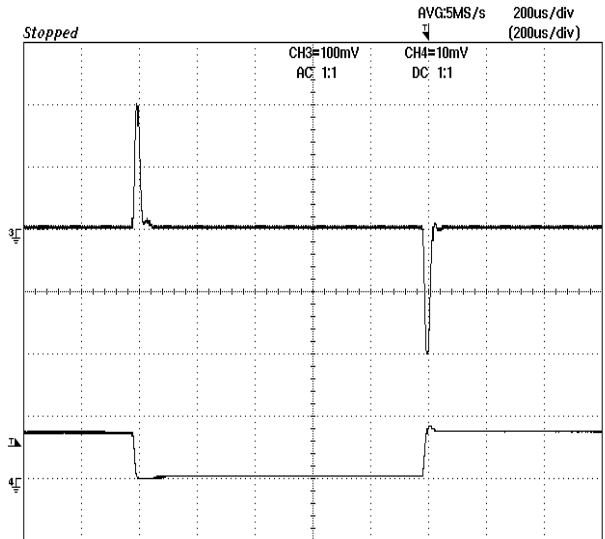
# ELECTRICAL CHARACTERISTICS CURVES



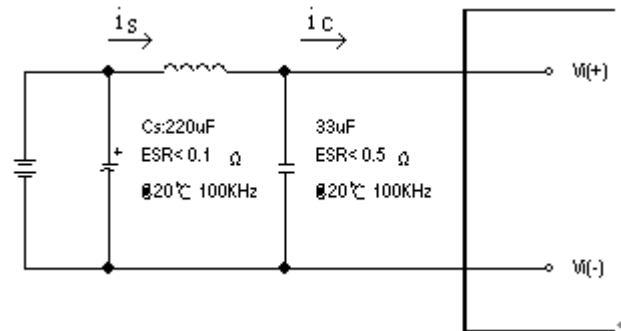
**Figure 9:** Turn-on transient at zero load current (2 ms/div). Top Trace: Vout: 1V/div; Bottom Trace: ON/OFF input: 2V/div



**Figure 10:** Output voltage response to step-change in load current (75%-50%-75% of  $I_o$ , max;  $di/dt = 0.1A/\mu s$ ). Load cap:  $10\mu F$ , tantalum capacitor and  $1\mu F$  ceramic capacitor. Top Trace: Vout (20 mV/div), Bottom Trace: Iout (20A/div). Scope measurement should be made using a BNC cable (length shorter than 20 inches). Position the load between 51 mm to 76 mm (2 inches to 3 inches) from the module..

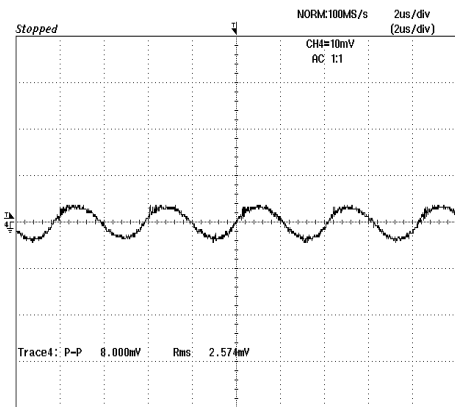


**Figure 11:** Output voltage response to step-change in load current (75%-50%-75% of  $I_o$ , max;  $di/dt = 2.5A/\mu s$ ). Load cap:  $470\mu F$ ,  $35m\Omega$  ESR solid electrolytic capacitor and  $1\mu F$  ceramic capacitor. Top Trace: Vout (100mV/div), Bottom Trace: Iout (20A/div). Scope measurement should be made using a BNC cable (length shorter than 20 inches). Position the load between 51 mm to 76 mm (2 inches to 3 inches) from the module.

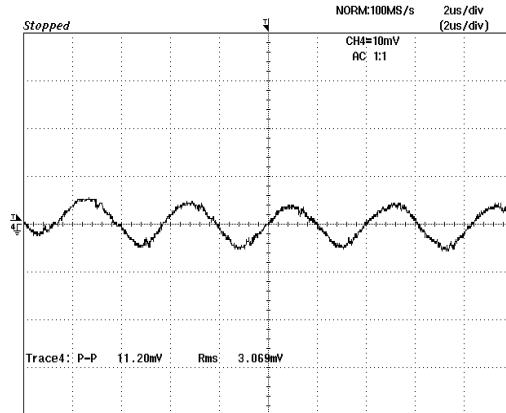


**Figure 12:** Test set-up diagram showing measurement points for Input Terminal Ripple Current and Input Reflected Ripple Current. Note: Measured input reflected-ripple current with a simulated source Inductance ( $L_{TEST}$ ) of  $12\mu H$ . Capacitor  $C_s$  offset possible battery impedance. Measure current as shown above.

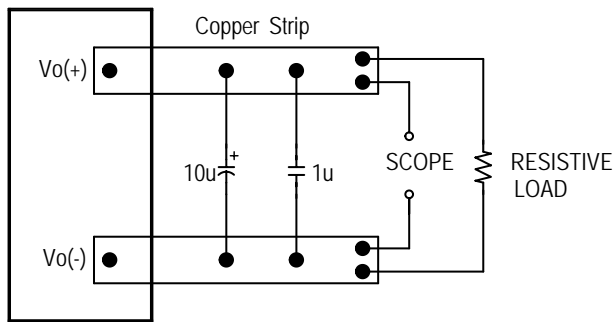
# ELECTRICAL CHARACTERISTICS CURVES



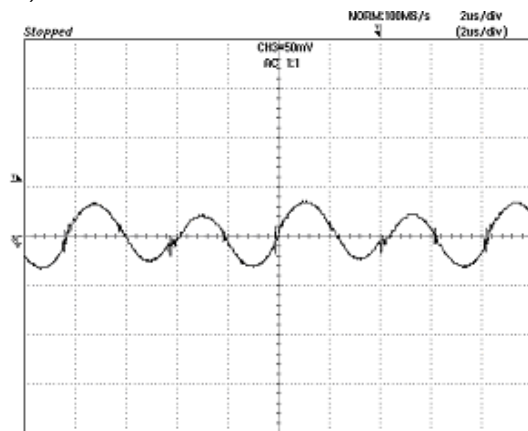
**Figure 13:** Input Terminal Ripple Current,  $i_c$ , at full rated output current and nominal input voltage with  $12\mu\text{H}$  source impedance and  $33\mu\text{F}$  electrolytic capacitor ( $500\text{ mA/div}$ ).



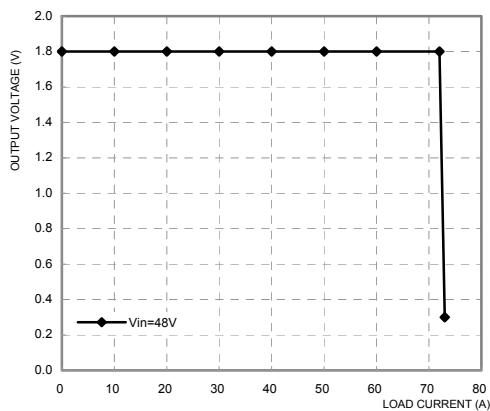
**Figure 14:** Input reflected ripple current,  $i_s$ , through a  $12\mu\text{H}$  source inductor at nominal input voltage and rated load current ( $5\text{ mA/div}$ ).



**Figure 15:** Output voltage noise and ripple measurement test setup



**Figure 16:** Output voltage ripple at nominal input voltage and rated load current ( $50\text{ mV/div}$ ). Load capacitance:  $1\mu\text{F}$  ceramic capacitor and  $10\mu\text{F}$  tantalum capacitor. Bandwidth:  $20\text{ MHz}$ . Scope measurement should be made using a BNC cable (length shorter than  $20\text{ inches}$ ). Position the load between  $51\text{ mm}$  to  $76\text{ mm}$  ( $2\text{ inches}$  to  $3\text{ inches}$ ) from the module.



**Figure 17:** Output voltage vs. load current showing typical current limit curves and converter shutdown points.

# THERMAL CURVES

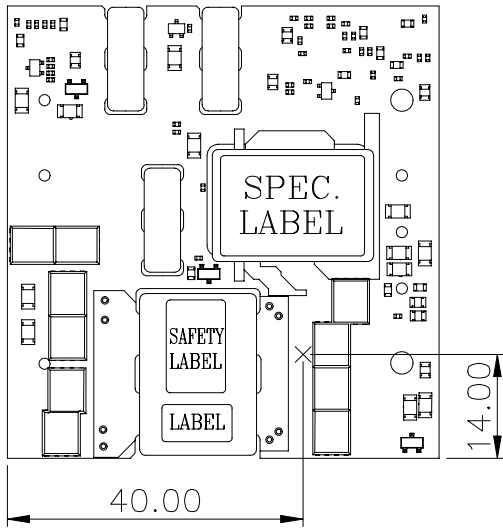


Figure 18: Hot spot location (unit in mm)

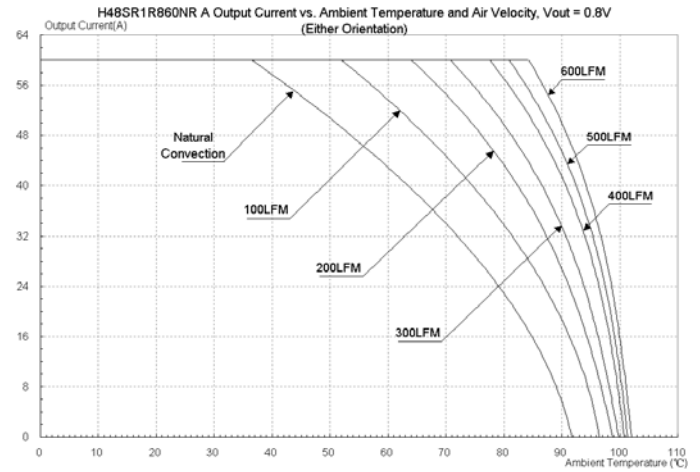


Figure 19: Output current vs. ambient temperature and air velocity ( $V_{in}=48V / 75V$ ,  $V_{out}=0.8V$ )

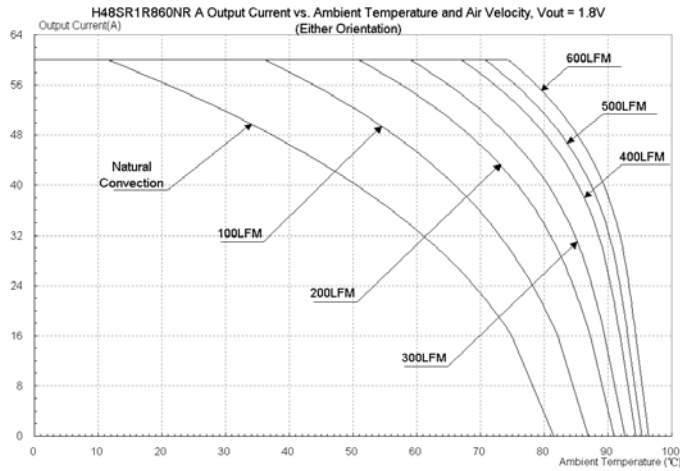


Figure 20: Output current vs. ambient temperature and air velocity ( $V_{in}=48V / 75V$ ,  $V_{out}=1.8V$ )

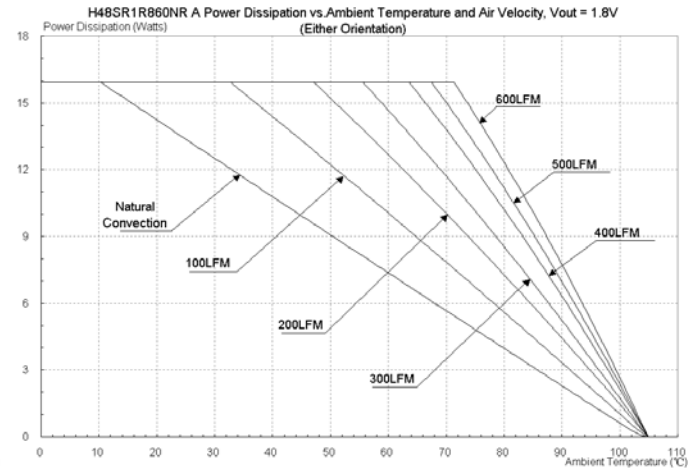


Figure 21: Power dissipation vs. ambient temperature and air velocity ( $V_{in}=48V / 75V$ ,  $V_{out}=0.8V \sim 1.8V$ )

## DESIGN CONSIDERATIONS

### Input Source Impedance

The impedance of the input source connecting to the DC/DC power modules will interact with the modules and affect the stability. A low ac-impedance input source is recommended. If the source inductance is more than a few  $\mu\text{H}$ , we advise adding a 10 to 100  $\mu\text{F}$  electrolytic capacitor ( $\text{ESR} < 0.7 \Omega$  at 100 kHz) mounted close to the input of the module to improve the stability.

### Layout and EMC Considerations

Delta's DC/DC power modules are designed to operate in a wide variety of systems and applications. For design assistance with EMC compliance and related PWB layout issues, please contact Delta's technical support team. An external input filter module is available for easier EMC compliance design. Application notes to assist designers in addressing these issues are pending release.

### Safety Considerations

The power module must be installed in compliance with the spacing and separation requirements of the end-user's safety agency standard, i.e., UL60950, CAN/CSA-C22.2 No. 60950-00 and EN60950:2000 and IEC60950-1999, if the system in which the power module is to be used must meet safety agency requirements.

When the input source is 60 Vdc or below, the power module meets SELV (safety extra-low voltage) requirements. If the input source is a hazardous voltage which is greater than 60 Vdc and less than or equal to 75 Vdc, for the module's output to meet SELV requirements, all of the following must be met:

- The input source must be insulated from any hazardous voltages, including the ac mains, with reinforced insulation.
- One  $V_i$  pin and one  $V_o$  pin are grounded, or all the input and output pins are kept floating.
- The input terminals of the module are not operator accessible.
- If the metal baseplate is grounded the output must be also grounded.
- A SELV reliability test is conducted on the system where the module is used to ensure that under a single fault, hazardous voltage does not appear at the module's output.

Do not ground one of the input pins without grounding one of the output pins. This connection may allow a non-SELV voltage to appear between the output pin and ground.

The power module has extra-low voltage (ELV) outputs when all inputs are ELV.

This power module is not internally fused. To achieve optimum safety and system protection, an input line fuse is highly recommended. The safety agencies require a normal-blow fuse with 20A maximum rating to be installed in the ungrounded lead. A lower rated fuse can be used based on the maximum inrush transient energy and maximum input current.

### Soldering and Cleaning Considerations

Post solder cleaning is usually the final board assembly process before the board or system undergoes electrical testing. Inadequate cleaning and/or drying may lower the reliability of a power module and severely affect the finished circuit board assembly test. Adequate cleaning and/or drying is especially important for un-encapsulated and/or open frame type power modules. For assistance on appropriate soldering and cleaning procedures, please contact Delta's technical support team.



## FEATURES DESCRIPTIONS

### Over-Current Protection

The modules include an internal output over-current protection circuit, which will endure current limiting for an unlimited duration during output overload. If the output current exceeds the OCP set point, the modules will automatically shut down (hiccup mode).

The modules will try to restart after shutdown. If the overload condition still exists, the module will shut down again. This restart trial will continue until the overload condition is corrected.

### Over-Voltage Protection

The modules include an internal output over-voltage protection circuit, which monitors the voltage on the output terminals. If this voltage exceeds the over-voltage set point, the module will shut down and latch off. The over-voltage latch is reset by cycling the input power for one second.

### Over-Temperature Protection

The over-temperature protection consists of circuitry that provides protection from thermal damage. If the temperature exceeds the over-temperature threshold the module will shut down.

The module will try to restart after shutdown. If the over-temperature condition still exists during restart, the module will shut down again. This restart trial will continue until the temperature is within specification.

### Remote On/Off

The remote on/off feature on the module can be either negative or positive logic. Negative logic turns the module on during a logic low and off during a logic high. Positive logic turns the modules on during a logic high and off during a logic low.

Remote on/off can be controlled by an external switch between the on/off terminal and the Vi(-) terminal. The switch can be an open collector or open drain.

For negative logic if the remote on/off feature is not used, please short the on/off pin to Vi(-). For positive logic if the remote on/off feature is not used, please leave the on/off pin floating.

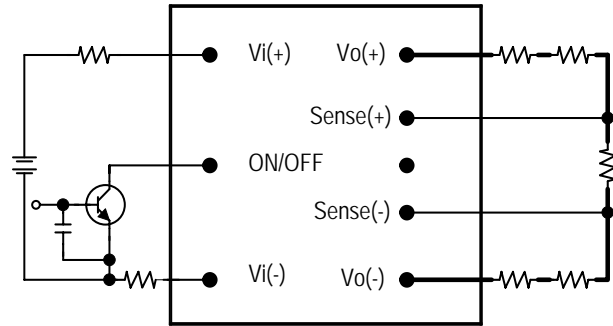


Figure 22: Remote on/off implementation

### Remote Sense

Remote sense compensates for voltage drops on the output by sensing the actual output voltage at the point of load. The voltage between the remote sense pins and the output terminals must not exceed the output voltage sense range given here:

$$[Vo(+) - Vo(-)] - [SENSE(+) - SENSE(-)] \leq 10\% \times V_{out}$$

This limit includes any increase in voltage due to remote sense compensation and output voltage set point adjustment (trim).

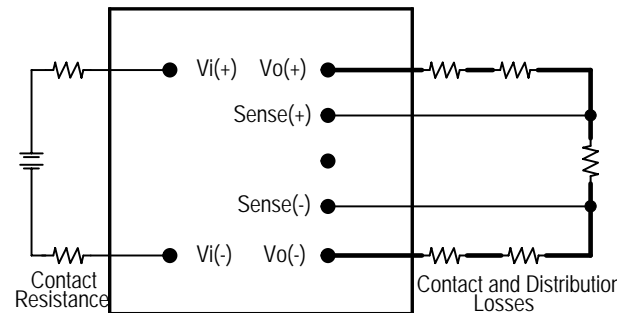


Figure 23: Effective circuit configuration for remote sense operation

If the remote sense feature is not used to regulate the output at the point of load, please connect SENSE(+) to Vo(+) and SENSE(-) to Vo(-) at the module.

The output voltage can be increased by both the remote sense and the trim; however, the maximum increase is the larger of either the remote sense or the trim, not the sum of both.

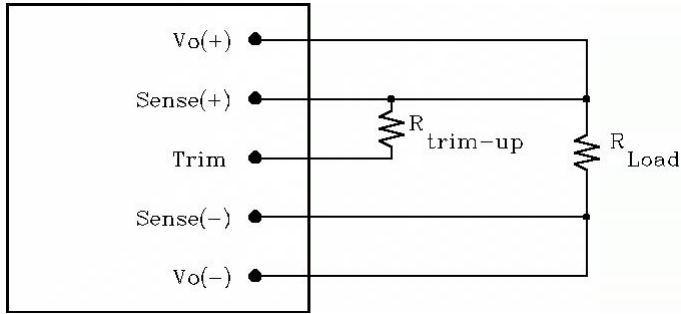
When using remote sense and trim, the output voltage of the module is usually increased, which increases the power output of the module with the same output current.

Care should be taken to ensure that the maximum output power does not exceed the maximum rated power.

## FEATURES DESCRIPTIONS (CON.)

### Output Voltage Adjustment (TRIM)

To increase or decrease the output voltage set point, the modules may be connected with an external resistor between the TRIM pin and either the SENSE(+) or SENSE(-). The TRIM pin should be left open if this feature is not used.



**Figure 23:** Circuit configuration for trim-up (increase output voltage)

If the external resistor is connected between the TRIM and SENSE (+) pins, the output voltage set point increases (Fig. 23). The external resistor value required to obtain a percentage of output voltage change  $\Delta\%$  is defined as:

$$R_{trim-up}(\Delta) = \left[ \frac{V_{onom}(1 + \Delta) - V_{ref}}{V_{ref}\Delta} \right] 10k\Omega - 11k\Omega$$

where

$V_{onom}$  = nominal  $V_{out}$  (1.8V)

$V_{ref}$  = 1.225V

$\Delta$  = trim expressed as decimal fraction, i.e. 10% is written as 0.1

Ex. When trim up to 1.9V from 1.8V

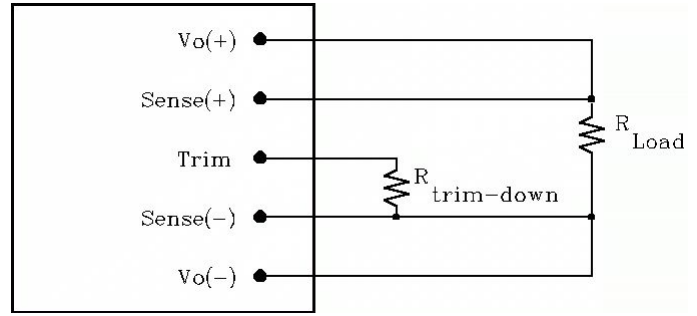
$V_{onom}$  = 1.8V

$V_{ref}$  = 1.225V

$\Delta = (1.9-1.8)/1.8 = 0.05556$

$$R_{trim-up} = \frac{[(1.8 * (1.05556)) - 1.225]}{1.225 * 0.05556} \times 10K\Omega$$

$$- 11K\Omega = 88.18K\Omega$$



**Figure 24:** Circuit configuration for trim-down (decrease output voltage)

If the external resistor is connected between the TRIM and SENSE (-) the output voltage set point decreases (Fig. 24). The external resistor value required to obtain a percentage output voltage change  $\Delta\%$  is defined as:

$$R_{trim-down}(\Delta) = \frac{10k\Omega}{\Delta} - 11k\Omega$$

where

$V_{onom}$  = nominal  $V_{out}$  (1.8V)

$\Delta$  = trim expressed as decimal fraction, i.e. 40% is written as 0.4

Ex. When trim down to 0.8V from 1.8V

$V_{onom}$  = 1.8V

$\Delta = (1.8-0.8)/1.8 = 0.5556$

$$R_{trim-down} = \frac{10K}{0.5556} - 11K\Omega = 7K\Omega$$

The output voltage can be increased by both the remote sense and the trim, however the maximum increase is the larger of either the remote sense or the trim, not the sum of both.

When using remote sense and trim, the output voltage of the module is usually increased, which increases the power output of the module with the same output current.

Care should be taken to ensure that the maximum output power of the module remains at or below the maximum rated power.

Output voltage	Resistor value ( $k\Omega$ )
1.5V	49.00
1.2V	19.00
1.0V	11.50
0.9V	9.0
0.8V	7.0

**Figure 25:** Trim resistor value example for popular output voltages. Connect the resistor between the TRIM and SENSE (-) pins.

## THERMAL CONSIDERATIONS

Thermal management is an important part of the system design. To ensure proper, reliable operation, sufficient cooling of the power module is needed over the entire temperature range of the module. Convection cooling is usually the dominant mode of heat transfer.

Hence, the choice of equipment to characterize the thermal performance of the power module is a wind tunnel.

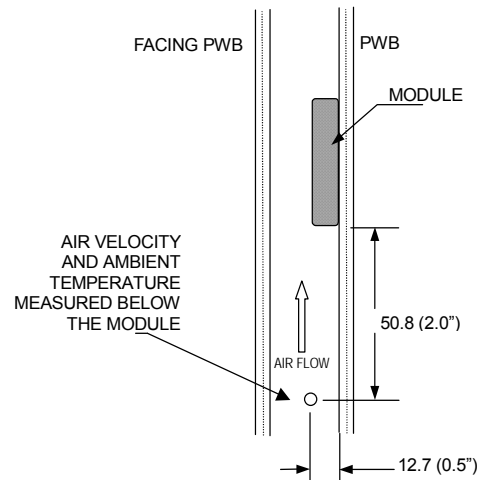
### Thermal Testing Setup

Delta's DC/DC power modules are characterized in heated vertical wind tunnels that simulate the thermal environments encountered in most electronics equipment. This type of equipment commonly uses vertically mounted circuit cards in cabinet racks in which the power modules are mounted.

The following figure shows the wind tunnel characterization setup. The power module is mounted on a test PWB and is vertically positioned within the wind tunnel. The space between the neighboring PWB and the top of the power module is constantly kept at 6.35mm (0.25").

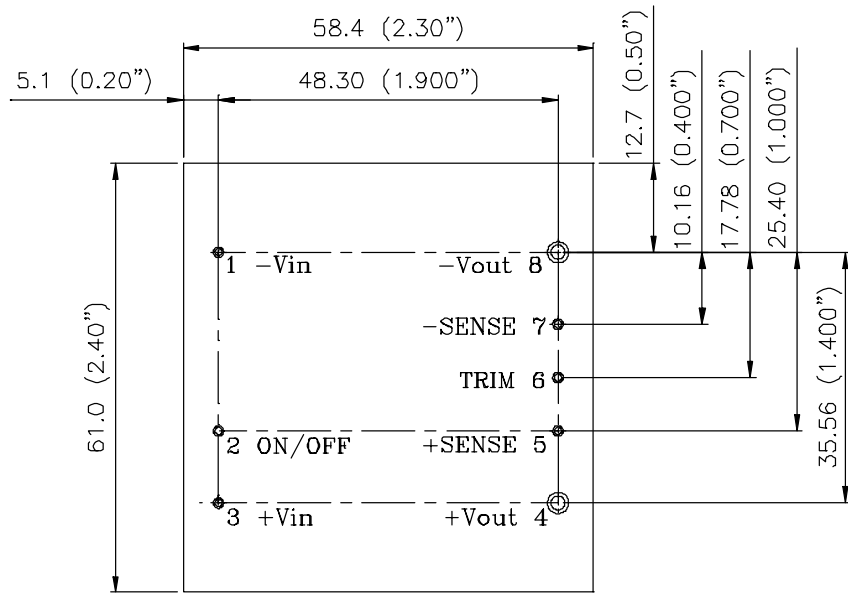
### Thermal Derating

Heat can be removed by increasing airflow over the module. The module's maximum device temperature is 115°C and the measured location is illustrated in Figure 18. To enhance system reliability, the power module should always be operated below the maximum operating temperature. If the temperature exceeds the maximum module temperature, reliability of the unit may be affected.

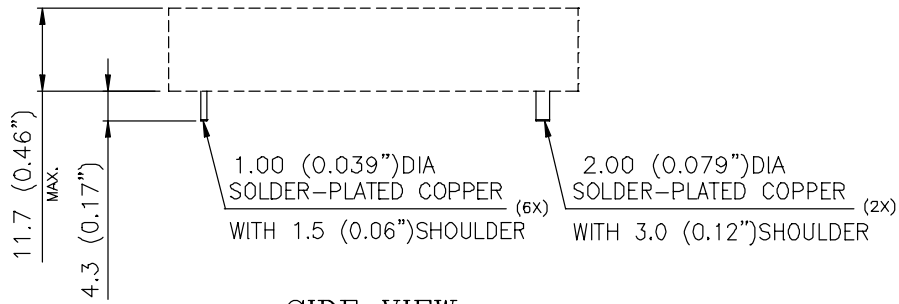


Note: Wind Tunnel Test Setup Figure Dimensions are in millimeters and (Inches)  
**Figure 26: Wind Tunnel Test Setup**

# MECHANICAL DRAWING



**BOTTOM VIEW**



**SIDE VIEW**

**NOTES:**

DIMENSIONS ARE IN MILLIMETERS AND (INCHES)  
 TOLERANCES: X.Xmm±0.5mm(X.XX in.±0.02 in.)  
 X.XXmm±0.25mm(X.XXX in.±0.010 in.)

Pin No.	Name	Function
1	-Vin	Negative input voltage
2	ON/OFF	Remote ON/OFF
3	+Vin	Positive input voltage
4	+Vout	Positive output voltage
5	+SENSE	Positive remote sense
6	TRIM	Output voltage trim
7	-SENSE	Negative remote sense
8	-Vout	Negative output voltage

**Notes:**

- 1 Pins 1-3, 5-7 are 1.00mm (0.039") diameter
- 2 Pins 4 and 8 are 2.00mm (0.079") diameter
- 3 All pins are copper with Tin plating.

## PART NUMBERING SYSTEM

H	48	S	R	1R8	60	N	R	F	A
Form Factor	Input Voltage	Number of Outputs	Product Series	Output Voltage	Output Current	ON/OFF Logic	Pin Length		Option Code
H - Half-Brick	48-36V~75V	S- Single	R- Single Board	1R8- 1.8V	60- 60A 80- 80A	N-Negative P-Positive	R-0.170" N-0.145" K-0.110"	F- RoHS 6/6 (Lead Free)	A - Standard Functions

## MODEL LIST

Part Number	INPUT		OUTPUT		EFF @ 100% LOAD
H48SR1R860NRFA	36V~75V	3.7A	0.8V – 1.9V	60A	88%
H48SR1R880NRFA	36V~75V	5.0A	0.8V – 1.9V	80A	89%
H48SR3R360NRFA	36V~75V	6.4A	1.45V – 3.6V	60A	90%

Please contact us for modules with fixed output voltages.

### CONTACT: [www.delta.com.tw/dcdc](http://www.delta.com.tw/dcdc)

**USA:**  
 Telephone:  
 East Coast: (888) 335 8201  
 West Coast: (888) 335 8208  
 Fax: (978) 656 3964  
 Email: [DCDC@delta-corp.com](mailto:DCDC@delta-corp.com)

**Europe:**  
 Telephone: +41 31 998 53 11  
 Fax: +41 31 998 53 53  
 Email: [DCDC@delta-es.tw](mailto:DCDC@delta-es.tw)

**Asia & the rest of world:**  
 Telephone: +886 3 4526107 x6220  
 Fax: +886 3 4513485  
 Email: [DCDC@delta.com.tw](mailto:DCDC@delta.com.tw)

### WARRANTY

Delta offers a two (2) year limited warranty. Complete warranty information is listed on our web site or is available upon request from Delta.

Information furnished by Delta is believed to be accurate and reliable. However, no responsibility is assumed by Delta for its use, nor for any infringements of patents or other rights of third parties, which may result from its use. No license is granted by implication or otherwise under any patent or patent rights of Delta. Delta reserves the right to revise these specifications at any time, without notice.

## Free Manuals Download Website

<http://myh66.com>

<http://usermanuals.us>

<http://www.somanuals.com>

<http://www.4manuals.cc>

<http://www.manual-lib.com>

<http://www.404manual.com>

<http://www.luxmanual.com>

<http://aubethermostatmanual.com>

Golf course search by state

<http://golfingnear.com>

Email search by domain

<http://emailbydomain.com>

Auto manuals search

<http://auto.somanuals.com>

TV manuals search

<http://tv.somanuals.com>