

14" Wood Cutting Band Saw (Model 28-275C)

INSTRUCTION MANUAL

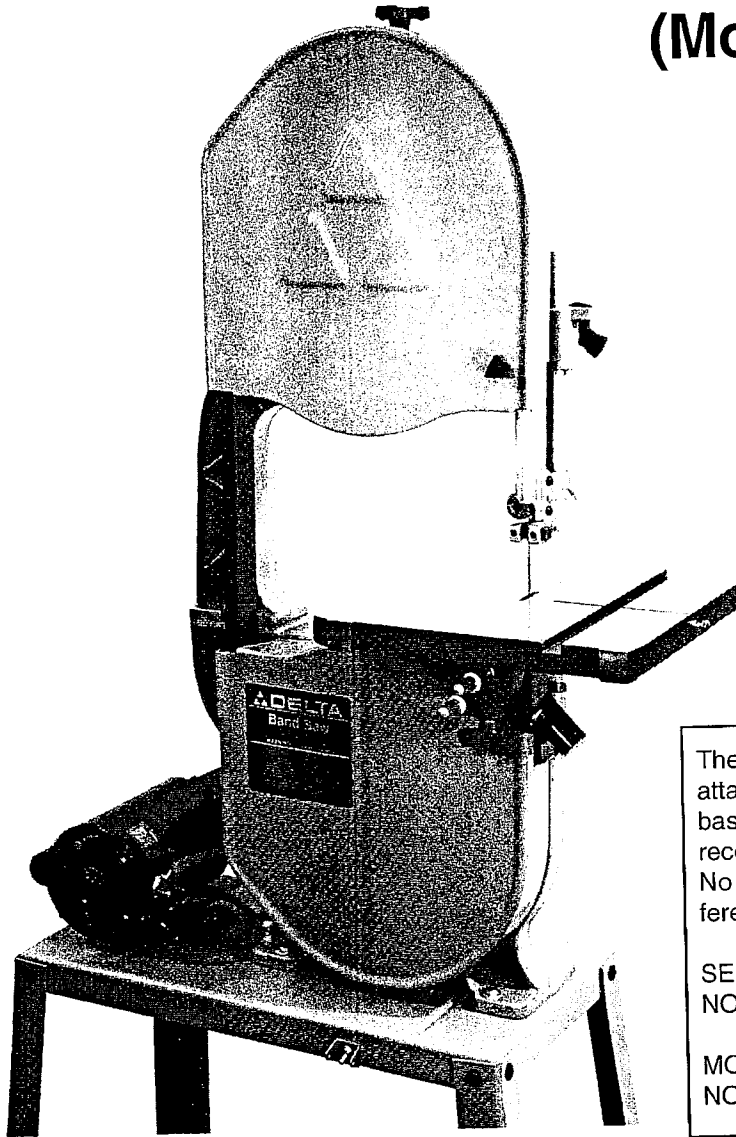

The Serial No. / Model No. plate is attached to the right side of the base casting. Locate this plate and record the Serial No. and Model No. in your manual for future reference.

SERIAL
NO. _____

MODEL
NO. _____

DATED 9-11-95

PART NO. 1233105

© Delta International Machinery Corp. 1995

When it's Delta,
we back it . . .

All the Way!

If you have any problems with your new Delta Power Tool, please call us toll free. Have your model and serial numbers ready.

DELTA

1-800-GO-DELTA(463-3582)

Français au verso

Woodworking can be dangerous if safe and proper operating procedures are not followed. As with all machinery, there are certain hazards involved with the operation of the product. Using the machine with respect and caution will considerably lessen the possibility of personal injury. However, if normal safety precautions are overlooked or ignored, personal injury to the operator may result. Safety equipment such as guards, push sticks, hold-downs, featherboards, goggles, dust masks and hearing protection can reduce your potential for injury. But even the best guard won't make up for poor judgment, carelessness or inattention. Always use common sense and exercise caution in the workshop. If a procedure feels dangerous, don't try it. Figure out an alternative procedure that feels safer. REMEMBER: Your personal safety is your responsibility.

This machine was designed for certain applications only. Delta Machinery strongly recommends that this machine not be modified and/or used for any application other than that for which it was designed. If you have any questions relative to a particular application, DO NOT use the machine until you have first contacted Delta to determine if it can or should be performed on the product.

DELTA INTERNATIONAL MACHINERY CORP.
MANAGER OF TECHNICAL SERVICES
246 ALPHA DRIVE
PITTSBURGH, PENNSYLVANIA 15238
(IN CANADA: 644 IMPERIAL ROAD, GUELPH, ONTARIO N1H 6M7)

WARNING: FAILURE TO FOLLOW THESE RULES MAY RESULT IN SERIOUS PERSONAL INJURY

- 1. FOR YOUR OWN SAFETY, READ INSTRUCTION MANUAL BEFORE OPERATING THE TOOL.** Learn the tool's application and limitations as well as the specific hazards peculiar to it.
- 2. KEEP GUARDS IN PLACE** and in working order.
- 3. ALWAYS WEAR EYE PROTECTION.**
- 4. GROUND ALL TOOLS.** If tool is equipped with three-prong plug, it should be plugged into a three-hole electrical receptacle. If an adapter is used to accommodate a two-prong receptacle, the adapter lug must be attached to a known ground. Never remove the third prong.
- 5. REMOVE ADJUSTING KEYS AND WRENCHES.** Form habit of checking to see that keys and adjusting wrenches are removed from tool before turning it "on."
- 6. KEEP WORK AREA CLEAN.** Cluttered areas and benches invite accidents.
- 7. DON'T USE IN DANGEROUS ENVIRONMENT.** Don't use power tools in damp or wet locations, or expose them to rain. Keep work area well-lighted.
- 8. KEEP CHILDREN AND VISITORS AWAY.** All children and visitors should be kept a safe distance from work area.
- 9. MAKE WORKSHOP CHILDPROOF** - with padlocks, master switches, or by removing starter keys.
- 10. DON'T FORCE TOOL.** It will do the job better and be safer at the rate for which it was designed.
- 11. USE RIGHT TOOL.** Don't force tool or attachment to do a job for which it was not designed.
- 12. WEAR PROPER APPAREL.** No loose clothing, gloves, neckties, rings, bracelets, or other jewelry to get caught in moving parts. Nonslip footwear is recommended. Wear protective hair covering to contain long hair.
- 13. ALWAYS USE SAFETY GLASSES.** Wear safety glasses (must comply with ANSI Z87.1). Everyday eyeglasses only have impact resistant lenses; they are not safety glasses. Also use face or dust mask if cutting operation is dusty.
- 14. SECURE WORK.** Use clamps or a vise to hold work when practical. It's safer than using your hand and frees both hands to operate tool.
- 15. DON'T OVERREACH.** Keep proper footing and balance at all times.
- 16. MAINTAIN TOOLS IN TOP CONDITION.** Keep tools sharp and clean for best and safest performance. Follow instructions for lubricating and changing accessories.
- 17. DISCONNECT TOOLS** before servicing and when changing accessories such as blades, bits, cutters, etc.
- 18. USE RECOMMENDED ACCESSORIES.** The use of accessories and attachments not recommended by Delta may cause hazards or risk of injury to persons.
- 19. REDUCE THE RISK OF UNINTENTIONAL STARTING.** Make sure switch is in "OFF" position before plugging in power cord.
- 20. NEVER STAND ON TOOL.** Serious injury could occur if the tool is tipped or if the cutting tool is accidentally contacted.
- 21. CHECK DAMAGED PARTS.** Before further use of the tool, a guard or other part that is damaged should be carefully checked to ensure that it will operate properly and perform its intended function - check for alignment of moving parts, binding of moving parts, breakage of parts, mounting, and any other conditions that may affect its operation. A guard or other part that is damaged should be properly repaired or replaced.
- 22. DIRECTION OF FEED.** Feed work into a blade or cutter against the direction of rotation of the blade or cutter only.
- 23. NEVER LEAVE TOOL RUNNING UNATTENDED. TURN POWER OFF.** Don't leave tool until it comes to a complete stop.
- 24. DRUGS, ALCOHOL, MEDICATION.** Do not operate tool while under the influence of drugs, alcohol or any medication.
- 25. MAKE SURE TOOL IS DISCONNECTED FROM POWER SUPPLY** while motor is being mounted, connected or reconnected.
- 26. WARNING:** The dust generated by certain woods and wood products can be injurious to your health. Always operate machinery in well ventilated areas and provide for proper dust removal. Use wood dust collection systems whenever possible.

ADDITIONAL SAFETY RULES FOR BAND SAWS

- 1. ADJUST** the upper guide about 1/8" above the material being cut.
- 2. MAKE SURE** that blade tension and blade tracking are properly adjusted.
- 3. STOP** the machine before removing scrap pieces from the table.
- 4. ALWAYS** keep hands and fingers away from blade.
- 5. CHECK** for proper blade size and type.
- 6. DO NOT** attempt to saw stock that does not have a flat surface, unless a suitable support is used.
- 7. HOLD** material firmly and feed into blade at a moderate speed.
- 8. TURN OFF** machine if the material is to be backed out of an uncompleted cut.
- 9. MAKE** "release" cuts before cutting long curves.
- 10. ADDITIONAL INFORMATION** regarding the safe and proper operation of this product is available from the National Safety Council, 1121 Spring Lake Drive, Itasca, IL 60143-3201 in the Accident Prevention Manual for Industrial Operations and also in the Safety Data Sheets provided by the NSC. Please also refer to the American National Standards Institute ANSI 01.1 Safety Requirements for Woodworking Machinery and the U.S. Department of Labor OSHA 1910.213 Regulations.

Carefully unpack the band saw, stand, and all loose items from the cartons. Remove the protective coating from the machined surfaces of the band saw. This coating may be removed with a soft cloth moistened with kerosene (do not use acetone, gasoline or lacquer thinner for this purpose.) After cleaning, cover all unpainted surfaces with a good quality paste wax.

FOR ASSEMBLY

Your band saw can be assembled using a few basic hand tools including:

Screwdriver	1/2" Wrench
Phillips screwdriver	9/16" Wrench
7/16" Wrench	Hex Key (Allen) Wrench

ASSEMBLING STAND

1. Assemble the stand as shown in Fig. 2, using the 24 carriage bolts, 8 flat washers, 8 lockwashers and 24 hex nuts. **NOTE:** When fastening the legs (C) Fig. 2, to the shelf (E), use 8 carriage bolts (F), 8 flat washers, 8 lockwashers and 8 hex nuts. When fastening the tie bars (G) to the legs (C), use 16 carriage bolts (H) and hex nuts. Do not completely tighten the stand hardware at this time.

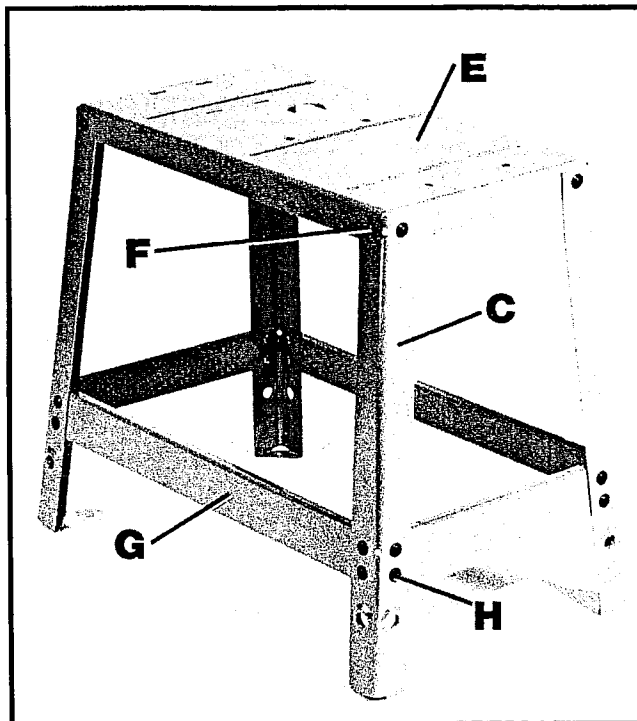

Fig. 2

2. Fig. 3, illustrates the top shelf of the stand. The four holes (A) are for mounting the band saw to the stand. The four holes (B) are for mounting the motor to the stand. If you are using the 62-158 motor, the cord from the motor to the power supply and the cord from the motor to the switch are to be passed through the large hole (D) Fig. 3.

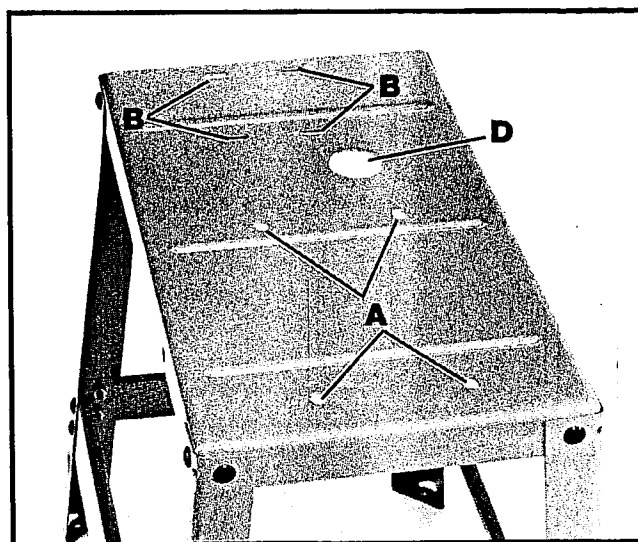

Fig. 3

ASSEMBLING BAND SAW TO STAND

The correct holes in the top shelf of the stand for mounting the band saw are shown at (A) Fig. 3. Assemble the band saw to the stand, as shown in Fig. 4, using the four 5/16-18 x 1-3/4" hex head screws, 5/16" flat washers, 5/16" lockwashers and 5/16"-18 hex nuts. The hex nuts and lockwashers will be located on the underside of the top shelf. Push down on top of stand so the legs of stand adjust to the surface of the floor and tighten all stand hardware.

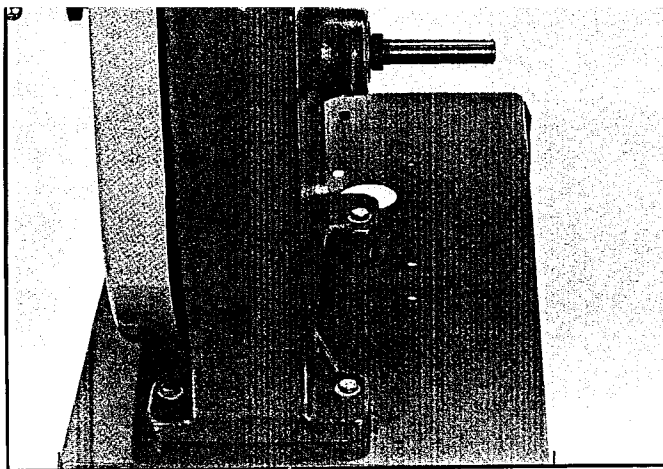

Fig. 4

ASSEMBLING MOTOR TO STAND

The correct holes in the top shelf of the stand for mounting the motor are shown at (B) Fig. 3. Assemble the motor to the stand using four 5/16" x 3/4 inch-long carriage bolts (A) Fig. 5, through the motor plate (B) and stand (C). Fasten the motor to the stand as shown in Fig. 5, from underneath, using four external tooth washers (D), four lockwashers (E) and four hex nuts (F). **NOTE:** Do not completely tighten the motor to the stand at this time as proper belt tension and pulley alignment must first be made.

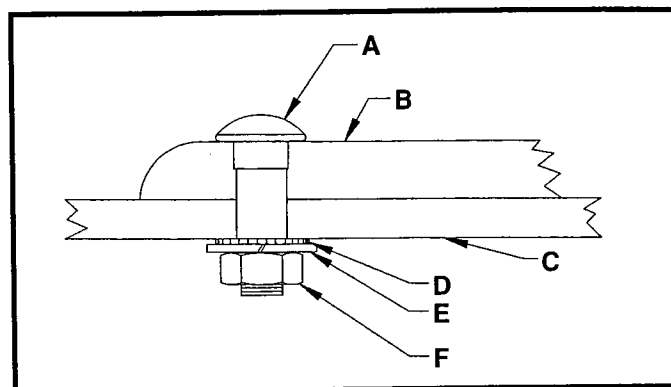

Fig. 5

Place grommet (G) in large hole in top shelf as shown in Fig. 6. **IMPORTANT:** If you are using the 62-158, 3/4 H.P. motor, insert switch cord and power cord through hole as shown in Fig. 6.

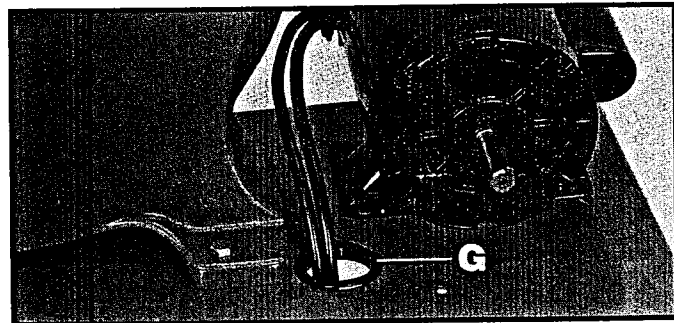

Fig. 6

ASSEMBLING SWITCH

If you purchased the 62-158, 3/4 H.P. motor, you received a switch and cord set connected to the motor. Assemble the switch to the stand as follows:

1. **IMPORTANT:** When assembling the switch to the stand, **MAKE SURE** the motor power cord is **NOT** connected to the power source.
2. Remove the outer hex nut (A) Fig. 7, from the switch stem. Leave external tooth lockwasher (B) and inside hex nut (C) on switch stem. **CAUTION:** The proper grounding of the switch to prevent shock hazard, depends on the use of the external tooth lockwasher in the manner shown.

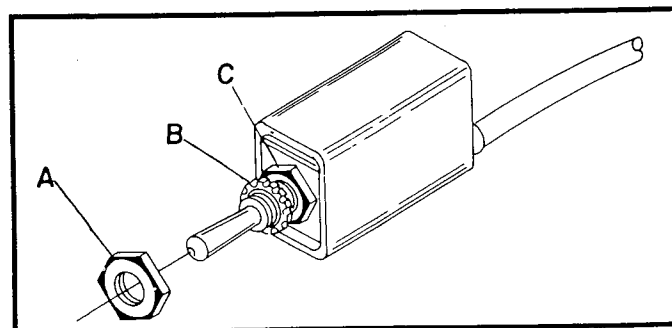

Fig. 7

in the down position.

4. Place the switch bracket (D) Fig. 8, on switch stem with key of switch bracket engaged with keyway in switch stem. Fasten switch in place with hex nut (A) that was removed in STEP 2. **NOTE:** The excess wire from the motor to the switch should be wrapped and tied and then positioned out of the way.

5. **IMPORTANT:** It is recommended that when the band saw is not in use, the switch be locked in the "OFF" position using a padlock. Catalog No. 49-031 Padlock is available as an accessory.

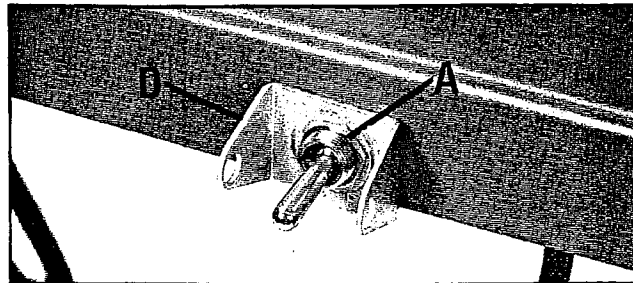

Fig. 8

ASSEMBLING BELT GUARD, MOTOR AND ARBOR PULLEYS, AND DRIVE BELT

1. Thread the six self-tapping screws (A) Fig. 9, about halfway into the six holes provided in the ledge of the inside belt and pulley guard (B) as shown.

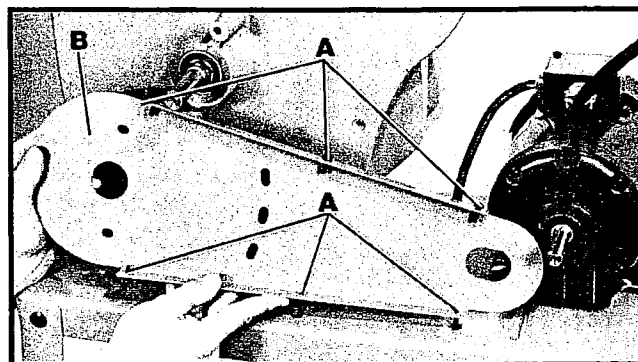

Fig. 9

2. Assemble the inside belt and pulley guard (B) Fig. 10, over the arbor and motor shafts as shown and fasten the guard to the machine using the two 1/2 inch-long hex head cap screws and flat washers (C). **NOTE:** Do not completely tighten the screws at this time.

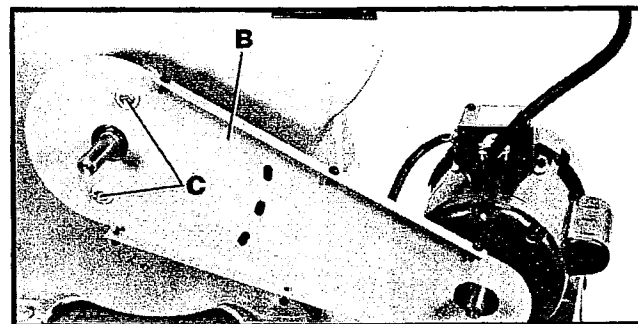

Fig. 10

3. Place the spacer (D) Fig. 11, into the countersunk hole (E) located behind the belt and pulley guard (B). Then insert the 2-3/4 inch hex head cap screw with flat washer (F) into the center hole (G), through the spacer (D) and thread it into the tapped hole (E).

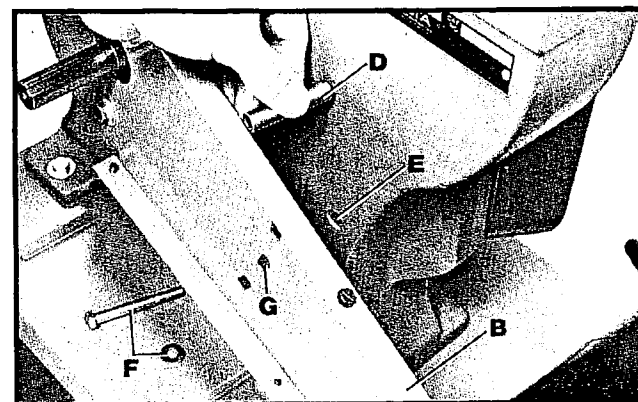

Fig. 11

4. **NOTE:** Make certain the arbor shaft (H) Fig. 12, and motor shaft (J) are centered in the holes of the belt and pulley guard (B) as shown, then tighten screws (C) and (F).

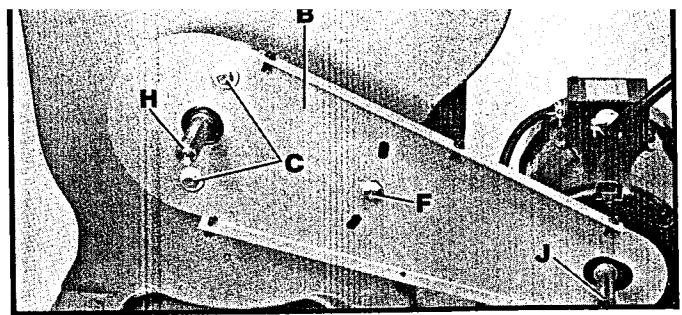

Fig.12

5. Assemble the arbor pulley (K) Fig. 13, to arbor shaft with hub of pulley in the "out" position. Insert key (L) in keyway of arbor shaft and tighten set screw (M).

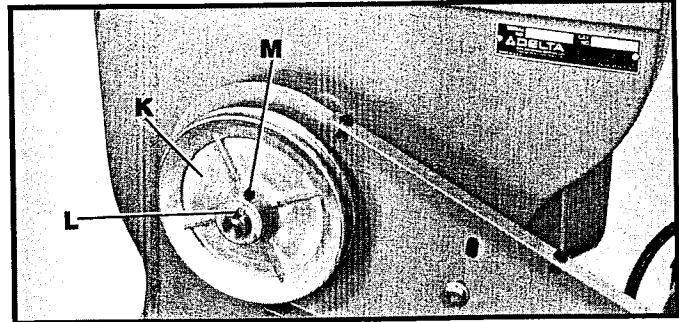

Fig.13

6. Assemble motor pulley (N) Fig. 14, to motor shaft with hub of pulley in the "in" position. Insert key (P) in keyway of motor shaft and tighten set screw (R) in motor pulley

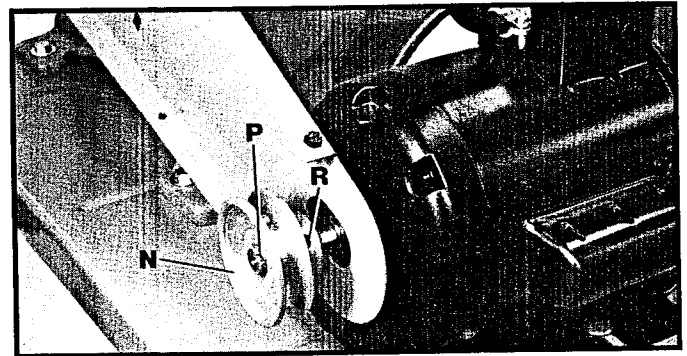

Fig.14

7. Assemble drive belt (S) Fig. 15, to the arbor pulley and motor pulley as shown. Using a straight edge, check to see if the arbor pulley (K) and the motor pulley (N) are aligned. If an adjustment is necessary, both pulleys can be moved in or out to obtain proper alignment. Adjust for proper belt tension by moving the motor in or out by loosening four mounting bolts, two of which are shown at (T). Correct belt tension is obtained when there is approximately 1/2 inch deflection at the center span of the belt (S) Fig. 15, using light finger pressure. **NOTE:** When proper belt tension is obtained and both pulleys are aligned, make certain to tighten all mounting hardware.

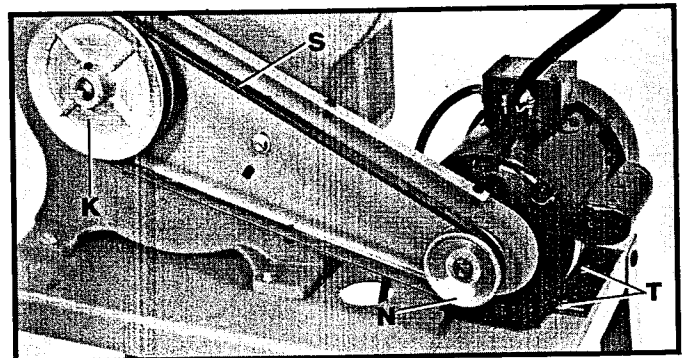

Fig.15

8. Assemble outer belt and pulley guard (V) to the inside belt and pulley guard and tighten the six screws, three of which are shown at (A) Fig. 16.

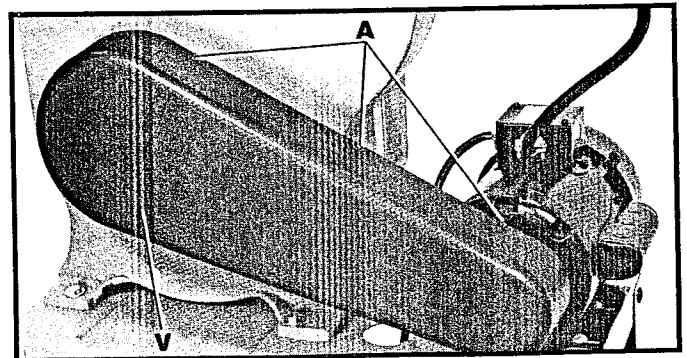

Fig.16

POWER CONNECTIONS

A separate electrical circuit should be used for your power tools. This circuit should not be less than #12 wire and should be protected with a 15 Amp time lag fuse. If an extension cord is used, use only 3-wire extension cords which have 3-prong grounding type plugs and 3-pole receptacles which accept the tools plug. For distances up to 100 feet use #12 wire. For distances up to 150 feet use #10 wire. Before connecting the motor to the power line, make sure the switch is in the "OFF" position and be sure that the electric current is of the same characteristics as stamped on motor nameplate. All line connections should make good contact. Running on low voltage will injure the motor. Have a registered electrician replace or repair damaged or worn cords immediately.

GROUNDING INSTRUCTIONS

CAUTION: This tool must be grounded while in use, to protect the operator from electric shock. The motor is shipped wired for 115 Volt, Single Phase and is equipped with an approved 3-conductor cord and 3-prong grounding type plug to fit the proper grounding type receptacle, as shown in Fig. 17. The green conductor in the cord is the grounding wire.
CAUTION: Never connect the green wire to a live terminal.

An adapter, shown in Fig. 18, is available for connecting 3-prong grounding type plugs to 2-prong receptacles. **THIS ADAPTER IS NOT APPLICABLE IN CANADA.** The green-colored rigid ear, lug, etc., extending from the adapter is the grounding means and must be connected to a permanent ground such as to a properly grounded outlet box, as shown in Fig. 18.

CAUTION: IN ALL CASES, MAKE SURE THE RECEPTACLE IN QUESTION IS PROPERLY GROUNDED. IF YOU ARE NOT SURE, HAVE A CERTIFIED ELECTRICIAN CHECK THE RECEPTACLE.

DO NOT EXPOSE TO RAIN OR USE IN DAMP LOCATIONS.

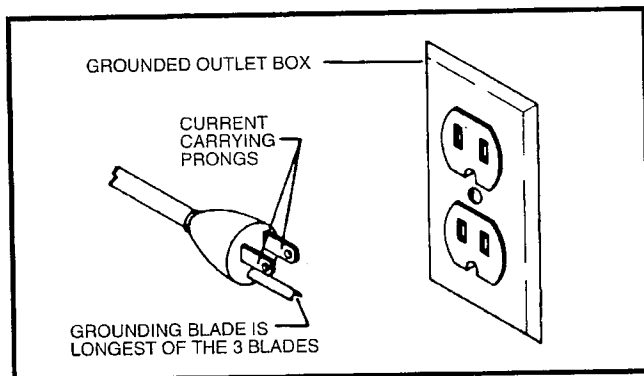

Fig. 17

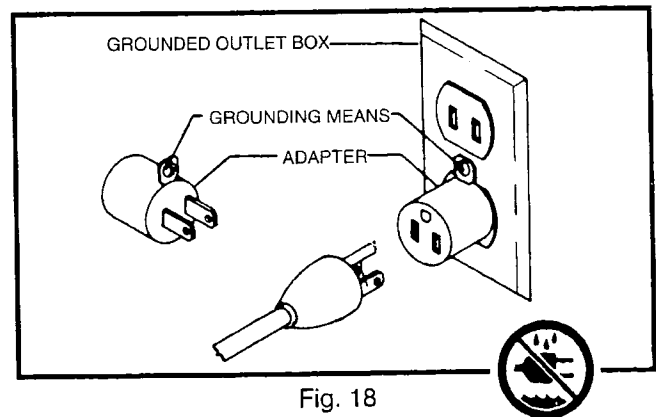

Fig. 18

TABLE INSERT

Place table insert (A) Fig. 19, in the hole provided in the table, making sure the pin (B) in the table engages one of the indents in the table insert.

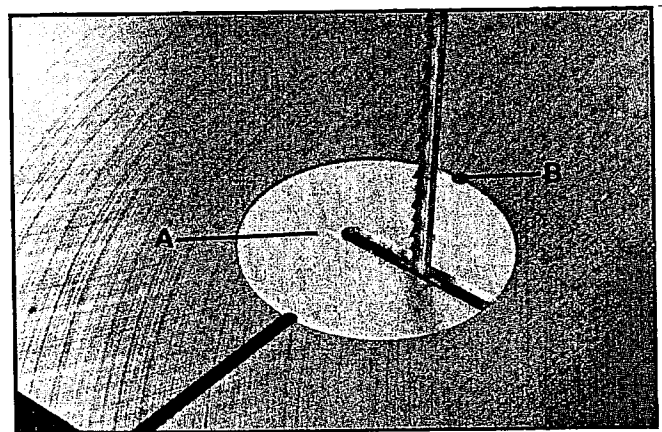

Fig. 19

TILTING THE TABLE

The table on your band saw can be tilted 45 degrees to the right and 10 degrees to the left. To tilt the table, loosen the two knobs (A) Fig. 20; tilt the table to the desired angle and tighten the two knobs (A).

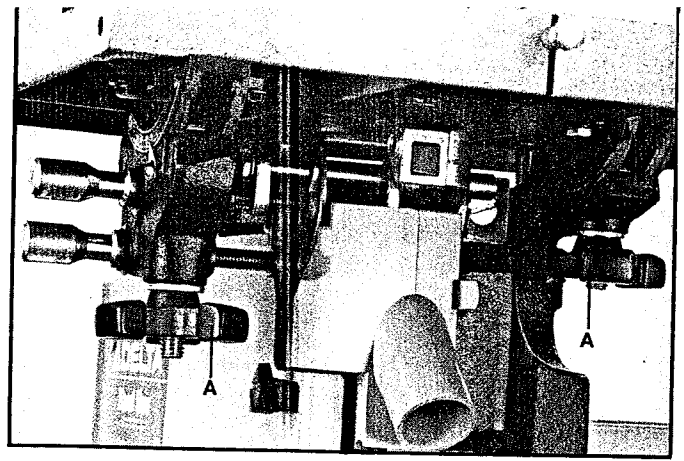

Fig. 20

ADJUSTING TABLE STOP

The band saw is equipped with an adjustable table stop (A) Fig. 21, that allows the table to be set perfectly at 90 degrees with the blade.

Tilt the table to the left until the table stop (A) Fig. 21, contacts the bottom of the table. Place a square on the table and against the blade as shown in Fig. 22, and check to see if the blade is 90 degrees to the table surface. If an adjustment is necessary, proceed as follows:

1. Tilt the table slightly to the right and tighten table lock knobs.
2. Turn adjustment nut (B) Fig. 21, right or left as necessary to raise or lower table stop (A). **IMPORTANT:** Certain models of band saws will have an additional locknut assembled to the end of the table stop (A) Fig. 21, directly under casting (C). Loosen locknut and turn adjustment nut (B) right or left as needed to raise or lower the table stop (A). Tighten locknut after adjustment is made.
3. Lower the table and make certain the table is 90 degrees to the blade as shown in Fig. 22.
4. It is necessary to remove the adjustable table stop (A) Fig. 21, when tilting the table to the left.

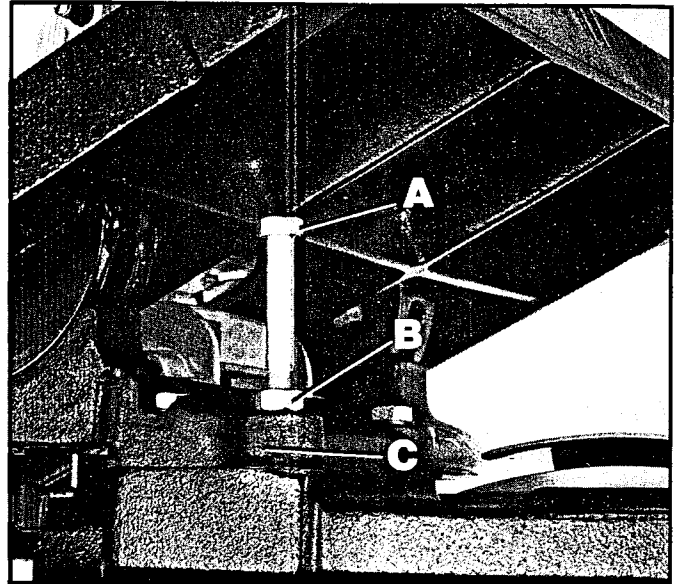

Fig. 21

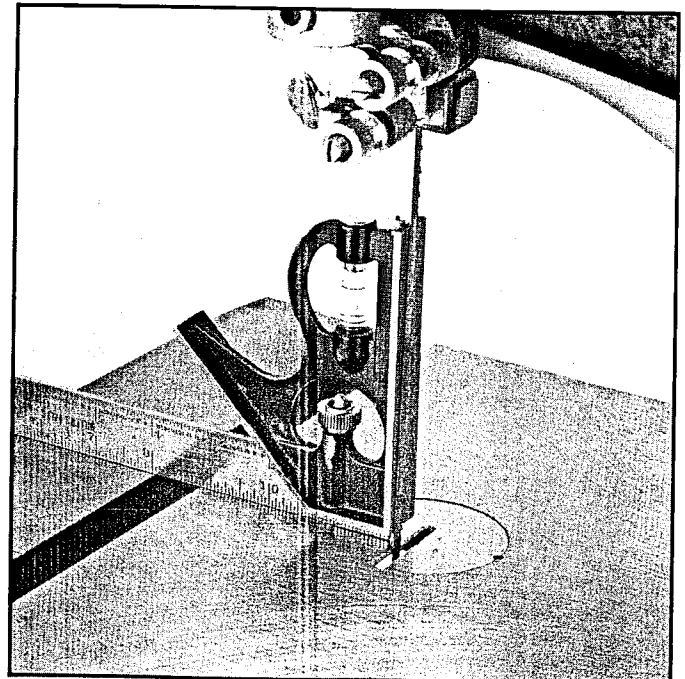

Fig. 22

BLADE TENSION

On the back of the upper wheel slide bracket there is a series of graduations. These indicate the proper tension for various widths of blades. With the blade on the wheels, turn the knob (A) Fig. 23, to raise or lower the wheel, until the red fiber washer (B) is in line with the proper graduation for the size of blade being used.

The graduations will be found correct for average work, and are not affected by rebrazing of the saw blade. We urge you to use these graduations until you have become familiar enough with the operation of the Band Saw to vary the tension for different kinds of blades or work. Over-straining is a common cause of blade breakage and other unsatisfactory blade performance. Release the tension when the machine is not in use.

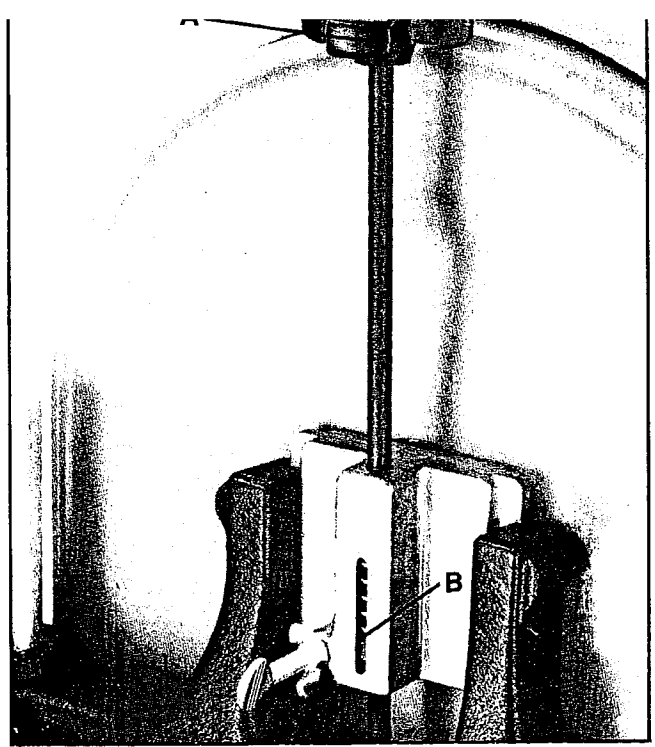

Fig. 23

TRACKING THE BLADE

IMPORTANT: Before tracking the blade, make sure the blade guides and blade support bearings are clear of the blade so as not to interfere with the tracking adjustment.

After tension has been applied to the blade, turn the wheels slowly forward by hand and watch the blade (A) Fig. 24, to see that it travels in the center of the upper tire. If the blade begins to creep toward the front edge, loosen the wing nut (B) Fig. 25, and tighten the thumb screw (C). This will tilt the top of the wheel toward the back of the machine and will draw the blade toward the center of the tire. If the blade creeps toward the back edge, turn the thumb screw in the opposite direction.

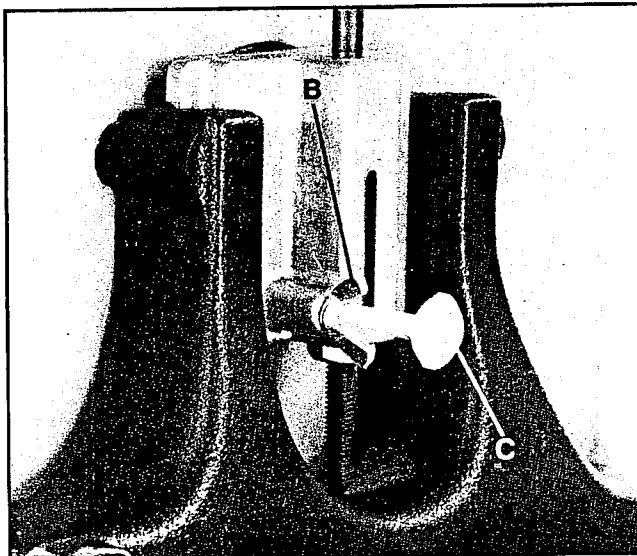

Fig. 25

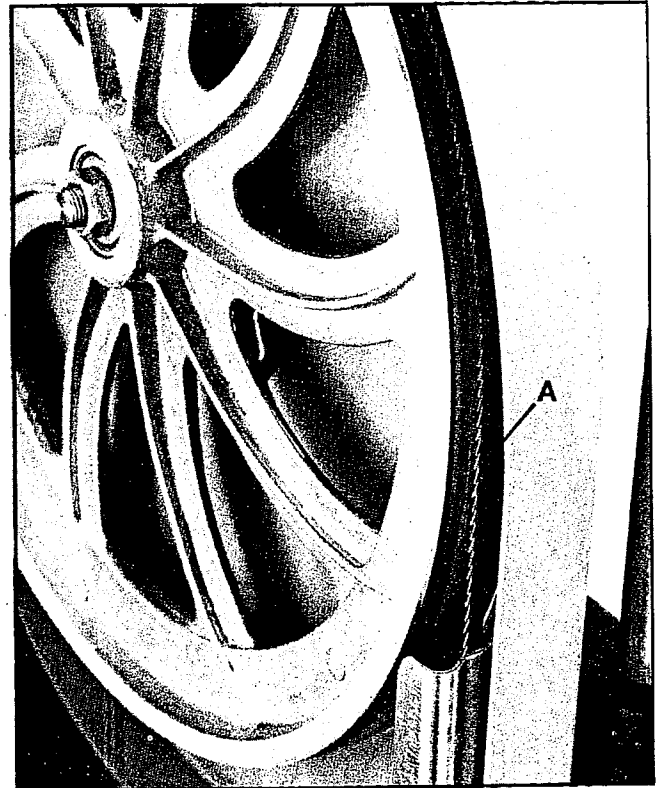

Fig. 24

Adjust the thumb screw (C) Fig. 25, only a fraction of a turn at a time. **NEVER TRACK THE BLADE WHILE THE MACHINE IS RUNNING.** After the blade is tracking in the center of the tires, tighten the wing nut (B) Fig. 25.

ADJUSTING UPPER BLADE GUIDE ASSEMBLY

The upper blade guide assembly (A) Fig. 26, should always be set as close as possible to the top surface of the material being cut by loosening lock knob (B) and moving the guide assembly (A) to the desired position.

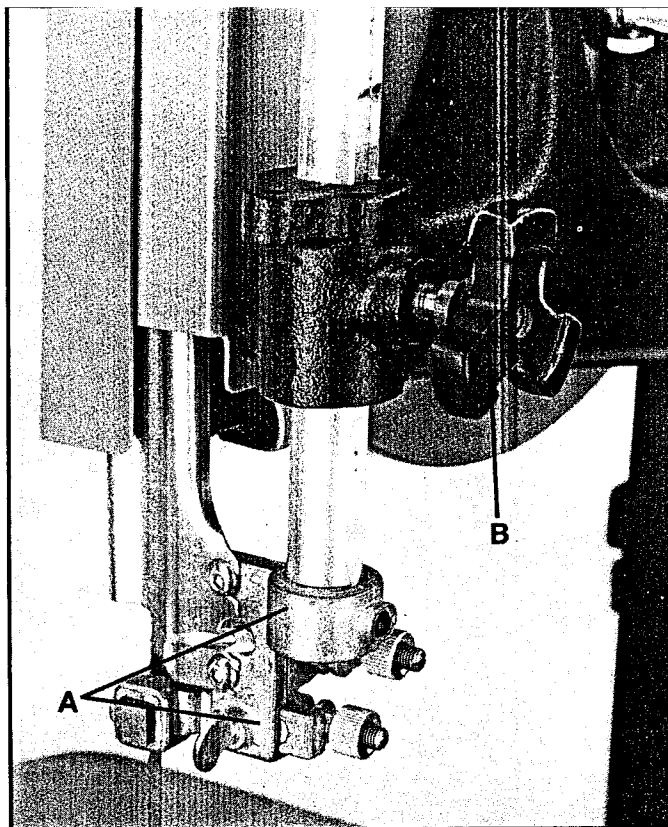

Fig. 26

The upper blade guide assembly should also be adjusted so that the blade guides (A) Fig. 27, are flat with the blade. If an adjustment is necessary, loosen screw (B) and rotate the complete guide assembly (C) until the blade guides are flat with the blade.

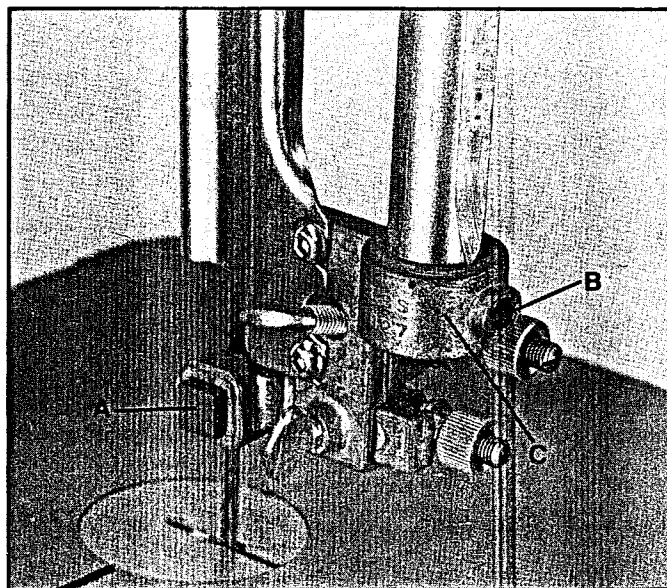

Fig. 27

UPPER BLADE GUIDES AND BLADE SUPPORT BEARING

The upper blade guides and blade support bearings are adjusted only after the blade is tensioned and tracking properly. To adjust proceed as follows:

1. The upper blade guides (A) Fig. 28, are held in place by means of the set screws (B). Loosen the set screws (B) to move the guides (A) as close as possible to the side of the blade, being careful not to pinch the blade. Then tighten the screws (B).
2. The guides (A) Fig. 28, should then be adjusted so that the front edge of the guides is just behind the "gullets" of the saw teeth. The complete guide block bracket can be moved in or out by loosening thumb screw (C) and turning knurled knob (D) Fig. 28. When guides (A) are set properly, tighten thumb screw (C).
3. The upper blade support bearing (E) Fig. 28, prevents the blade from being pushed too far to the back which could damage the set in the saw teeth. The support bearing (E) should be set 1/64" behind the blade by loosening thumb screw (F) and turning knurled knob (G) to move the support bearing (E) in or out.
4. The blade support bearing (E) should also be adjusted so the back edge of the blade overlaps the outside diameter of the ball bearing by about 1/16". The bearing (E) is set on an eccentric and to change position remove screw (H) and bearing (E) Fig. 28. Loosen thumb screw (F), back out screw (G) and reposition shaft that bearing (E) is attached to.

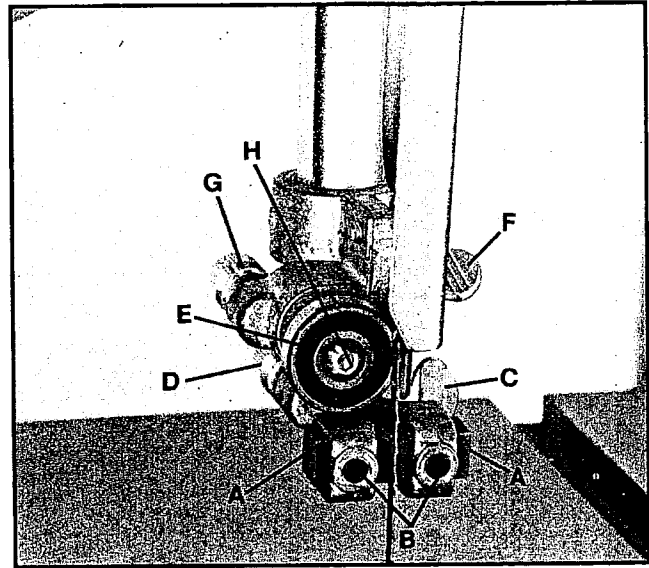

Fig. 28

ADJUSTING LOWER BLADE GUIDES AND BLADE SUPPORT BEARING

The lower blade guides and blade support bearing should be adjusted at the same time as the upper guides and bearing as follows:

1. Loosen the two screws (A) Fig. 29, and move the guides (B) as close as possible to the side of the blade, being careful not to pinch the blade. Then tighten screws (A).
2. The front edge of the guide blocks (B) should be adjusted so they are just behind the "gullets" of the saw teeth by turning the knurled knob (C) Fig. 29.
3. The lower blade support bearing (D) Fig. 29, should be adjusted so it is about 1/64" behind the back of the blade by turning the knurled knob (E).

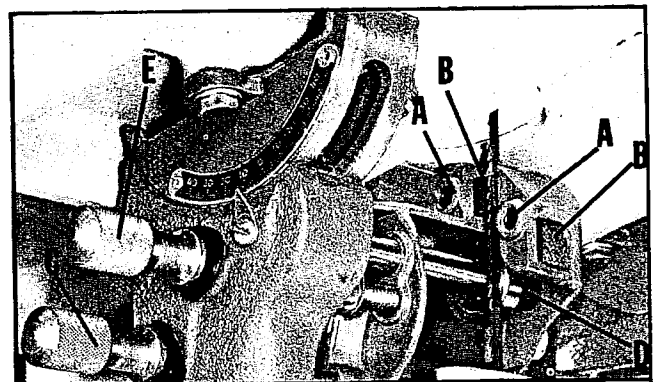

Fig. 29

CHANGING BLADES

To change blades, proceed as follows:

1. Open the upper and lower wheel guards.
2. Release tension on the band saw blade.
3. Remove the table adjustment pin and table insert.
4. Slip the blade off the wheel and guide it out through the slot in the table.
5. To install a new blade, reverse the above procedure.

BAND SAW BLADES

A band saw blade is a delicate piece of steel that is subjected to tremendous strain. You can obtain long use from a band saw blade if you give it fair treatment. Be sure you use blades of the proper thickness, width and temper for the various types of material to be cut.

Always use the widest blade possible. Use the narrow blades only for sawing small, abrupt curves and for fine delicate work. This will save blades and will produce better work. Band saw blades may be purchased, welded, set and sharpened ready for use. For cutting wood and similar materials Delta can supply blades in widths of 1/8, 3/16, 1/4, 3/8, 1/2 and 3/4 inches.

File and set the wood cutting blades whenever you find it requires pressure to make them cut. If a blade is broken it can be brazed or welded; however, if it has become badly work-hardened it will soon break in another place. If you are not equipped to file, set and braze or weld blades, take them to a saw filer for reconditioning.

Any one of a number of conditions may cause a band saw blade to break. Blade breakage is, in some cases, unavoidable, being the natural result of the peculiar stresses to which such blades are subjected. It is, however, often due to avoidable causes, most often to lack of care or judgment on the part of the operator in mounting or adjusting the blade or guides. The most common causes of blade breakage are: (1) faulty alignments and adjustments of the guides, (2) forcing or twisting a wide blade around a curve of short radius, (3) feeding too fast, (4) dullness of the teeth or absence of sufficient set, (5) excessive tightening of the blade, (6) top guide set too high above the work being cut, (7) using a blade with a lumpy or improperly finished braze or weld and, (8) continuous running of the saw blade when not in use for cutting.

New blades for the standard 14 inch Band Saw are 93-1/2 inches long. The adjustment will accommodate blades up to a maximum length of 94 inches and to a minimum length of 91-1/2 inches. When equipped with the No. 28-984 Height Attachment, new blades should be 105 inches long; maximum and minimum lengths are 106 and 103-1/2 inches.

OPERATING THE BAND SAW

Before starting the machine, see that all adjustments are properly made and the guards are in place. Turn the pulley by hand to make sure that everything is correct **BEFORE** turning on the power.

Keep the top guide down close to the work at all times. Do not force the material against the blade too hard. Light contact with the blade will permit easier following of the line and prevent undue friction, heating and work-hardening of the blade at its back edge.

KEEP THE SAW BLADE SHARP and you will find that very little forward pressure is required for average cutting. Move the stock against the blade steadily and no faster than will give an easy cutting movement.

Avoid twisting the blade by trying to turn sharp corners. Remember, you must saw around corners.

CUTTING CURVES

When cutting curves, turn the stock carefully so that the blade may follow without being twisted. If a curve is so abrupt that it is necessary to repeatedly back up and cut a new kerf, either a narrow blade is needed or a blade with more set is required. The more set a blade has, the easier it will allow the stock to be turned, but the cut is usually rougher than where a medium amount of set is used.

In withdrawing the piece being cut, in order to change the cut, or for any other reason, the operator must be careful that he does not accidentally draw the blade off the wheels. In most cases it is easier and safer to turn the stock and saw out through the waste material, rather than try to withdraw the stock from the blade.

Centres de service après-vente agréés Delta (Porter-Cable) du Canada

DELTA SERVICE CENTRES

CENTRES DE SERVICE APRÈS-VENTE DE L'USINE DELTA

ALBERTA

Bay #6, 2520-23 St. N.E.
Calgary, Alberta
 T2E 8L2
 TEL: (403) 735-6166
 FAX: (403) 735-6144

BRITISH COLUMBIA

8520 Baxter Place
Burnaby, B.C.
 V5A 4T8
 TEL: (604) 420-0102
 FAX: (604) 420-3522

MANITOBA

1699 Dublin Avenue
Winnipeg, Manitoba
 R3H 0H2
 TEL: (204) 633-9259
 FAX: (204) 632-1976

ONTARIO

644 Imperial Road
Guelph, Ontario
 N1H 6M7
 TEL: (519) 836-2840
 FAX: (519) 836-9352
Mobile Service

QUÉBEC

1447, Bégin
St-Laurent, (Mtl), P.Q.
 H4R 1V8
 TEL: (514) 336-8772
 FAX: (514) 336-3505

Suite 202
 2022, rue Lavoisier
Ste-Foy, P.Q.
 G1N 4L5
 TEL: (418) 681-7305
 FAX: (418) 681-1695

HEAD OFFICE SIÈGE SOCIAL

Delta International Machinery
 P.O. Box 848
 644 Imperial Road
Guelph, Ontario
 N1H 6M7
 TEL: (519) 836-2840
 FAX: (519) 836-9352

ALBERTA

Edmonton, Alberta
 Can-Tech Tool Service
 9252-34A Avenue
 T6E 5P4
 (403) 450-6389

Edmonton, Alberta
 O.K. Power Tool Repair Ltd.
 14740-115 Avenue
 T5M 3B9
 (403) 455-0373

Grand Prairie, Alberta
 Ber-Mar Rewind
 9609-109th Street
 T8V 4E3
 (403) 532-0818

Lethbridge, Alberta
 Central Electric Ltd.
 124 N Mayor Magrath Drive
 T1H 3P4
 (403) 327-5995

Medicine Hat, Alberta
 Randy's Refrigeration Ltd.
 694 South Railway St., S.E.
 T1A 2W1
 (403) 526-0463

Red Deer, Alberta
 McAuley Electric Motor Ltd.
 5301-50th Avenue
 T4N 4B6
 (403) 346-3361

BRITISH COLUMBIA

Abbotsford, B.C.
 Abbotsford Tool Centre
 33723 A. King Road
 V2S 4N2
 (604) 859-9023

Campbell River, B.C.
 Andrews Lawnmower Service Ltd.
 80 Westgate Road
 V9W 1R2
 (604) 923-7122

Castlegar, B.C.
 Martech Electrical Systems Ltd.
 1700 Woodland Drive
 P.O. Box 3403
 V1N 3N8
 (604) 365-2115

Courtenay, B.C.
 Andrews Lawnmower Service Ltd.
 883 McPhee Avenue
 V9N 3A1
 (604) 334-4439

Cranbrook, B.C.
 Sarc Repair Ltd.
 16 13th Avenue S.
 V1C 2R7
 (604) 426-6333

Kamloops, B.C.
 Thompson Valley Rewind
 1647 Valleyview Dr.
 V2C 4B6
 (604) 374-1633

Kelowna, B.C.
 Central Electric Motor Rewind Ltd.
 #1-1960 Windsor Road
 V1Y 4R5
 (604) 860-4415

Langley, B.C.
 A.C. Power Tool Clinic Ltd.
 #105 19835 56th Ave.
 V3A 3X8
 (604) 530-3550

Nanaimo, B.C.
 Solar Electric Repairs Ltd.
 20 A Cliff Street
 V9R 5E5
 (604) 753-1731

Penticton, B.C.
 A.C. Motor Electric Ltd.
 259 East Okanagan Avenue
 V2A 3J8
 (604) 493-1440

Prince George, B.C.
 Accurate Tool & Repair
 3660-18th Avenue
 V2N 1A9
 (604) 562-8833

Surrey, B.C.
 Delta Tool Repair Ltd.
 #2 7533-135th Street
 V3W 0N6
 (604) 591-3230

Vernon, B.C.
 E.E. Electrical Enterprises Ltd.
 4600 31st Street
 V1T 5J9
 (604) 542-1166

Victoria, B.C.
 A.B.C. Electric Limited
 831 Yates Street
 V8W 1M1
 (604) 382-7221

Victoria, B.C.
 Troy Electrical Repairs
 Unit #1, 3131 Delta St.
 V8Z 1A6
 (604) 382-7442

MANITOBA

Brandon, Manitoba
 Harold's Electric Service
 362 Pacific Avenue
 R7A 0H5
 (204) 727-7292

Steinbach, Manitoba
 Palmite Electric Motors
 Box 3308
 R0A 2A0
 (204) 326-9271

Thompson, Manitoba
 KNC Electric Ltd.
 P.O. Box 428
 R8N 1N2
 (204) 778-7333

N.W.T.

Yellowknife, NWT
 Polar Tech
 12 Balsillie Crt.
 X1A 3H8
 (403) 873-8324

NEW BRUNSWICK

Bathurst, N.B.
 Roger's Electric Motor Service
 1561 Miramichi Avenue
 E2A 3Y4
 (506) 548-8711

Edmundston, N.B.
 Edmundston Electric Motor Service Ltd.
 6 Lacombe Street
 E3V 3K3
 (506) 735-4485

Fredericton, N.B.
 Electric Motor Service
 129 Westmorland St.
 E3B 3L4
 (506) 458-8770

Riverview, N.B.
 Doug's Tool Repair
 43 Allan Street
 E1B 4B3
 (506) 386-3366

Saint John, N.B.
 A.B. McLean & Company Ltd.
 116 Victoria Street
 E2K 1L6
 (506) 634-8184

Saint John, N.B.
 Eastern Distributors Limited
 38 Bayside Drive
 E2J 1A2
 (506) 634-8314

NEWFOUNDLAND

Cornerbrook, NFLD
 Rideout Tool & Supply
 115 Humber Road
 A2H 1G1
 (709) 634-3294

Gander, NFLD
 Domestic Service Centre
 Box 83
 43 McCurdy Dr.
 A1V 1W5
 (709) 256-7738

St. John's NFLD
 Rideout Tool & Supply Ltd.
 222 Kenmount Road
 A1B 3R2
 (709) 754-2240

Shouf Harbour, NFLD
 Greening's Electrical Maintenance Limited
 P.O. Box 174
 A0C 2L0
 (709) 466-6606

NOVA SCOTIA

Dartmouth, N.S.
 Electric Motor Shop Ltd.
 673 Main Street
 B2W 3T6
 (902) 463-8165

Dartmouth, N.S.
 Fader Industries
 83 Shore Road
 B3A 1A5
 (902) 466-2333

Halifax, N.S.
 Village Power Shop Ltd.
 2756 Gladstone St.
 B3K 4W5
 (902) 455-0208

Sydney, N.S.
 Dale Burke Auto Electric
 1081 Upper Prince St.
 B1P 5P5
 (902) 564-4337

Truro, N.S.
 Smith Motor & Pump
 333 Industrial Avenue
 B2N 4A7
 (902) 893-7291

ONTARIO

Ajax, Ontario
 J.D. Air & Electric
 U3-676 Monarch Ave.
 L1S 4S2
 (905) 427-2595

Bancroft, Ontario
 Bancroft Electric Motors
 Box 1763
 K0L 1C0
 (613) 332-4705

Barrie, Ontario
 Master Sales & Service
 16 Mulcaster Street
 L4M 3M1
 (705) 726-7102

Belleville, Ontario
 EmSCO Ltd.
 57 Cannifton Road
 K8N 4V1
 (613) 966-3234

Brantford, Ontario
 Gilbert-McEachern Electric Ltd.
 225 Drummond St.
 N3S 6B3
 (519) 753-0465

Burlington, Ontario
 Bayshore Tool & Equipment
 2312 Industrial Street
 L7P 1A1
 (905) 332-0554

Cambridge, Ontario
 Speedy Tool Repair
 Box 21102, Holiday
 Postal Outlet N3C 4B1
 (519) 624-0122

Chatham, Ontario
 Ron's Sales & Service
 208 Queen Street
 N7M 2H1
 (519) 351-8331

Cornwall, Ontario
 Power Tool Service
 423 Fourth Street, W.
 K6J 2S7
 (613) 938-1292

Downsview, Ontario
 After Sales Repair Service
 167 Limestone Cresc.
 M3J 2R1
 (416) 663-8858

Englehard, Ontario
 Spruce Grove Pumps
 R.R. #2
 P0J 1H0
 (705) 544-8254

Etobicoke, Ontario
 Karl's Power Tools Sales and Service
 25-22 Goodmark Place
 M9W 6R2
 (416) 675-1310

Hamilton, Ontario
 Active Tool Repair
 800 Barton St. E. #2
 L8L 3B3
 (905) 545-7646

Hamilton, Ontario
 Apollo Tool Repair & Sales Ltd.
 180 Parkdale Ave. N.
 L8H 5X2
 (905) 544-5202

Hanover, Ontario
 Wayne's Electric Ltd.
 626-12th Avenue
 N4N 2V5
 (519) 364-4020

Huntsville, Ontario
 Huntsville Armature
 51 Ferguson Road
 RR 1
 P0A 1K0
 (705) 789-9301

Kingston, Ontario
 Boyd Electric Co. Ltd.
 833 Portsmouth Ave.
 K7M 1W6
 (613) 548-4888

Kitchener, Ontario
 RMW Electric
 969 Guelph Street
 N2H 5Z2
 (519) 744-1821

London, Ontario
 Moore Tool & Motor Service
 960 Elias St., Unit 2
 N5W 3P4
 (519) 679-6326

Milton, Ontario
 Sure-Cut Industries Ltd.
 925 Main St., E.
 Units 2 & 3
 L9T 4H8
 (905) 878-8790

Mississauga, Ontario
 Bertsch Power Tool Service Ltd.
 1320 Midway Blvd.
 Unit 18
 L5T 2K4
 (905) 670-7716

(continued)
 (suite à la page suivante)

Centres de service après-vente agréés Delta (Porter-Cable) du Canada - Suite ...

Niagara Falls, Ontario
Power Tool Repair Centre
4661 Queen Street
L2E 2L9
(905) 357-4333

North Bay, Ontario
Gateway Electric
1570 Main Street West
P1B 2X3
(705) 476-5814

Oakville, Ontario
Industrial Tool Repair
Centre
2140 Speers Road
L6L 2X8
(905) 827-5444

Orillia, Ontario
Orser Electric 1995 Ltd.
301 Forest Avenue
L3V 6K7
(705) 326-6427

Ottawa, Ontario
Ernie's Electric Ltd.
1732 Woodward Dr.
K2C 0P8
(613) 228-9480

Owen Sound, Ontario
Murray's Saw & Knife
Service
1351 2nd Avenue East
N4K 2J5
(519) 376-2495

Peterborough, Ontario
Dependable Electric
Motor Service
861 Webber Avenue
K9J 5X9
(705) 742-0732

Richmond Hill, Ontario
Dubiner Industries Limited
40 West Pearce St. #2
L4B 1C5
(905) 771-6111

St. Catharines, Ontario
Kaupp Electric
225 Merritt Street
L2T 1J7
(905) 227-1661

Sarnia, Ontario
Serv-a-Tool and Repairs
Ltd.
866 Philip Street
N7T 1Z6
(519) 344-8837

Sault Ste. Marie, Ontario
Sabre Sharpening Centre
677 MacDonald Ave.
Unit 11
P6B 1J4
(705) 254-3711

Scarborough, Ontario
George Power Tools
Service
1365 Morningside Ave.
Unit 11
M1B 3C5
(416) 286-3933
(416) 286-3934

South Porcupine, Ontario
Porcupine Air & Electric
Tool Repairs
51 Smith Street
P0N 1H0
(705) 235-8950

Stratford, Ontario
Culliton Brothers Ltd.
473 Douro Street
N5A 6W3
(519) 271-1981

Sudbury, Ontario
Northern Auto Scope
U2-122 Douglas St. West,
Bag 5010
P3A 4S2
(705) 673-8148

Sudbury, Ontario
Sudbury Service Ctr.
83 Lome St., S.
P3C 4P2
(705) 673-5085

Thunder Bay, Ontario
Mahon Electric Co. Ltd.
340 Waterloo Street
P.O. Box 307, Str. "F"
P7C 4V9
(807) 623-8471

Tilsonburg, Ontario
Merv Davis Electric
346 Simcoe Street
N4G 2J8
(519) 842-7194

Toronto, Ontario
AMT Power Tool & Saw Ltd.
1182 Castlefield Ave.
M6B 1G1
(416) 783-6095

Toronto, Ontario
Miller Air & Electric Tool Co.
7 Gilead Place
M5A 3C8
(416) 368-5646

Windsor, Ontario
Monelco Motors Ltd.
333 Eugénie St., E.
N8X 2Y2
(519) 969-9660

PRINCE EDWARD ISLAND

Charlottetown, P.E.I.
Chandler Motor Repair
70 Kensington Road
C1A 5J2
(902) 892-6345

QUÉBEC

Alma, Lac Ste. Jean, P.Q.
Outillage Moteur
Électrique Alma
228 Boul. Dequen Nord
G8B 5N5
(418) 668-2022

Aylmer, P.Q.
Jacques Leblanc
Mobile Service
50 Terrace Crescent
J9H 2N3
(613) 720-6040

Beloeil, P.Q.
Placide Mathieu & Fils Inc.
670 rue Picard
J3G 5X9
(514) 467-3565

Chicoutimi (Nord), P.Q.
J. Siros Électrique Inc.
2203 rue Roussel
G7G 1W4
(418) 543-3308

Crabtree, Quebec
Les Services D.E.R. Enr.
335 Ch. Ste. Marie
J0K 1B0
(514) 754-2895

Dolbeau, P.Q.
Moteur Électrique Conroy
Ltée
1849 boul. Wallberg
G8T 1J1
(418) 276-6596

Dollard Des Ormeaux, P.Q.
Entreprise Clem
Herscheid Inc.
4307 St. John Blvd.
H9H 2A4
(514) 626-1683

Drummondville, P.Q.
Docteur de l'Outil
Melam Enr
200A Rue Dorion
J2C 1T9
(819) 478-1109

Gaspé, P.Q.
SOS Electric Ménager Enr.
23 Adams
G0C 1R0
(418) 368-1779

Gatineau, P.Q.
Équip. Brabant & Fils.
776 Boul. Maloney Est.
J8P 1G6
(819) 663-2463

Granby, P.Q.
Armature Shefford Inc.
200 rue Cartier
J2G 5A6
(514) 375-1414

Grand Mère, P.Q.
Général Surplus
320 - 12 rue
G9T 4A5
(819) 538-6383

Greenfield Park, P.Q.
Service D'Outils ACM
5 Morley
Suite 114A
J4V 2Y8
(514) 466-1173

Jonquière, P.Q.
Moteur Saguenay Enr.
2885 boul. du Royaume
G7S 4K6
(418) 548-7161

Laval, P.Q.
S. Brodaric
4103 MacKenzie Court
H7W 3C9
(514) 688-9399

Laval, P.Q.
Service D'Outils F.G.L. Inc.
1617 Autoroute 440 O.
H7L 3W3
(514) 682-7979

Louiseville, P.Q.
Outillage Lam-Ré Inc.
61 rue St-Aimé
J5V 2A9
(819) 228-8444

Mont-Laurier, P.Q.
Atelier Ge-Ma Enr.
395 rue Dupont
J9L 2R6
(819) 623-6622

Montmagny, P.Q.
Réparation Électrique
170 4e Rue
G5V 3L5
(418) 248-2072

Montréal, P.Q.
Lafamme Électrique
1569 rue Amherst
H2L 3L5
(514) 527-9151

Rimouski, P.Q.
Dickner Inc.
559 rue Lausanne
G5L 7C9
(418) 723-7936

Rivière Du-Loup, P.Q.
Dickner Inc.
370 Le Miscouala
G5R 2Z2
(418) 867-1824

Rouyn-Noranda, P.Q.
Équipement TNO Inc.
1250 Boul Saguenay
PO 2157
J9X 5A6
(819) 764-3221

St. David-Ste-Lévis, P.Q.
Larivière Moteur Électrique
4895 Boul. de la rive sud
G6W 1H3
(418) 837-7982

St-Hyacinthe, P.Q.
Centre De Service St.
Hyacinthe Enr.
3400 Laframboise
J2S 4Z4
(514) 774-7728

St. Jean, P.Q.
Landry Repare tout inc.
825 St. Jacques
J3B 2N2
(514) 346-2005

St. Jérôme, P.Q.
Centre d'électrique
Jérômien Inc.
712 St. Georges
J7Z 5C6
(514) 430-2676

St. Joseph De Sorel, P.Q.
Électro-Moteur Richelieu
602 St. Pierre Street
J3R 1A8
(514) 742-0203

Ste-Agathe, P.Q.
Electro G.C. Enr.
60 St-Vincent
J8C 2A6
(819) 326-4851

Sept-Iles, P.Q.
Centre de Location
Sept-Iles
1175 Boul. Laure
G4S 1S1
(418) 962-4230

Sherbrooke, P.Q.
Atelier d'Outils
Électriques Enr.
991 King Ouest
J1H 1S3
(819) 567-1775

Trois-Rivières, P.Q.
Outils Mauriciens Inc.
2444 bvd. Des Récollets
G8Z 3X7
(819) 373-1024

Val D'or, P.Q.
Hytex 85 Inc.
1710 3e Avenue
J9P 1W2
(819) 825-1475

Valleyfield, P.Q.
Centre de Réparation
Valleyfield Inc.
151 rue Maden
J6S 3V5
(514) 373-6055

Victoriaville, P.Q.
Baril Électrique Inc.
444 Cantin
G6R 7E6
(819) 752-4480

Ville St-Gabriel, P.Q.
Beaulieu Électrique Ltée
130 rue Dequoy
J0K 2N0
(514) 835-4781

SASKATCHEWAN

Lloydminster, Sask.
Dzus Motor Repair
4201 52nd Street
S9V 0Y9
(306) 825-7337

N. Battleford, Sask.
Ray's Electric Motor
Rebuilders
11152 8th Avenue
S9A 2N4
(306) 445-1611

Prince Albert, Sask.
P.A. Electric Service
129 16th Street W.
S6V 3V2
(306) 764-4236

Regina, Sask.
United Motor Electric
1234 Scarth Street
S4R 2E5
(306) 352-9744

Saskatoon, Sask.
K & J Repair
#3 1622 Ontario Ave.
S7K 1S8
(306) 244-1164

Swift Current, Sask.
United Motor Electric Ltd.
141 8th Avenue N.W.
S9H 0Z5
(306) 773-2058

Yorkton, Sask.
Bonsal's Appliance
Repair Ltd.
76-7th Avenue South
S3N 2V7
(306) 783-8991

YUKON

Whitehorse, Yukon
Oscar's Electric Co. Ltd.
310 Alexander Street
Y1A 2L6
(403) 667-2330



09/5/95



PORTER-CABLE

DELTA/PORTER-CABLE GUARANTEE

Delta is proud of the quality power tools it sells. The component parts of our tools are inspected at various stages of production and each finished tool is subjected to a final check before being packaged for shipment. Because of our confidence in our engineering quality, Delta agrees to repair or replace any part or parts of Delta/Porter-Cable Power Tools and accessories which examination proves to be defective in workmanship or material. The warranty period for Delta brand is two years, for Porter-Cable, one year. Any alleged defective part or parts must be returned prepaid to the Delta factory or one of the service centres. The guarantee does not include repair labour or parts replacement required because of misuse, abuse, or normal wear and tear. Repairs made by other than our factory, Delta service centre or authorized service station relieve Delta of further liability under this guarantee. **THIS GUARANTEE IS MADE EXPRESSLY IN PLACE OF ALL OTHER GUARANTEES OR WARRANTIES, EXPRESSED OR IMPLIED, WITH RESPECT TO QUALITY, MERCHANTABILITY, OR FITNESS FOR A PARTICULAR PURPOSE.**

GARANTIE DELTA/PORTER-CABLE

Delta est fière de la qualité des outils électriques qu'elle met sur le marché. Leurs composants sont inspectés à chaque étape de la fabrication, et chaque outil subit une dernière vérification avant d'être emballé pour l'envoi. Pour confirmer l'entière confiance de Delta dans la qualité technique de ses produits, la compagnie s'engage à réparer ou à remplacer tout élément ou accessoire d'un outil électrique Delta/Porter-Cable présentant un défaut dûment reconnu de matière ou de fabrication. La garantie est d'une durée de deux (2) ans pour les articles de la marque Delta et d'un an pour les Porter-Cable. La ou les pièces présumées défectueuses doivent être renvoyées franco de port à l'usine ou à l'un des centres de service de l'usine Delta. La garantie ne comprend pas les frais de main-d'oeuvre ou de remplacement, de pièce, occasionnés par suite de mauvais usage, dégradation et usure normale, lesquels ne donnent droit ni à remplacement, ni à réparation. Toute réparation effectuée en dehors de notre usine, de nos succursales de service et de nos centres de service autorisés annule la garantie. **IL EST EXPRESSÉMENT PRÉCISÉ QUE NOUS NE SERONS ENGAGÉS PAR AUCUNE AUTRE GARANTIE (EXPRESSE OU TACITE) DE QUALITÉ INTRINSÈQUE, DE QUALITÉ MARCHANDE OU D'APTITUDE À UN EMPLOI PARTICULIER.**

Printed in USA
Imprimé aux É-U.

Free Manuals Download Website

<http://myh66.com>

<http://usermanuals.us>

<http://www.somanuals.com>

<http://www.4manuals.cc>

<http://www.manual-lib.com>

<http://www.404manual.com>

<http://www.luxmanual.com>

<http://aubethermostatmanual.com>

Golf course search by state

<http://golfingnear.com>

Email search by domain

<http://emailbydomain.com>

Auto manuals search

<http://auto.somanuals.com>

TV manuals search

<http://tv.somanuals.com>