

DENON

DJ MIXER / DJ-MIXER / MELANGEUR DJ / DJ MIXER / DJ MIXER /
DJ MIXER / DJ MIXER / DJ 混音台

DN-X1100

Owner's Manual

Bedienungsanleitung

Manuel de l'Utilisateur

Manuale delle istruzioni

Manual del usuario

Gebruiksaanwijzing

Bruksanvisning

操作说明书

SAFETY PRECAUTIONS



CAUTION
RISK OF ELECTRIC SHOCK
DO NOT OPEN



CAUTION:
TO REDUCE THE RISK OF ELECTRIC SHOCK, DO NOT REMOVE COVER (OR BACK). NO USER-SERVICEABLE PARTS INSIDE. REFER SERVICING TO QUALIFIED SERVICE PERSONNEL.

The lightning flash with arrowhead symbol, within an equilateral triangle, is intended to alert the user to the presence of uninsulated "dangerous voltage" within the product's enclosure that may be of sufficient magnitude to constitute a risk of electric shock to persons.

The exclamation point within an equilateral triangle is intended to alert the user to the presence of important operating and maintenance (servicing) instructions in the literature accompanying the appliance.

WARNING:
TO REDUCE THE RISK OF FIRE OR ELECTRIC SHOCK, DO NOT EXPOSE THIS APPLIANCE TO RAIN OR MOISTURE.

CAUTION:

1. Handle the power supply cord carefully

Do not damage or deform the power supply cord. If it is damaged or deformed, it may cause electric shock or malfunction when used. When removing from wall outlet, be sure to remove by holding the plug attachment and not by pulling the cord.

2. Do not open the top cover

In order to prevent electric shock, do not open the top cover. If problems occur, contact your DENON dealer.

3. Do not place anything inside

Do not place metal objects or spill liquid inside the DJ mixer. Electric shock or malfunction may result.

Please, record and retain the Model name and serial number of your set shown on the rating label.

Model No. DN-X1100

Serial No. _____

LABELS:

CAUTION
 TO PREVENT ELECTRIC SHOCK, MATCH WIDE BLADE OF PLUG TO WIDE SLOT, FULLY INSERT.

ATTENTION
 POUR ÉVITER LES CHOCs ÉLECTRIQUES, INTRODUIRE LA LAME LA PLUS LARGE DE LA FICHE DANS LA BORNE CORRESPONDANTE DE LA PRISE ET POUSSER JUSQU' AU FOND.

FCC INFORMATION (For US customers)

1. PRODUCT

This product complies with Part 15 of the FCC Rules. Operation is subject to the following two conditions: (1) this product may not cause harmful interference, and (2) this product must accept any interference received, including interference that may cause undesired operation.

2. IMPORTANT NOTICE: DO NOT MODIFY THIS PRODUCT

This product, when installed as indicated in the instructions contained in this manual, meets FCC requirements. Modification not expressly approved by DENON may void your authority, granted by the FCC, to use the product.

3. NOTE

This product has been tested and found to comply with the limits for a Class B digital device, pursuant to Part 15 of the FCC Rules. These limits are designed to provide reasonable protection against harmful interference in a residential installation.

This product generates, uses and can radiate radio frequency energy and, if not installed and used in accordance with the instructions, may cause harmful interference to radio communications. However, there is no guarantee that interference will not occur in a particular installation. If this product does cause harmful interference to radio or television reception, which can be determined by turning the product OFF and ON, the user is encouraged to try to correct the interference by one or more of the following measures:

- Reorient or relocate the receiving antenna.
- Increase the separation between the equipment and receiver.
- Connect the product into an outlet on a circuit different from that to which the receiver is connected.
- Consult the local retailer authorized to distribute this type of product or an experienced radio/TV technician for help.

This Class B digital apparatus complies with Canadian ICES-003.
 Cet appareil numérique de la classe B est conforme à la norme NMB-003 du Canada.

IMPORTANT SAFETY INSTRUCTIONS

READ BEFORE OPERATING EQUIPMENT

This product was designed and manufactured to meet strict quality and safety standards. There are, however, some installation and operation precautions which you should be particularly aware of.







1. Read these instructions.
2. Keep these instructions.
3. Heed all warnings.
4. Follow all instructions.
5. Do not use this apparatus near water.
6. Clean only with dry cloth.
7. Do not block any ventilation openings. Install in accordance with the manufacture's instructions.
8. Do not install near any heat sources such as radiators, heat registers, stoves, or other apparatus (including amplifiers) that produce heat.
9. Do not defeat the safety purpose of the polarized or grounding-type plug. A polarized plug has two blades with one wider than the other. A grounding type plug has two blades and a third grounding prong. The wide blade or the third prong are provided for your safety. If the provided plug does not fit into your outlet, consult an electrician for replacement of the obsolete outlet.
10. Protect the power cord from being walked on or pinched particularly at plugs, convenience receptacles, and the point where they exit from the apparatus.
11. Only use attachments/accessories specified by the manufacturer.
12. Use only with the cart, stand, tripod, bracket, or table specified by the manufacturer, or sold with the apparatus. When a cart is used, use caution when moving the cart/apparatus combination to avoid injury from tip-over.
13. Unplug this apparatus during lightning storms or when unused for long periods of time.
14. Refer all servicing to qualified service personnel. Servicing is required when the apparatus has been damaged in any way, such as power-supply cord or plug is damaged, liquid has been spilled or objects have fallen into the apparatus, the apparatus has been exposed to rain or moisture, does not operate normally, or has been dropped.

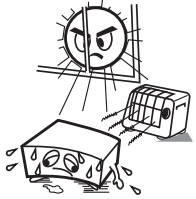
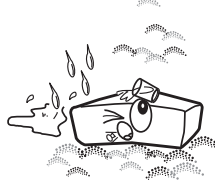

Additional Safety Information!

15.  Marked terminals are HAZARDOUS LIVE and that the external wiring connected to those terminal requires installation by an instructed person or the use of ready-made leads or cords.

NOTE ON USE / HINWEISE ZUM GEBRAUCH / OBSERVATIONS RELATIVES A L'UTILISATION / NOTE SULL'USO / NOTAS SOBRE EL USO / ALVORENS TE GEBRUIKEN / OBSERVERA ANGÅENDE ANVÄNDNINGEN

 <ul style="list-style-type: none"> • Avoid high temperatures. Allow for sufficient heat dispersion when installed in a rack. • Vermeiden Sie hohe Temperaturen. Beachten Sie, dass eine ausreichende Belüftung gewährleistet wird, wenn das Gerät auf ein Regal gestellt wird. • Eviter des températures élevées. Tenir compte d'une dispersion de chaleur suffisante lors de l'installation sur une étagère. • Evitate di esporre l'unità a temperature elevate. Assicuratevi che vi sia un'adeguata dispersione del calore quando installate l'unità in un mobile per componenti audio. • Evite altas temperaturas. Permite la suficiente dispersión del calor cuando está instalado en la consola. • Vermijd hoge temperaturen. Zorg er bij installatie in een audiorack voor, dat de door het toestel geproduceerde warmte goed kan worden afgevoerd. • Undvik höga temperaturer. Se till att det finns möjlighet till god värmeavledning vid montering i ett rack. 	 <ul style="list-style-type: none"> • Keep the unit free from moisture, water, and dust. • Halten Sie das Gerät von Feuchtigkeit, Wasser und Staub fern. • Protéger l'appareil contre l'humidité, l'eau et la poussière. • Tenete l'unità lontana dall'umidità, dall'acqua e dalla polvere. • Mantenga el equipo libre de humedad, agua y polvo. • Laat geen vochtigheid, water of stof in het apparaat binnendringen. • Utsätt inte apparaten för fukt, vatten och damm. 	 <ul style="list-style-type: none"> • Do not let foreign objects into the unit. • Lassen Sie keine fremden Gegenstände in das Gerät kommen. • Ne pas laisser des objets étrangers dans l'appareil. • Non inserire corpi estranei all'interno dell'unità. • No deje objetos extraños dentro del equipo. • Laat geen vreemde voorwerpen in dit apparaat vallen. • Se till att främmande föremål inte tränger in i apparaten.
 <ul style="list-style-type: none"> • Handle the power cord carefully. Hold the plug when unplugging the cord. • Gehen Sie vorsichtig mit dem Netzkabel um. Halten Sie das Kabel am Stecker, wenn Sie den Stecker herausziehen. • Manipuler le cordon d'alimentation avec précaution. Tenir la prise lors du débranchement du cordon. • Maneggiare il cavo di alimentazione con attenzione. Tenete ferma la spina quando scollegate il cavo dalla presa. • Maneje el cordón de energía con cuidado. Sostenga el enchufe cuando desconecte el cordón de energía. • Hanteer het netsnoer voorzichtig. Houd het snoer bij de stekker vast wanneer deze moet worden aan- of losgekoppeld. • Hantera nätkabeln varsamt. Håll i kabeln när den kopplas från eluttaget. 	 <ul style="list-style-type: none"> • Unplug the power cord when not using the unit for long periods of time. • Wenn das Gerät längere Zeit nicht verwendet werden soll, trennen Sie das Netzkabel vom Netzstecker. • Débrancher le cordon d'alimentation lorsque l'appareil n'est pas utilisé pendant de longues périodes. • Scollegate il cavo di alimentazione quando prevedete di non utilizzare l'unità per un lungo periodo di tempo. • Desconecte el cordón de energía cuando no utilice el equipo por mucho tiempo. • Neem altijd het netsnoer uit het stopcontact wanneer het apparaat gedurende een lange periode niet wordt gebruikt. • Koppla loss nätkabeln om apparaten inte kommer att användas i lång tid. 	 <ul style="list-style-type: none"> • Do not let insecticides, benzene, and thinner come in contact with the unit. • Lassen Sie das Gerät nicht mit Insektiziden, Benzin oder Verdünnungsmitteln in Berührung kommen. • Ne pas mettre en contact des insecticides, du benzène et un diluant avec l'appareil. • Assicuratevi che l'unità non entri in contatto con insetticidi, benzolo o solventi. • No permita el contacto de insecticidas, gasolina y diluyentes con el equipo. • Voorkom dat insecticiden, benzeen of ververdunner met dit toestel in contact komen. • Se till att inte insektsmedel på spraybruk, bensen och thinner kommer i kontakt med apparatens hölje.
 <ul style="list-style-type: none"> • Do not obstruct the ventilation holes. • Decken Sie den Lüftungsbereich nicht ab. • Ne pas obstruer les trous d'aération. • Non coprite i fori di ventilazione. • No obstruya los orificios de ventilación. • De ventilatieopeningen mogen niet worden beblokkeerd. • Täpp inte till ventilationsöppningarna. 	<p>* (For apparatuses with ventilation holes)</p> <ul style="list-style-type: none"> • Never disassemble or modify the unit in any way. • Versuchen Sie niemals das Gerät auseinander zu nehmen oder zu verändern. • Ne jamais démonter ou modifier l'appareil d'une manière ou d'une autre. • Non smontate né modificate l'unità in alcun modo. • Nunca desarme o modifique el equipo de ninguna manera. • Dit toestel mag niet gedemonteerd of aangepast worden. • Ta inte isär apparaten och försök inte bygga om den. 	

CAUTION:

- The ventilation should not be impeded by covering the ventilation openings with items, such as newspapers, tablecloths, curtains, etc.
- No naked flame sources, such as lighted candles, should be placed on the unit.
- Observe and follow local regulations regarding battery disposal.
- Do not expose the unit to dripping or splashing fluids.
- Do not place objects filled with liquids, such as vases, on the unit.

ACHTUNG:

- Die Belüftung sollte auf keinen Fall durch das Abdecken der Belüftungsöffnungen durch Gegenstände wie beispielsweise Zeitungen, Tischtücher, Vorhänge o. Ä. behindert werden.
- Auf dem Gerät sollten keinerlei direkte Feuerquellen wie beispielsweise angezündete Kerzen aufgestellt werden.
- Bitte beachten Sie bei der Entsorgung der Batterien die örtlich geltenden Umweltbestimmungen.
- Das Gerät sollte keiner tropfenden oder spritzenden Flüssigkeit ausgesetzt werden.
- Auf dem Gerät sollten keine mit Flüssigkeit gefüllten Behälter wie beispielsweise Vasen aufgestellt werden.

ATTENTION:

- La ventilation ne doit pas être gênée en recouvrant les ouvertures de la ventilation avec des objets tels que journaux, rideaux, tissus, etc.
- Aucune flamme nue, par exemple une bougie, ne doit être placée sur l'appareil.
- Veillez à respecter les lois en vigueur lorsque vous jetez les piles usagées.
- L'appareil ne doit pas être exposé à l'eau ou à l'humidité.
- Ne pas poser d'objet contenant du liquide, par exemple un vase, sur l'appareil.

ATTENZIONE:

- Le aperture di ventilazione non devono essere ostruite coprendole con oggetti, quali giornali, tovaglie, tende e così via.
- Non posizionate sull'unità fiamme libere, come ad esempio candele accese.
- Prestate attenzione agli aspetti legati alla tutela dell'ambiente nello smaltimento delle batterie.
- L'apparecchiatura non deve essere esposta a gocciolii o spruzzi.
- Non posizionate sull'unità alcun oggetto contenente liquidi, come ad esempio i vasi.

PRECAUCIÓN:

- La ventilación no debe quedar obstruida por haberse cubierto las aperturas con objetos como periódicos, manteles, cortinas, etc.
- No debe colocarse sobre el aparato ninguna fuente inflamable sin protección, como velas encendidas.
- A la hora de deshacerse de las pilas, respete la normativa para el cuidado del medio ambiente.
- No exponer el aparato al goteo o salpicaduras cuando se utilice.
- No colocar sobre el aparato objetos llenos de líquido, como jarras.

WAARSCHUWING:

- De ventilatie mag niet worden belemmerd door de ventilatieopeningen af te dekken met bijvoorbeeld kranten, een tafelkleed, gordijnen, enz.
- Plaats geen open vlammen, bijvoorbeeld een brandende kaars, op het apparaat.
- Houd u steeds aan de milieuvoorschriften wanneer u gebruikte batterijen wegdoet.
- Stel het apparaat niet bloot aan druppels of spatten.
- Plaats geen voorwerpen gevuld met water, bijvoorbeeld een vaas, op het apparaat.

OBSERVERA:

- Ventilationsbör inte förhindras genom att täcka för ventilationsöppningarna med föremål såsom tidningar, bordsdukar, gardiner osv.
- Inga blottade brandkällor, såsom tända ljus, får placeras på apparaten.
- Tänk på miljöaspekterna när du bortskaffar batterier.
- Apparaten får inte utsättas för vätska.
- Placera inte föremål fyllda med vätska, t.ex. vasor, på apparaten.

DECLARATION OF CONFORMITY

We declare under our sole responsibility that this product, to which this declaration relates, is in conformity with the following standards: EN60065, EN55013, EN55020, EN61000-3-2 and EN61000-3-3. Following the provisions of 2006/95/EC and 2004/108/EC Directive.

ÜBEREINSTIMMUNGSERKLÄRUNG

Wir erklären unter unserer Verantwortung, daß dieses Produkt, auf das sich diese Erklärung bezieht, den folgenden Standards entspricht: EN60065, EN55013, EN55020, EN61000-3-2 und EN61000-3-3. Entspricht den Verordnungen der Direktive 2006/95/EC und 2004/108/EC.

DECLARATION DE CONFORMITE

Nous déclarons sous notre seule responsabilité que l'appareil, auquel se réfère cette déclaration, est conforme aux standards suivants: EN60065, EN55013, EN55020, EN61000-3-2 et EN61000-3-3. D'après les dispositions de la Directive 2006/95/EC et 2004/108/EC.

DICHIARAZIONE DI CONFORMITÀ

Dichiariamo con piena responsabilità che questo prodotto, al quale la nostra dichiarazione si riferisce, è conforme alle seguenti normative: EN60065, EN55013, EN55020, EN61000-3-2 e EN61000-3-3. In conformità con le condizioni delle direttive 2006/95/EC e 2004/108/EC. QUESTO PRODOTTO E' CONFORME AL D.M. 28/08/95 N. 548

DECLARACIÓN DE CONFORMIDAD

Declaramos bajo nuestra exclusiva responsabilidad que este producto al que hace referencia esta declaración, está conforme con los siguientes estándares: EN60065, EN55013, EN55020, EN61000-3-2 y EN61000-3-3. Siguiendo las provisiones de las Directivas 2006/95/EC y 2004/108/EC.

EENVORMIGHEIDSVERKLARING

Wij verklaren uitsluitend op onze verantwoordelijkheid dat dit product, waarop deze verklaring betrekking heeft, in overeenstemming is met de volgende normen: EN60065, EN55013, EN55020, EN61000-3-2 en EN61000-3-3. Volgens de bepalingen van de Richtlijnen 2006/95/EC en 2004/108/EC.

ÖVERENSSTÄMMELSESINTYG

Härmed intygas helt på eget ansvar att denna produkt, vilken detta intyg avser, uppfyller följande standarder: EN60065, EN55013, EN55020, EN61000-3-2 och EN61000-3-3. Enligt stadgarna i direktiv 2006/95/EC och 2004/108/EC.

A NOTE ABOUT RECYCLING:

This product's packaging materials are recyclable and can be reused. Please dispose of any materials in accordance with the local recycling regulations.

When discarding the unit, comply with local rules or regulations.

Batteries should never be thrown away or incinerated but disposed of in accordance with the local regulations concerning battery disposal.

This product and the supplied accessories, excluding the batteries, constitute the applicable product according to the WEEE directive.

HINWEIS ZUM RECYCLING:

Das Verpackungsmaterial dieses Produktes ist zum Recyceln geeignet und kann wieder verwendet werden. Bitte entsorgen Sie alle Materialien entsprechend der örtlichen Recycling-Vorschriften.

Beachten Sie bei der Entsorgung des Gerätes die örtlichen Vorschriften und Bestimmungen.

Die Batterien dürfen nicht in den Hausmüll geworfen oder verbrannt werden; bitte entsorgen Sie die Batterien gemäß der örtlichen Vorschriften.

Dieses Produkt und das im Lieferumfang enthaltene Zubehör (mit Ausnahme der Batterien!) entsprechen der WEEE-Direktive.

UNE REMARQUE CONCERNANT LE RECYCLAGE:

Les matériaux d'emballage de ce produit sont recyclables et peuvent être réutilisés. Veuillez disposer des matériaux conformément aux lois sur le recyclage en vigueur.

Lorsque vous mettez cet appareil au rebut, respectez les lois ou réglementations en vigueur.

Les piles ne doivent jamais être jetées ou incinérées, mais mises au rebut conformément aux lois en vigueur sur la mise au rebut des piles.

Ce produit et les accessoires inclus, à l'exception des piles, sont des produits conformes à la directive DEEE.

NOTA RELATIVA AL RICICLAGGIO:

I materiali di imballaggio di questo prodotto sono riutilizzabili e riciclabili. Smaltire i materiali conformemente alle normative locali sul riciclaggio.

Per lo smaltimento dell'unità, osservare le normative o le leggi locali in vigore.

Non gettare le batterie, né incenerirle, ma smaltirle conformemente alla normativa locale sui rifiuti chimici.

Questo prodotto e gli accessori inclusi nell'imballaggio sono applicabili alla direttiva RAEE, ad eccezione delle batterie.

ACERCA DEL RECICLAJE:

Los materiales de embalaje de este producto son reciclables y se pueden volver a utilizar. Disponga de estos materiales siguiendo los reglamentos de reciclaje de su localidad.

Cuando se deshaga de la unidad, cumpla con las reglas o reglamentos locales.

Las pilas nunca deberán tirarse ni incinerarse. Deberá disponer de ellas siguiendo los reglamentos de su localidad relacionados con los desperdicios químicos.

Este producto junto con los accesorios empaquetados es el producto aplicable a la directiva RAEE excepto pilas.

EEN AANTEKENING MET BETREKKING TOT DE RECYCLING:

Het inpakmateriaal van dit product is recycleerbaar en kan opnieuw gebruikt worden. Er wordt verzocht om zich van elk afvalmateriaal te ontdoen volgens de plaatselijke voorschriften.

Volg voor het wegdoen van de speler de voorschriften voor de verwijdering van wit- en bruingoed op.

Batterijen mogen nooit worden weggegooid of verbrand, maar moeten volgens de plaatselijke voorschriften betreffende chemisch afval worden verwijderd.

Op dit product en de meegeleverde accessoires, m.u.v. de batterijen is de richtlijn voor afgedankte elektrische en elektronische apparaten (WEEE) van toepassing.

OBSERVERA ANGÅENDE ÅTERVINNING:

Produktens emballage är återvinningsbart och kan återanvändas. Kassera det enligt lokala återvinningsbestämmelser.

När du kasserar enheten ska du göra det i överensstämmelse med lokala regler och bestämmelser.

Batterier får absolut inte kastas i soporna eller brännas. Kassera dem enligt lokala bestämmelser för kemiskt avfall.

Denna apparat och de tillbehör som levereras med den uppfyller gällande WEEE-direktiv, med undantag av batterierna.



Pb

CAUTION:

To completely disconnect this product from the mains, disconnect the plug from the wall socket outlet.

The mains plug is used to completely interrupt the power supply to the unit and must be within easy access by the user.

VORSICHT:

Um dieses Gerät vollständig von der Stromversorgung abzutrennen, ziehen Sie bitte den Stecker aus der Wandsteckdose.

Der Netzstecker wird verwendet, um die Stromversorgung zum Gerät völlig zu unterbrechen; er muss für den Benutzer gut und einfach zu erreichen sein.

PRECAUTION:

Pour déconnecter complètement ce produit du courant secteur, débranchez la prise de la prise murale. La prise secteur est utilisée pour couper complètement l'alimentation de l'appareil et l'utilisateur doit pouvoir y accéder facilement.

ATTENZIONE:

Per scollegare completamente questo prodotto dalla rete di alimentazione elettrica, scollegare la spina dalla relativa presa a muro.

La spina di rete viene utilizzata per interrompere completamente l'alimentazione all'unità e deve essere facilmente accessibile all'utente.

PRECAUCIÓN:

Para desconectar completamente este producto de la alimentación eléctrica, desconecte el enchufe del enchufe de la pared.

El enchufe de la alimentación eléctrica se utiliza para interrumpir por completo el suministro de alimentación eléctrica a la unidad y debe de encontrarse en un lugar al que el usuario tenga fácil acceso.

WAARSCHUWING:

Om de voeding van dit product volledig te onderbreken moet de stekker uit het stopcontact worden getrokken.

De netstekker wordt gebruikt om de stroomtoevoer naar het toestel volledig te onderbreken en moet voor de gebruiker gemakkelijk bereikbaar zijn.

FÖRSIKTIHETSMÅTT:

Koppla loss stickproppen från eluttaget för att helt skilja produkten från nätet.

Stickproppen används för att helt bryta strömförsörjningen till apparaten, och den måste vara lättillgänglig för användaren.

Contents

Getting Started

Accessories 1

Installation 1

Main Features 1

Part Names and Functions 2

 Top Panel 2

 Rear Panel 4

Connections

Preparations 5

 Cables Used for Connections 5

Fader Start

Connections 6

Channel Fader Start 7

Crossfader Start 7

Replacing the Crossfader 7

Replacing the Channel Fader 8

Flex Fader Crossfader Slide Torque Adjustment Procedure 8

Specifications 9

Getting Started

Accessories

Check that the following parts are supplied with the product.

- ① Owner's manual 1
- ② Connection cable
(3.5 mm stereo mini cable, Cord length: Approx. 1 m) 2
- ③ Audio cable (Cord length: Approx. 1 m) 2
- ④ Power cord (Cord length: Approx. 1.8 m) 1

Installation

When the DN-X1100 is mounted inside a coffin or DJ booth, we recommend leaving a 2 cm (Bottom 1.5 mm) blank space above the mixer if possible.

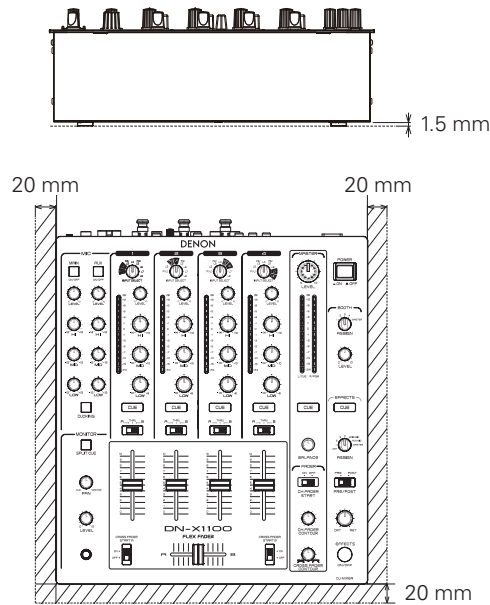

Main Features

CONGRATULATIONS! You have purchased the DENON DN-X1100 DJ mixer from D&M HOLDINGS Inc.

- 1. Input Select (Matrix input select)**
8 input sources are freely assignable to each channel.
- 2. 60 MM Channel Fader (Replaceable)**
60 mm long-stroke channel fader for precise adjustment of the volume.
- 3. Level Meter per Channel**
Easily visible 13-dot level meters for each channel.
- 4. Booth Assign**
1 ch – 4 ch and master Selects the source of the BOOTH output.
- 5. Enhanced SEND/RETURN terminals**
8 LINE, 3 PHONO, 2 Microphone systems, 2 MASTER outputs, BOOTH output and REC output are provided independently. Effect SEND/RETURN terminals are also provided for an external effects processor.
- 6. 3-Band Equalizer**
LOW, MID, HI and GAIN controls are available on every input channel (Kill type equalizer).
- 7. Crossfader Contour**
This feature allows adjusting the "shape" of the Crossfader response from a gentle curve for smooth, long running fades, to the steep pitch required for top performance cut and scratch effects.
- 8. Channel Fader and Crossfader Start**
The CD player can be started or stopped simply by increasing or decreasing the level of the Ch. Fader or by using the Crossfader left to right or right to left. (This function can only be used when the DENON CD players DN-S3500 or etc. is connected to the DN-X1100)
- 9. Hi-Grade Type Op Amp**
The input/output section uses a hi-grade type op amp for high sound quality.
- 10. FLEX FADER (Adjustable Slide Torque Crossfader.)**
The crossfader's slide torque can be adjusted to achieved the desired feeling.

Part Names and Functions

Top Panel

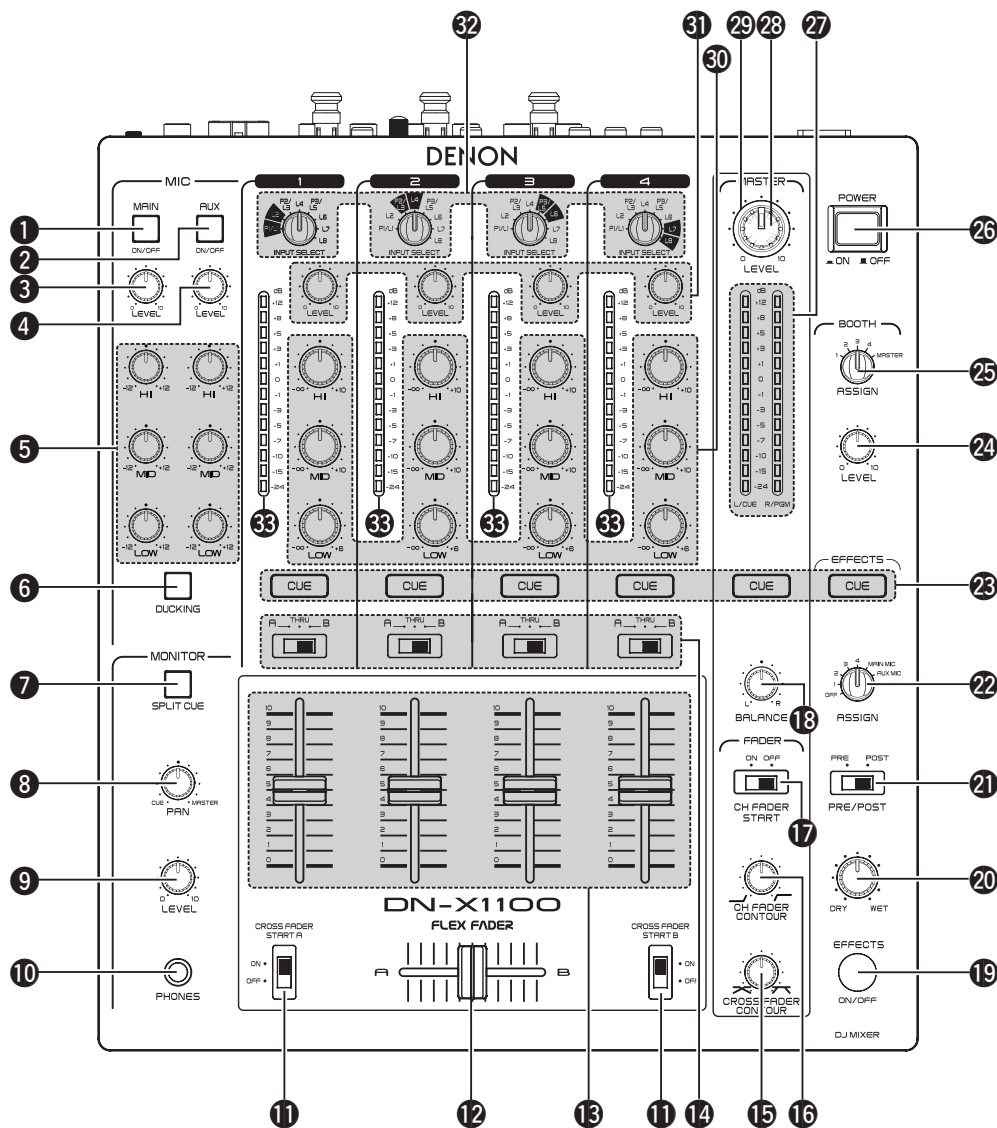

1 MAIN MIC ON/OFF button

When the button is lit, Main Mic signal is transferred to output section, otherwise Main Mic input is muted.

2 AUX MIC ON/OFF button

When the button is lit, Aux Mic signal is transferred to output section, otherwise Aux Mic input is muted.

3 MAIN MIC LEVEL control

Adjusts the level of the Main Mic input.

4 AUX MIC LEVEL control

Adjusts the level of the Aux Mic input.

5 MIC EQ controls

Contour the frequency response of the Mic input -12 dB to +12 dB.

HI

Adjusts high-tone Mic sound -12 dB to +12 dB. At the center position, sound is flat.

MID

Adjusts mid-tone Mic sound -12 dB to +12 dB. At the center position, sound is flat.

LOW

Adjusts low-tone Mic sound -12 dB to +12 dB. At the center position, sound is flat.

6 DUCKING ON/OFF button

- Use this to switch the Talk Over function ON and OFF. (ON/OFF is cyclic)
- When the button is lit, level of signals except Mics is attenuated.
- The DUCKING attenuation level adjusts. See below rear panel 9 (page 4).

7 SPLIT CUE button

- In the STEREO mode, this button feeds STEREO Program (CUE MASTER) and Cue to both earcups, in the SPLIT CUE (MONO) mode, the headphone circuit provides MONO Cue to the left ear and MONO Program (MASTER) to the right.
- In the STEREO mode, the meter indicates the stereo level in the LEFT and RIGHT Master Outputs. In the SPLIT CUE (MONO) mode, mono Cue level is displayed on the Left meter and mono Program (CUE MASTER) level is displayed on the Right meter.
- In the SPLIT CUE (MONO) mode, the button is lit.

8 HEADPHONE PAN control

Serves two purposes... In the STEREO mode it changes the relative levels of the Cue and Program mixed together in both ear cups. In the MONO mode it changes the balance between the Mono Cue in the left ear cup and the Mono Program in the right.

9 HEADPHONE level control

Adjusts the volume for the headphones.

10 HEADPHONE output jack

Accepts 1/4" stereo headphone plugs.

11 CROSSFADER START A, B switches

Use this to switch the Crossfader Start function ON and OFF.

12 CROSSFADER

Controls the relative output level from the summed A and B Mixes. When the fader is at its far left, only the A Mix is heard from the Outputs. As the fader is moved toward the right, the amount of B Mix is increased and the amount of A Mix is decreased. When the fader is centered, equal amounts of A and B Mixes are routed to the Outputs. Fully right is all B Mix at the Outputs.

• LINE 2, 4, 6, 8 FADER output terminals

- (Rear Panel 8 (page 4))
- ø 3.5 mm stereo mini terminal
- Others should not be affected a terminal short-circuit.

13 Source input fader (Ch. fader)

Controls the level of the selected Input.

14 CROSSFADER ASSIGN switches

- A, B:** The channel source is assigned to A or B of the Crossfader.
- THRU:** Select when you don't assign the channel source into the Crossfader.

15 CROSSFADER CONTOUR control

Allows adjusting the “shape” of the Crossfader response from a gentle curve for smooth, long running fades, to the steep pitch required for top performance cut and scratch effects.

16 CH FADER CONTOUR control

Adjusts the volume curve response of the channel fader.

17 CH FADER START switch

This function will start the performance of CD player with Ch. Fader automatically is on/off.

FADER START

If the separately sold DN-S1200, DN-S3500, DN-HS5500 and etc. players are connected to LINE2, 4, 6 or 8, they can be started using the source input fader (Ch. Fader) or Crossfader, as long as the 3.5 mm stereo mini cords have been connected.

18 MASTER BALANCE control

Adjusts the L/R balance of the MASTER output.

19 EFFECTS ON/OFF button

- Routes the assigned signal through the external processor attached to the SEND/RETURN connectors on the rear.
- When the EFFECT is ON, the button is lit.
- The effect button is flashing when there is no connection of the effects.

20 EFFECTS WET/DRY control

Use this to adjust the ratio of original and effected sound.

21 PRE/POST switch (EFFECTS)

Use this to select pre-fader or post-fader.

22 EFFECTS ASSIGN switch

Use this to select the source of the external processor.

23 CUE buttons

Pressing in any or all of **CUE** buttons routes the respective source to the headphone and meter cue sections. Pressing multiple buttons makes it possible to derive mixed sound from the selected sources.

24 BOOTH LEVEL control

Adjusts the level of the BOOTH outputs.

25 BOOTH ASSIGN switch

Selects the source of the BOOTH output.

26 POWER switch

Press the switch to turn the power on.

27 Peak dB CUE/PROGRAM meter

- Displays the output level following Master Level adjustment, the peak level is held for 1 second. Display range: -24 dB to +12 dB.
- Can switch between two display modes. See below **7**, **8**.

28 MASTER LEVEL control

Adjusts the level of the MASTER outputs.

29 POWER indicator

When the red indicator is lit, the DN-X1100 is ready to go.

30 Source EQ controls

Use VRs with center detent for equaliser.

HI

Adjusts the high-tone sound -33 dB to +10 dB. At the center position, sound is flat.

MID

Adjusts the mid-tone sound -35 dB to +10 dB. At the center position, sound is flat.

LOW

Adjusts the low-tone sound -35 dB to +6 dB. At the center position, sound is flat.

31 LEVEL controls

Adjusts the level of the selected input - ∞ to +15 dB.

32 SOURCE INPUT SELECT switches (Input selectors)

- Select any source from eight inputs (PHONO1/LINE1, LINE2, PHONO2/LINE3, LINE4, PHONO3/LINE5, LINE6, LINE7, LINE8) for each channel independently.
- You also can assign the same input to several channels for creative mixing.

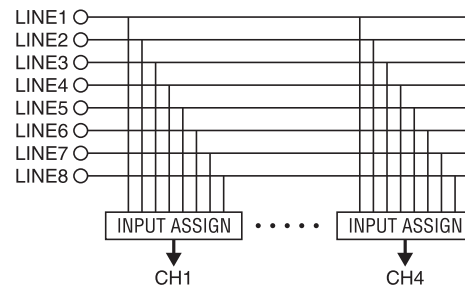
**33 CH LEVEL meter**

Display range: -24 dB to +12 dB.

Displays the input level after adjusted with LEVEL **31** and Source EQ **30** controls.

Rear Panel

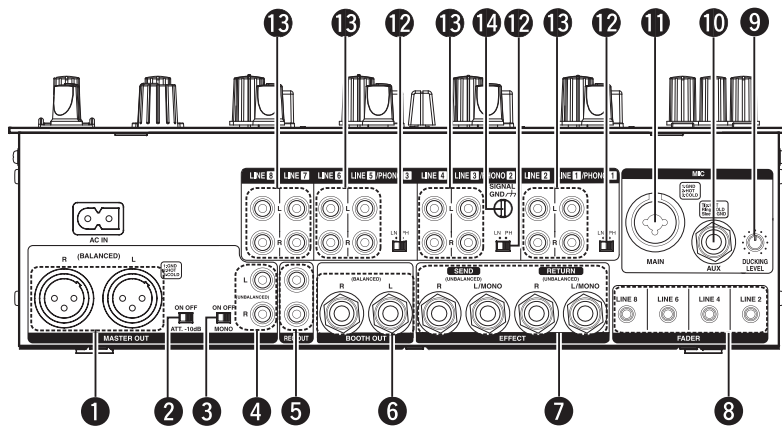
**1 MAIN OUT (BALANCED) connectors**

- These XLR type connectors provide a balanced line level output.
- Connect these connectors to the balanced analog input connectors on an amplifier or console.
- Pin layout: 1. GND, 2. Hot, 3. Cold
- Applicable connector: Cannon XLR-3-31 or equivalent.

2 LEVEL ATT (Master out level attenuator)

- Use this to attenuate the MASTER output level (-10 dB).
- Reference is 0 dB.

3 MASTER MONO OUT ON/OFF switch

When this switch is on, mixed L and R signal is outputted from the MASTER OUT.

4 MAIN OUT (UNBALANCED) terminals

- This stereo pair of RCA terminals provides a unbalanced line level output.
- Connect these terminals to the unbalanced analog input terminals on an amplifier or console.

5 REC OUT terminals

- This stereo pair of RCA terminals provides a line level output. The signal is unaffected by the Master Level control.
- It is intended for use with a tape recorder, but is not restricted to that purpose.

6 BOOTH OUT (BALANCED) connectors

- These 1/4" TRS type connectors provide a balanced line level output with independent front panel Zone Level controls and are not affected by the Master Level control.
- Connect these connectors to the balanced analog input connectors on an amplifier or console.
- Pin layout: Tip: Hot, Ring: Cold, Sleeve: GND
- Applicable connector: Cannon XLR-3-31 or equivalent.

7 SEND/RETURN terminals

- These 1/4" TS mono terminals allow external processing of the program signal.
- When connect monaural type effect processor, use Lch input and output.

8 LINE 2, 4, 6, 8 FADER output terminals

Connect these terminals to the Fader input terminals of the DN-S1200, DN-S3500, DN-HS5500 and etc using the 3.5 mm stereo mini cord.

9 DUCKING ATTENUATION LEVEL control

DUCKING attenuation level can be adjusted. (-∞ ~ -20 dB)

10 AUX MIC input terminal

Accepts a balanced microphone with 1/4" terminals.

11 MAIN MIC input terminal

- Neutric combo terminal.
- Accepts either a balanced microphone with an XLR connector or a balanced microphone with 1/4" TRS balanced terminals.

12 PHONO 1, 2, 3 /LINE 1, 3, 5 switches

- These switches change the Input from Phono to Line level inputs.
- These switches set Line level inputs when Turntable is not connected.

13 PHONO 1, 2, 3 /LINE 1, 2, 3, 4, 5, 6, 7, 8 input terminals

These stereo pairs of unbalanced RCA terminals are Inputs for any line level device.

14 Phono Ground screws

This screws provide a place to connect the ground wire from a turntable. This terminal is exclusively for a turntable grounding and not a safety earth ground.

Connections

Refer to the Connection Diagram below.

1. Make certain AC power is off while making connections.
2. Quality cables make a big difference in fidelity and punch. Use high-quality, audio cables.
3. Do not use excessively long cables. Be sure plugs and terminals are securely fastened. Loose connections cause hum, noise, or intermittence that could damage your speakers.
4. Connect all stereo input sources. Then connect any effects into the stereo Effect, if used. Connect your Microphone(s) and monitor headphones. Make sure all faders are at "zero" and the unit is off. Take care to connect only one cable at a time. pay attention to L and R position of terminals, on both the DN-X1100 and outboard gear.
5. Connect the stereo outputs to the power amplifier(s) and/or tape deck(s) and/or MD recorder(s) and/or CD recorder(s). Plug the DN-X1100 into AC power outlet.

NOTE

- Always switch on your audio input sources such as CD players first, then your mixer, and finally any amplifiers.
- When turning off, always reverse this operation by turning off amplifiers, then your mixer, and then input units.

Preparations

Cables Used for Connections

Select the cables according to the equipment being connected.

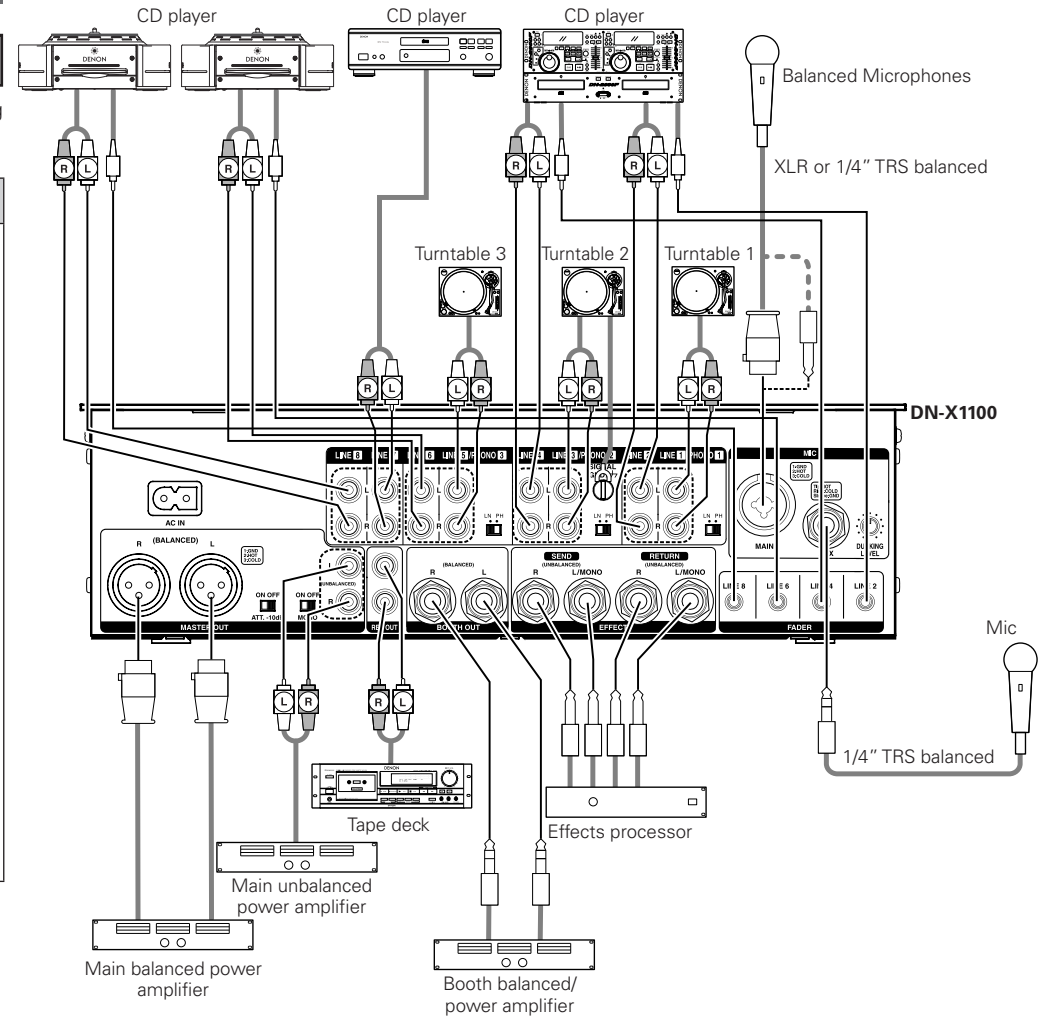
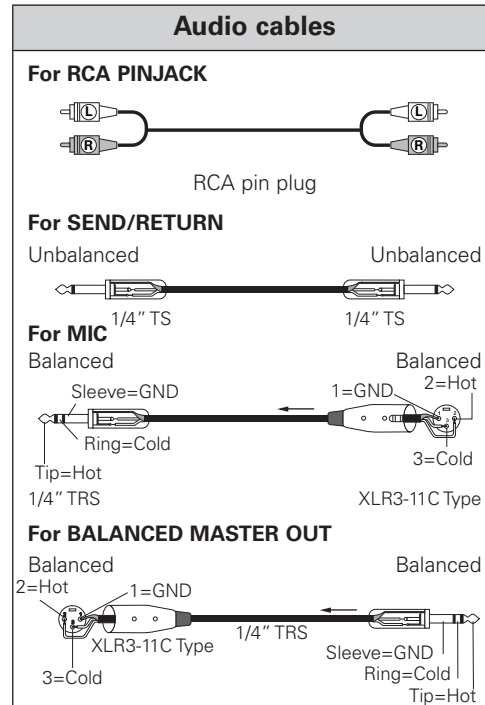

NOTE

Keep volume at comfortable sound levels and avoid extended play at very high volume as it may cause temporary or permanent hearing loss.

Fader Start

Connections

If the separately sold DN-S3500 and etc. players are connected to LINE2, 4, 6 or 8, they can be started using the source input fader (Ch. Fader) or Crossfader, as long as the 3.5 mm stereo mini cords have been connected.

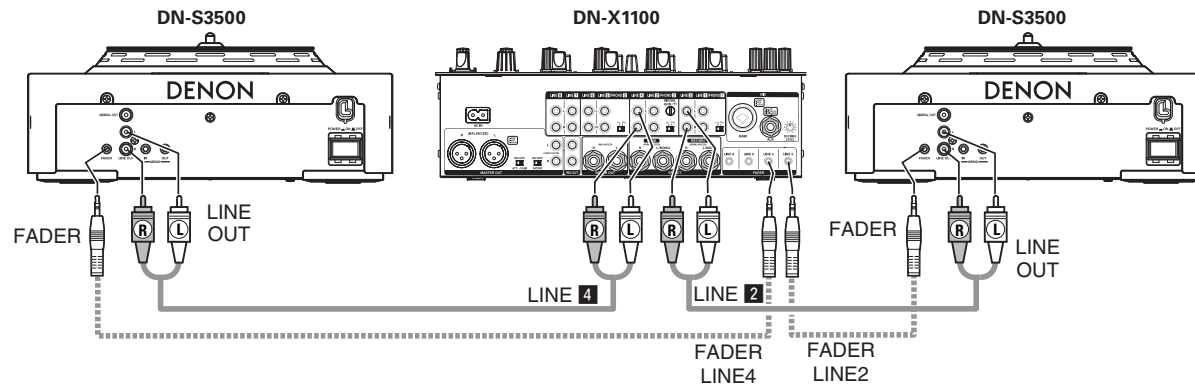

Channel Fader Start

- 1 Turn the **INPUT ASSIGN** switch to select the desired source from LINE2, 4, 6 or 8.
- 2 Turn on the **CH FADER START** switch.
※ **CROSS FADER ASSIGN** position is "THUR".
- 3 Move the source input fader (**Ch. Fader**) of CH-1, CH-2, CH-3 or CH-4 control all the way to the bottom.
- 4 Set the standby mode on CD player.
- 5 Use the **CH FADER CONTOUR** control to control the channel fader startup curve.
- 6 When you want to start the player, move up the source input fader (**Ch. Fader**) and the CD player will begin playing.

Source input fader (Ch. Fader) CH FADER CONTOUR

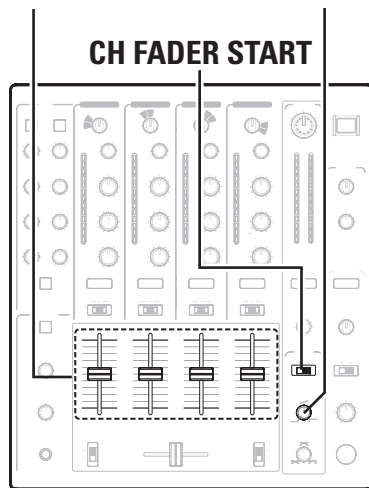

Crossfader Start

- 1 Turn the **INPUT ASSIGN** switch to select the desired source from LINE2, 4, 6 or 8.
- 2 Using the **CROSSFADER ASSIGN** switch, assign the channel or Sampler source into A or B of Crossfader.
- 3 Turn on the **CROSSFADER START A, B** switches.
- 4 Slide the **Crossfader** all the way in direction opposite the source you want to start. (In the following example, startup is done with the CD player connected set to Assign A.)
- 5 Set the standby mode on CD player.
- 6 Use the **CROSSFADER CONTOUR** control to control the cross fader startup curve.
- 7 When the **Crossfader** is slid in the opposite direction, CD player play will begin.

CROSSFADER ASSIGN

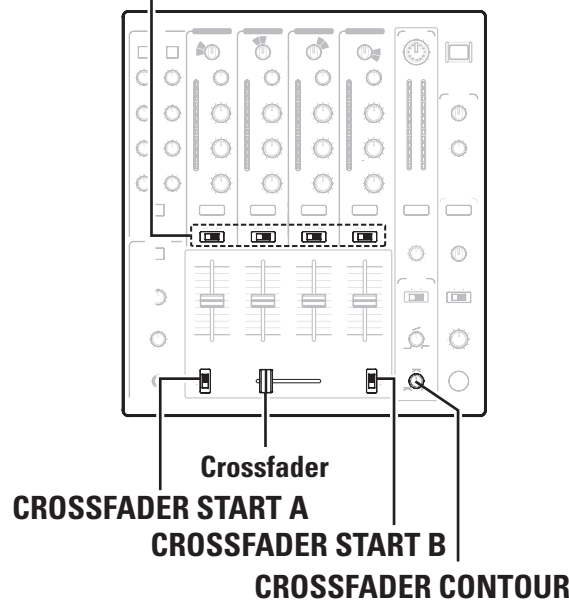

Replacing the Crossfader

The Crossfader may be removed without disassembly of DN-X1100 itself.

- 1 Pull out the **Crossfader knob**.
- 2 Removed the five outer screws (A) attaching the crossfader plate.
- 3 Remove the two screws (B) attaching the crossfader bracket assembly from chassis.
- 4 Pull the crossfader bracket assembly forward and unplug the 3P cable from the connector on the panel board.

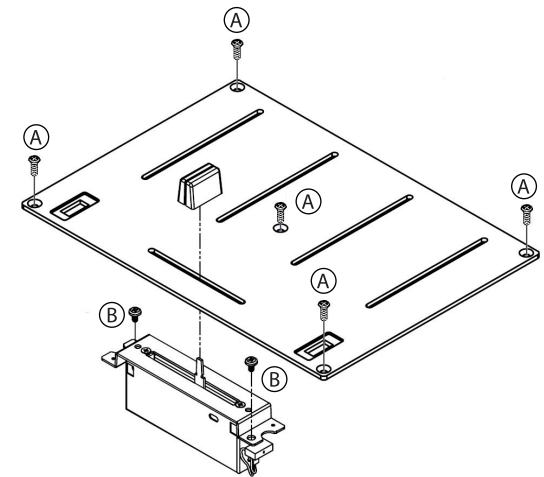

Replacing the Channel Fader

The Channel fader may be removed without any disassembly of the DN-X1100 itself.

- 1** Pull out the **Channel fader knob**.
- 2** Remove the five outer screws **(A)** attaching the channel fader plate and channel fader bracket assembly from the front panel.
- 3** Remove the two screws **(B)** attaching the channel fader bracket assembly from chassis.
- 4** Pull the channel fader bracket assembly forward and unplug the 4P cable from the connector on the channel fader printing board.
- 5** Install the replacement assembly by reversing above instructions.

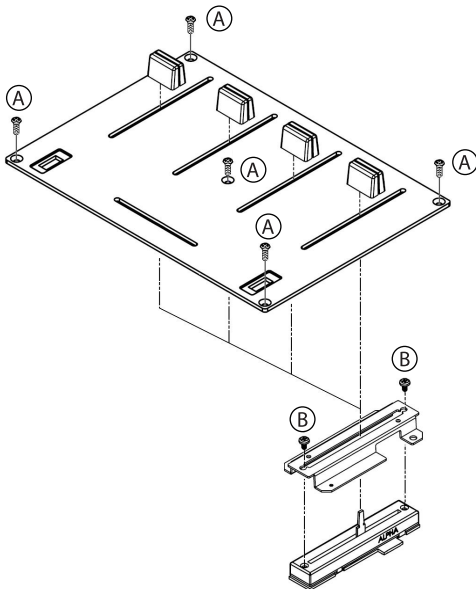

Flex Fader Crossfader Slide Torque Adjustment Procedure

- 1** Follow the procedure at “Replacing the Crossfader” to remove the **Crossfader** from the set.
- 2** Move the lever so that the head of the **Screw** is positioned at the hole in the case.
- 3** Turn the **Screw** using a screwdriver, move the lever and adjust to the desired torque.
- 4** Reinstall the **Crossfader** following the removal procedure in reverse order.

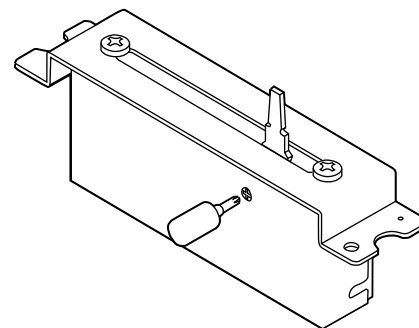
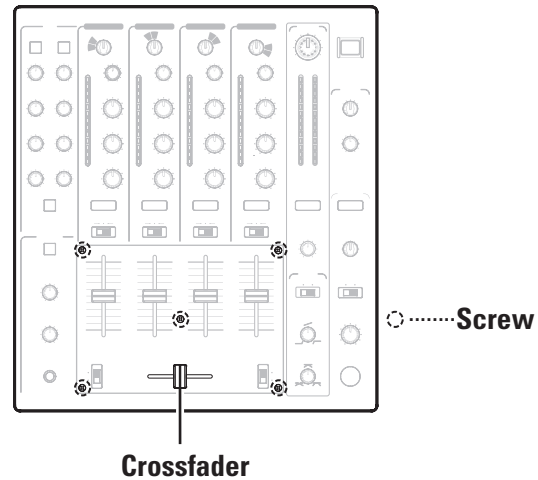

Specifications

General

Maximum external dimensions:	320 (W) x 357 (D) x 91 (H) mm		
Installation:	Table-Top		
Weight:	6.2 kg		
Power supply:	120 V AC (100 – 240 V, 60 Hz)	(U.S.A. and Canada models)	
	230 V AC (100 – 240 V, 50 Hz)	(European models)	
Power consumption:	17 W		
Environmental conditions:	Operational temperature:	5 to 35°C	(41 to 95°F)
	Operational humidity:	25 to 85%	(no condensation)
	Storage temperature:	-20 to 60°C	(4 to 140°F)

Audio section

Input Sensitivity & Impedance:

Main Mic:	-54 dBV (2.0 mV)	10 k Ω /kohms
Aux Mic:	-60 dBV (1.0 mV)	10 k Ω /kohms
Effect (Return):	-14 dBV (200 mV)	50 k Ω /kohms
3-Phono:	-50 dBV (3.0 mV)	50 k Ω /kohms
8-Line:	-14 dBV (200 mV)	50 k Ω /kohms

Output level & Impedance:

Main (Balanced):	4 dBm (1.23 V)	600 Ω /ohms load
Main (Unbalanced):	0 dBm (1.0 V)	1 k Ω /ohms
Booth (Balanced):	4 dBm (1.23 V)	600 Ω /ohms
Rec (RCA):	-10 dBV (316 mV)	1 k Ω /kohms
Effect (Send):	-14 dBV (200 mV)	1 k Ω /kohms
Headphone:	0 dBV (1.0 V)	32 Ω /ohms (33 Ω /ohms load)

Frequency Response:

Line:	20 to 20 kHz \pm 2 dB
Phono:	20 to 20 kHz RIAA \pm 2 dB
Mic:	20 to 20 kHz \pm 2 dB

Signal to Noise ratio:

Line:	82 dB	0 dBm, 1 kHz, EQ flat
Phono:	75 dB	0 dBm, 1 kHz, EQ flat
Main Mic:	65 dB	0 dBm, 1 kHz, EQ flat

Total harmonic distortion rate:

Line:	Below 0.05%
Phono:	Below 0.05%
Cross talk:	Over 70 dB

Channel equalizer:

Hi:	+10 dB, -33 dB (16 kHz)
Mid:	+10 dB, -35 dB (1 kHz)
Low:	+6 dB, -35 dB (60 Hz)

Microphone equalizer:

Hi:	+12 dB, -12 dB (10 kHz)
Mid:	+12 dB, -12 dB (1 kHz)
Low:	+12 dB, -12 dB (100 Hz)

* Specifications and design are subject to change without notice for purpose of improvement.

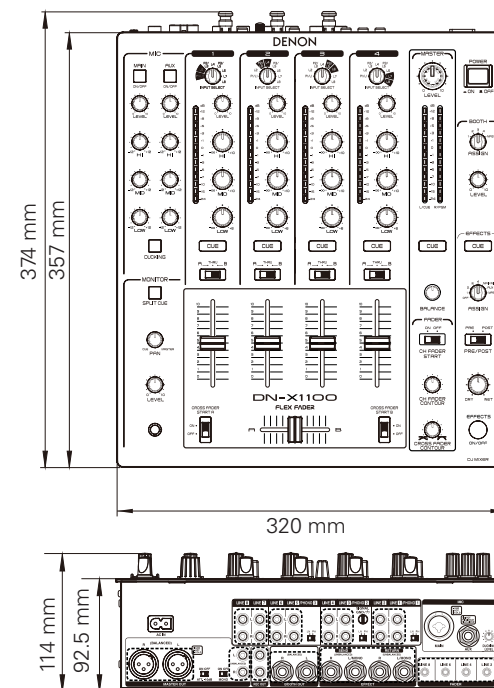

Unit: mm

D&M Holdings Inc.

TOKYO, JAPAN
www.denon.com

Professional Business Company, D&M Holdings Inc.
Printed in China 5411 10309 006P

Free Manuals Download Website

<http://myh66.com>

<http://usermanuals.us>

<http://www.somanuals.com>

<http://www.4manuals.cc>

<http://www.manual-lib.com>

<http://www.404manual.com>

<http://www.luxmanual.com>

<http://aubethermostatmanual.com>

Golf course search by state

<http://golfingnear.com>

Email search by domain

<http://emailbydomain.com>

Auto manuals search

<http://auto.somanuals.com>

TV manuals search

<http://tv.somanuals.com>