

DENON

Professional DIGITAL DJ Mixer

DN-X600

Owner's Manual

IMPORTANT TO SAFETY

WARNING:

To reduce the risk of fire and electric shock, this apparatus should not be exposed to rain or moisture and objects filled with liquids, such as vases, should not be placed on this apparatus

CAUTION

1. Handle the power supply cord carefully

Do not damage or deform the power supply cord. If it is damaged or deformed, it may cause electric shock or malfunction when used. When removing from wall outlet, be sure to remove by holding the plug attachment and not by pulling the cord.

2. Do not open the rear cover

In order to prevent electric shock, do not open the top cover. If problems occur, contact your DENON DEALER.

3. Do not place anything inside

Do not place metal objects or spill liquid inside the system. Electric shock or malfunction may result.

Please, record and retain the Model name and serial number of your set shown on the rating label.

Model No. DN-X600

Serial No. _____



CAUTION
RISK OF ELECTRIC SHOCK
DO NOT OPEN



CAUTION:

TO REDUCE THE RISK OF ELECTRIC SHOCK, DO NOT REMOVE COVER (OR BACK). NO USER-SERVICEABLE PARTS INSIDE. REFER SERVICING TO QUALIFIED SERVICE PERSONNEL.



The lightning flash with arrowhead symbol, within an equilateral triangle, is intended to alert the user to the presence of uninsulated "dangerous voltage" within the product's enclosure that may be of sufficient magnitude to constitute a risk of electric shock to persons.



The exclamation point within an equilateral triangle is intended to alert the user to the presence of important operating and maintenance (servicing) instructions in the literature accompanying the appliance.

CAUTION:

USE OF CONTROLS OR ADJUSTMENTS OR REFORMATION OF PROCEDURES OTHER THAN THOSE SPECIFIED HEREIN MAY RESULT IN HAZARDOUS RADIATION EXPOSURE.

FCC INFORMATION (For US customers)

1. COMPLIANCE INFORMATION

Product Name: DJ MIXER

Model Number: DN-X600

This product complies with Part 15 of the FCC Rules. Operation is subject to the following two conditions: (1) this product may not cause harmful interference, and (2) this product must accept any interference received, including interference that may cause undesired operation.

Denon Professional div. D&M Professional
1100 Maplewood Drive Itasca, IL 60143
Tel. 630-741-0330

2. IMPORTANT NOTICE: DO NOT MODIFY THIS PRODUCT

This product, when installed as indicated in the instructions contained in this manual, meets FCC requirements. Modification not expressly approved by DENON may void your authority, granted by the FCC, to use the product.

3. NOTE

This product has been tested and found to comply with the limits for a Class B digital device, pursuant to Part 15 of the FCC Rules. These limits are designed to provide reasonable protection against harmful interference in a residential installation.

This product generates, uses and can radiate radio frequency energy and, if not installed and used in accordance with the instructions, may cause harmful interference to radio communications. However, there is no guarantee that interference will not occur in a particular installation. If this product does cause harmful interference to radio or television reception, which can be determined by turning the product OFF and ON, the user is encouraged to try to correct the interference by one or more of the following measures:

- Reorient or relocate the receiving antenna.
- Increase the separation between the equipment and receiver.
- Connect the product into an outlet on a circuit different from that to which the receiver is connected.
- Consult the local retailer authorized to distribute this type of product or an experienced radio/TV technician for help.

This Class B apparatus complies with Canadian ICES-003.

Cet appareil numérique de la classe B est conforme à la norme NMB-003 du Canada.

IMPORTANT SAFETY INSTRUCTIONS

READ BEFORE OPERATING EQUIPMENT

This product was designed and manufactured to meet strict quality and safety standards. There are, however, some installation and operation precautions which you should be particularly aware of.

1. Read these instructions.
2. Keep these instructions.
3. Heed all warnings.
4. Follow all instructions.
5. Do not use this apparatus near water.
6. Clean only with dry cloth.
7. Do not block any ventilation openings. Install in accordance with the manufacturer's instructions.
8. Do not install near any heat sources such as radiators, heat registers, stoves, or other apparatus (including amplifiers) that produce heat.
9. Do not defeat the safety purpose of the polarized or grounding-type plug. A polarized plug has two blades with one wider than the other. A grounding type plug has two blades and a third grounding prong. The wide blade or the third prong are provided for your safety. If the provided plug does not fit into your outlet, consult an electrician for replacement of the obsolete outlet.
10. Protect the power cord from being walked on or pinched particularly at plugs, convenience receptacles, and the point where they exit from the apparatus.
11. Only use attachments/accessories specified by the manufacturer.
12. Use only with the cart, stand, tripod, bracket, or table specified by the manufacturer, or sold with the apparatus. When a cart is used, use caution when moving the cart/apparatus combination to avoid injury from tip-over.
13. Unplug this apparatus during lightning storms or when unused for long periods of time.
14. Refer all servicing to qualified service personnel. Servicing is required when the apparatus has been damaged in any way, such as power-supply cord or plug is damaged, liquid has been spilled or objects have fallen into the apparatus, the apparatus has been exposed to rain or moisture, does not operate normally, or has been dropped.
15. Batteries shall not be exposed to excessive heat such as sunshine, fire or the like.



CAUTION: (English)

To completely disconnect this product from the mains, disconnect the plug from the wall socket outlet. The mains plug is used to completely interrupt the power supply to the unit and must be within easy access by the user. Do not expose batteries to excessive heat such as sunshine, fire or the like.

VORSICHT: (Deutsch)

Um dieses Gerät vollständig von der Stromversorgung abzutrennen, trennen Sie bitte den Netzstecker von der Wandsteckdose ab. Die Hauptstecker werden verwendet, um die Stromversorgung zum Gerät völlig zu unterbrechen; er muss für den Benutzer gut und einfach zu erreichen sein. Setzen Sie Batterien nicht übermäßiger Wärme aus, z. B. Sonnenstrahlung, Feuer oder dergleichen.

PRECAUTION: (Français)

Pour déconnecter complètement ce produit du courant secteur, débranchez la prise de la prise murale. La prise secteur est utilisée pour couper complètement l'alimentation de l'appareil et l'utilisateur doit pouvoir y accéder facilement. N'exposez pas les batteries à une chaleur excessive telle que le soleil, le feu ou autre.

ATTENZIONE: (Italiano)

Per scollegare definitivamente questo prodotto dalla rete di alimentazione elettrica, togliere la spina dalla relativa presa. La spina di rete viene utilizzata per interrompere completamente l'alimentazione all'unità e deve essere facilmente accessibile all'utente. Non esporre le batterie a un calore eccessivo, per esempio al sole, al fuoco o altre fonti.

PRECAUCIÓN: (Español)

Para desconectar completamente este producto de la alimentación eléctrica, desconecte el enchufe del enchufe de la pared. El enchufe de la alimentación se utiliza para interrumpir por completo el suministro de alimentación a la unidad y debe de encontrarse en un lugar al que el usuario tenga fácil acceso. No exponga las pilas a calor excesivo, como a la luz solar, el fuego, etc.

VOORZICHTIGHEID: (Nederlands)

Om de voeding van dit product volledig te onderbreken moet de stekker uit het stopcontact worden getrokken. De netstekker wordt gebruikt om de stroomtoevoer naar het toestel volledig te onderbreken en moet voor de gebruiker gemakkelijk bereikbaar zijn. Stel de batterijen niet bloot aan felle zonneschijn, brand, enzovoorts.

FÖRSIKTIHETSMÅTT: (Svenska)

Koppla loss stickproppen från eluttaget för att helt skilja produkten från nätet. Stickproppen används för att helt bryta strömförsörjningen till apparaten, och den måste vara lättillgänglig för användaren. Utsätt inte batterierna för stark hetta såsom solsken, eld eller liknande.

NOTE ON USE / HINWEISE ZUM GEBRAUCH

WARNINGS	WARNHINWEISE
<ul style="list-style-type: none"> • Avoid high temperatures. Allow for sufficient heat dispersion when installed in a rack. • Handle the power cord carefully. Hold the plug when unplugging the cord. • Keep the unit free from moisture, water, and dust. • Unplug the power cord when not using the unit for long periods of time. • Do not obstruct the ventilation holes. • Do not let foreign objects into the unit. • Do not let insecticides, benzene, and thinner come in contact with the unit. • Never disassemble or modify the unit in any way. • Ventilation should not be impeded by covering the ventilation openings with items, such as newspapers, tablecloths or curtains. • Naked flame sources such as lighted candles should not be placed on the unit. • Observe and follow local regulations regarding battery disposal. • Do not expose the unit to dripping or splashing fluids. • Do not place objects filled with liquids, such as vases, on the unit. • Do not handle the mains cord with wet hands. • When the switch is in the OFF position, the equipment is not completely switched off from MAINS. • The equipment shall be installed near the power supply so that the power supply is easily accessible. 	<ul style="list-style-type: none"> • Vermeiden Sie hohe Temperaturen. Beachten Sie, dass eine ausreichende Belüftung gewährleistet wird, wenn das Gerät auf ein Regal gestellt wird. • Gehen Sie vorsichtig mit dem Netzkabel um. Halten Sie das Kabel am Stecker, wenn Sie den Stecker herausziehen. • Halten Sie das Gerät von Feuchtigkeit, Wasser und Staub fern. • Wenn das Gerät längere Zeit nicht verwendet werden soll, trennen Sie das Netzkabel vom Netzstecker. • Decken Sie den Lüftungsbereich nicht ab. • Lassen Sie keine fremden Gegenstände in das Gerät kommen. • Lassen Sie das Gerät nicht mit Insektiziden, Benzin oder Verdünnungsmitteln in Berührung kommen. • Versuchen Sie niemals das Gerät auseinander zu nehmen oder zu verändern. • Die Belüftung sollte auf keinen Fall durch das Abdecken der Belüftungsöffnungen durch Gegenstände wie beispielsweise Zeitungen, Tischtücher, Vorhänge o. Ä. behindert werden. • Auf dem Gerät sollten keinerlei direkte Feuerquellen wie beispielsweise angezündete Kerzen aufgestellt werden. • Bitte beachten Sie bei der Entsorgung der Batterien die örtlich geltenden Umweltbestimmungen. • Das Gerät sollte keiner tropfenden oder spritzenden Flüssigkeit ausgesetzt werden. • Auf dem Gerät sollten keine mit Flüssigkeit gefüllten Behälter wie beispielsweise Vasen aufgestellt werden. • Das Netzkabel nicht mit feuchten oder nassen Händen anfassen. • Wenn der Schalter ausgeschaltet ist (OFF-Position), ist das Gerät nicht vollständig vom Stromnetz (MAINS) abgetrennt. • Das Gerät sollte in der Nähe einer Netzsteckdose aufgestellt werden, damit es leicht an das Stromnetz angeschlossen werden kann.

☐ OBSERVATIONS RELATIVES A L'UTILISATION / NOTE SULL'USO / NOTAS SOBRE EL USO / ALVORENS TE GEBRUIKEN / OBSERVERA

AVERTISSEMENTS	AVVERTENZE	ADVERTENCIAS	WAARSCHUWINGEN	VARNINGAR
<ul style="list-style-type: none"> • Eviter des températures élevées. Tenir compte d'une dispersion de chaleur suffisante lors de l'installation sur une étagère. • Manipuler le cordon d'alimentation avec précaution. Tenir la prise lors du débranchement du cordon. • Protéger l'appareil contre l'humidité, l'eau et la poussière. • Débrancher le cordon d'alimentation lorsque l'appareil n'est pas utilisé pendant de longues périodes. • Ne pas obstruer les trous d'aération. • Ne pas laisser des objets étrangers dans l'appareil. • Ne pas mettre en contact des insecticides, du benzène et un diluant avec l'appareil. • Ne jamais démonter ou modifier l'appareil d'une manière ou d'une autre. • Ne pas recouvrir les orifices de ventilation avec des objets tels que des journaux, nappes ou rideaux. Cela entraverait la ventilation. • Ne jamais placer de flamme nue sur l'appareil, notamment des bougies allumées. • Veillez à respecter les lois en vigueur lorsque vous jetez les piles usagées. • L'appareil ne doit pas être exposé à l'eau ou à l'humidité. • Ne pas poser d'objet contenant du liquide, par exemple un vase, sur l'appareil. • Ne pas manipuler le cordon d'alimentation avec les mains mouillées. • Lorsque l'interrupteur est sur la position OFF, l'appareil n'est pas complètement déconnecté du SECTEUR (MAINS). • L'appareil sera installé près de la source d'alimentation, de sorte que cette dernière soit facilement accessible. 	<ul style="list-style-type: none"> • Evitate di esporre l'unità a temperature elevate. Assicuratevi che vi sia un'adeguata dispersione del calore quando installate l'unità in un mobile per componenti audio. • Maneggiare il cavo di alimentazione con attenzione. Tenete ferma la spina quando scollegate il cavo dalla presa. • Tenete l'unità lontana dall'umidità, dall'acqua e dalla polvere. • Scollegate il cavo di alimentazione quando prevedete di non utilizzare l'unità per un lungo periodo di tempo. • Non coprite i fori di ventilazione. • Non inserite corpi estranei all'interno dell'unità. • Assicuratevi che l'unità non entri in contatto con insetticidi, benzolo o solventi. • Non smontate né modificate l'unità in alcun modo. • Le aperture di ventilazione non devono essere ostruite coprendole con oggetti, quali giornali, tovaglie, tende e così via. • Non posizionate sull'unità fi amme libere, come ad esempio candele accese. • Prestate attenzione agli aspetti legati alla tutela dell'ambiente nello smaltimento delle batterie. • L'apparecchiatura non deve essere esposta a gocciolii o spruzzi. • Non posizionate sull'unità alcun oggetto contenente liquidi, come ad esempio i vasi. • Non toccare il cavo di alimentazione con le mani bagnate. • Quando l'interruttore è nella posizione OFF, l'apparecchiatura non è completamente scollegata da MAINS. • L'apparecchio va installato in prossimità della fonte di alimentazione, in modo che quest'ultima sia facilmente accessibile. 	<ul style="list-style-type: none"> • Evite altas temperaturas. Permite la suficiente dispersión del calor cuando está instalado en la consola. • Maneje el cordón de energía con cuidado. Sostenga el enchufe cuando desconecte el cordón de energía. • Mantenga el equipo libre de humedad, agua y polvo. • Desconecte el cordón de energía cuando no utilice el equipo por mucho tiempo. • No obstruya los orificios de ventilación. • No deje objetos extraños dentro del equipo. • No permita el contacto de insecticidas, gasolina y diluyentes con el equipo. • Nunca desarme o modifique el equipo de ninguna manera. • La ventilación no debe quedar obstruida por haberse cubierto las aperturas con objetos como periódicos, manteles o cortinas. • No deberán colocarse sobre el aparato fuentes inflamables sin protección, como velas encendidas. • A la hora de deshacerse de las pilas, respete la normativa para el cuidado del medio ambiente. • No exponer el aparato al goteo o salpicaduras cuando se utilice. • No colocar sobre el aparato objetos llenos de líquido, como jarros. • No maneje el cable de alimentación con las manos mojadas. • Cuando el interruptor está en la posición OFF, el equipo no está completamente desconectado de la alimentación MAINS. • El equipo se instalará cerca de la fuente de alimentación de manera que resulte fácil acceder a ella. 	<ul style="list-style-type: none"> • Vermijd hoge temperaturen. Zorg er bij installatie in een audiorack voor, dat de door het toestel geproduceerde warmte goed kan worden afgevoerd. • Hanteer het netsnoer voorzichtig. Houd het snoer bij de stekker vast wanneer deze moet worden aan- of losgekoppeld. • Laat geen vochtigheid, water of stof in het apparaat binnendringen. • Neem altijd het netsnoer uit het stopcontact wanneer het apparaat gedurende een lange periode niet wordt gebruikt. • De ventilatieopeningen mogen niet worden geblokkeerd. • Laat geen vreemde voorwerpen in dit apparaat vallen. • Voorkom dat insecticiden, benzeen of verfverdunder met dit toestel in contact komen. • Dit toestel mag niet gedemonteerd of aangepast worden. • De ventilatie mag niet worden belemmerd door de ventilatieopeningen af te dekken met bijvoorbeeld kranten, een tafelkleed of gordijnen. • Plaats geen open vlammen, bijvoorbeeld een brandende kaars, op het apparaat. • Houd u steeds aan de milieuvoorschriften wanneer u gebruikte batterijen wegdoet. • Stel het apparaat niet bloot aan druppels of spatten. • Plaats geen voorwerpen gevuld met water, bijvoorbeeld een vaas, op het apparaat. • Raak het netsnoer niet met natte handen aan. • Als de schakelaar op OFF staat, is het apparaat niet volledig losgekoppeld van de netspanning (MAINS). • De apparatuur wordt in de buurt van het stopcontact geïnstalleerd, zodat dit altijd gemakkelijk toegankelijk is. 	<ul style="list-style-type: none"> • Undvik höga temperaturer. Se till att det finns möjlighet till god värmeavledning vid montering i ett rack. • Hantera nätkabeln varsamt. Håll i kabeln när den kopplas från el-uttaget. • Utsätt inte apparaten för fukt, vatten och damm. • Koppla loss nätkabeln om apparaten inte kommer att användas i lång tid. • Tapp inte till ventilationsöppningarna. • Se till att främmande föremål inte tränger in i apparaten. • Se till att inte insektsmedel på spraybruk, bensen och thinner kommer i kontakt med apparatens hölje. • Ta inte isär apparaten och försök inte bygga om den. • Ventilationen bör inte förhindras genom att täcka för ventilationsöppningarna med föremål såsom tidningar, bordsdukar eller gardiner. • Placera inte öppen eld, t.ex. tända ljus, på apparaten. • Tänk på miljöaspekterna när du bortskaffar batterier. • Apparaten får inte utsättas för vätska. • Placera inte föremål fyllda med vätska, t.ex. vaser, på apparaten. • Hantera inte nätsladden med våta händer. • Även om strömbrytaren står i det avstängda läget OFF, så är utrustningen inte helt bortkopplad från det elektriska nätet (MAINS). • Utrustningen ska vara installerad nära strömmuttaget så att strömförsörjningen är lätt att tillgå.

CAUTION

- The ventilation should not be impeded by covering the ventilation openings with items, such as newspapers, tablecloths, curtains, etc.
- No naked flame sources, such as lighted candles, should be placed on the apparatus.
- Attention should be drawn to the environmental aspects of battery disposal.
- The apparatus shall not be exposed to dripping or splashing for use.
- No objects filled with liquids, such as vases, shall be placed on the apparatus.

•DECLARATION OF CONFORMITY**(English)**

We declare under our sole responsibility that this product, to which this declaration relates, is in conformity with the following standards:

EN60065, EN55013, EN55020, EN61000-3-2 and EN61000-3-3.

Following the provisions of Low Voltage Directive 2006/95/EC and EMC Directive 2004/108/EC, the EC regulation 1275/2008 and its frame work Directive 2009/125/EC for Energy-related Products (ErP).

•ÜBEREINSTIMMUNGSERKLÄRUNG**(Deutsch)**

Wir erklären unter unserer Verantwortung, daß dieses Produkt, auf das sich diese Erklärung bezieht, den folgenden Standards entspricht:

EN60065, EN55013, EN55020, EN61000-3-2 und EN61000-3-3.

Gemäß den Bestimmungen der Niederspannungsrichtlinie 2006/95/EG und EMV Richtlinie 2004/108/EG, der Verordnung (EG) Nr. 1275/2008 der Kommission und deren Rahmenrichtlinie 2009/125/EG zu energieverbrauchsrelevanten Produkten (ErP).

•DECLARATION DE CONFORMITE**(Français)**

Nous déclarons sous notre seule responsabilité que l'appareil, auquel se réfère cette déclaration, est conforme aux standards suivants:

EN60065, EN55013, EN55020, EN61000-3-2 et EN61000-3-3.

Selon la directive 2006/95/EC concernant la basse tension et la directive CEM 2004/108/EC, la réglementation européenne 1275/2008 et la directive 2009/125/EC établissant un cadre de travail applicable aux produits liés à l'énergie (ErP).

•DICHIAZIONE DI CONFORMITÀ**(Italiano)**

Dichiariamo con piena responsabilità che questo prodotto, al quale la nostra dichiarazione si riferisce, è conforme alle seguenti normative:

EN60065, EN55013, EN55020, EN61000-3-2 e EN61000-3-3.

Facendo seguito alle disposizioni della direttiva sul basso voltaggio 2006/95/EC alla direttiva EMC 2004/108/EC, alla norma EC 1275/2008 e alla relativa legge quadro 2009/125/EC in materia di prodotti alimentati ad energia (ErP).

QUESTO PRODOTTO E' CONFORME

AL D.M. 28/08/95 N. 548

•DECLARACIÓN DE CONFORMIDAD**(Español)**

Declaramos bajo nuestra exclusiva responsabilidad que este producto al que hace referencia esta declaración, está conforme con los siguientes estándares:

EN60065, EN55013, EN55020, EN61000-3-2 y EN61000-3-3.

De acuerdo con la directiva sobre baja tensión 2006/95/CE y la directiva sobre CEM 2004/108/CE, la normativa CE 1275/2008 y su directiva marco 2009/125/EC para productos relacionados con la energía (ErP).

•EENVORMIGHEIDSVERKLARING**(Nederlands)**

Wij verklaren uitsluitend op onze verantwoordelijkheid dat dit produkt, waarop deze verklaring betrekking heeft, in overeenstemming is met de volgende normen:

EN60065, EN55013, EN55020, EN61000-3-2 en EN61000-3-3.

Volgens de voorzieningen van lage spanningsrichtlijn 2006/95/EC en EMC-richtlijn 2004/108/EC, de EU-richtlijn 1275/2008 en de kaderrichtlijn 2009/125/EC voor energieverbruikende producten (ErP).

•ÖVERENSSTÄMMELSESTYTG**(Svenska)**

Härmed intygas helt på eget ansvar att denna produkt, vilken detta intyg avser, uppfyller följande standarder:

EN60065, EN55013, EN55020, EN61000-3-2 och EN61000-3-3.

Uppfyller reglerna i lågspänningsdirektivet 2006/95/EC och EMC-direktivet 2004/108/EC, EU-förordningen 1275/2008 och ramverksdirektivet 2009/125/EC för energirelaterade produkter (ErP).

D&M Professional Europe
Kingsbridge House
Padbury Oaks
Longford
Middlesex
UB7 0EH
UK

A NOTE ABOUT RECYCLING:

This product's packaging materials are recyclable and can be reused. Please dispose of any materials in accordance with the local recycling regulations.
When discarding the unit, comply with local rules or regulations.
Batteries should never be thrown away or incinerated but disposed of in accordance with the local regulations concerning battery disposal.
This product and the supplied accessories, excluding the batteries, constitute the applicable product according to the WEEE directive.

HINWEIS ZUM RECYCLING:

Das Verpackungsmaterial dieses Produktes ist zum Recyceln geeignet und kann wieder verwendet werden. Bitte entsorgen Sie alle Materialien entsprechend der örtlichen Recycling-Vorschriften.
Beachten Sie bei der Entsorgung des Gerätes die örtlichen Vorschriften und Bestimmungen.
Die Batterien dürfen nicht in den Hausmüll geworfen oder verbrannt werden; bitte entsorgen Sie die Batterien gemäß der örtlichen Vorschriften.
Dieses Produkt und das im Lieferumfang enthaltene Zubehör (mit Ausnahme der Batterien!) entsprechen der WEEE-Direktive.

UNE REMARQUE CONCERNANT LE RECYCLAGE:

Les matériaux d'emballage de ce produit sont recyclables et peuvent être réutilisés. Veuillez disposer des matériaux conformément aux lois sur le recyclage en vigueur.
Lorsque vous mettez cet appareil au rebut, respectez les lois ou réglementations en vigueur.
Les piles ne doivent jamais être jetées ou incinérées, mais mises au rebut conformément aux lois en vigueur sur la mise au rebut des piles.
Ce produit et les accessoires inclus, à l'exception des piles, sont des produits conformes à la directive DEEE.

NOTA RELATIVA AL RICICLAGGIO:

I materiali di imballaggio di questo prodotto sono riutilizzabili e riciclabili. Smaltire i materiali conformemente alle normative locali sul riciclaggio.
Per lo smaltimento dell'unità, osservare le normative o le leggi locali in vigore.
Non gettare le batterie, né incenerirle, ma smaltirle conformemente alla normativa locale sui rifiuti chimici.
Questo prodotto e gli accessori inclusi nell'imballaggio sono applicabili alla direttiva RAEE, ad eccezione delle batterie.

ACERCA DEL RECICLAJE:

Los materiales de embalaje de este producto son reciclables y se pueden volver a utilizar. Disponga de estos materiales siguiendo los reglamentos de reciclaje de su localidad.
Cuando se deshaga de la unidad, cumpla con las reglas o reglamentos locales.
Las pilas nunca deberán tirarse ni incinerarse. Deberá disponer de ellas siguiendo los reglamentos de su localidad relacionados con los desperdicios químicos.
Este producto junto con los accesorios empaquetados es el producto aplicable a la directiva RAEE excepto pilas.

EEN AANTEKENING MET BETREKKING TOT DE RECYCLING:

Het inpakmateriaal van dit product is recycleerbaar en kan opnieuw gebruikt worden. Er wordt verzocht om zich van elk afvalmateriaal te ontdoen volgens de plaatselijke voorschriften.
Volg voor het wegdoen van de speler de voorschriften voor de verwijdering van wit- en bruingoed op.
Batterijen mogen nooit worden weggegooid of verbrand, maar moeten volgens de plaatselijke voorschriften betreffende chemisch afval worden verwijderd.
Op dit product en de meegeleverde accessoires, m.u.v. de batterijen is de richtlijn voor afgedankte elektrische en elektronische apparaten (WEEE) van toepassing.

OBSERVERA ANGÅENDE ÅTERVINNING:

Produktens emballage är återvinningsbart och kan återanvändas. Kassera det enligt lokala återvinningsbestämmelser.
När du kasserar enheten ska du göra det i överensstämmelse med lokala regler och bestämmelser.
Batterier får absolut inte kastas i soporna eller brännas. Kassera dem enligt lokala bestämmelser för kemiskt avfall.
Denna apparat och de tillbehör som levereras med den uppfyller gällande WEEE-direktiv, med undantag av batterierna.



Pb

CAUTIONS ON INSTALLATION
VORSICHTSHINWEISE ZUR AUFSTELLUNG
PRÉCAUTIONS D'INSTALLATION
PRECAUZIONI SULL'INSTALLAZIONE
EMPLAZAMIENTO DE LA INSTALACIÓN
VOORZORGSMATREGELEN BIJ DE INSTALLATIE
FÖRSIKTIGHET VID INSTALLATIONEN

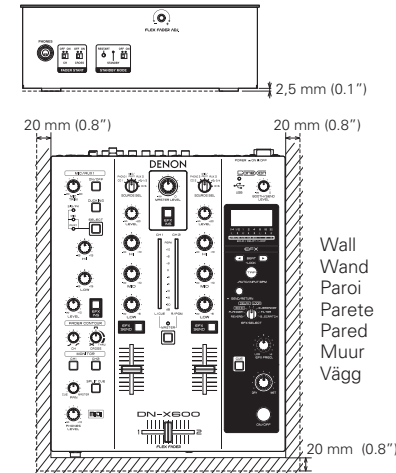

- * For proper heat dispersal, do not install this unit in a confined space, such as a bookcase or similar enclosure.
- * Stellen Sie das Gerät nicht an einem geschlossenen Ort, wie in einem Bücherregal oder einer ähnlichen Einrichtung auf, da dies eine ausreichende Belüftung des Geräts behindern könnte.
- * Pour permettre la dissipation de chaleur requise, n'installez pas cette unité dans un espace confiné tel qu'une bibliothèque ou un endroit similaire.
- * Per una dispersione adeguata del calore, non installare questa apparecchiatura in uno spazio ristretto, come ad esempio una libreria o simili.
- * Para la dispersión del calor adecuadamente, no instale este equipo en un lugar confinado tal como una librería o unidad similar.
- * Plaats dit toestel niet in een kleine afgesloten ruimte, zoals een boekenkast e.d., omdat anders de warmte niet op gepaste wijze kan worden afgevoerd.
- * För att tillförsäkra god värmeavledning får utrustningen inte installeras i instängda utrymmen, som t.ex. en bokhylla eller liknande.

Before use

Contents

Before use	1
Accessories	1
About this manual	1
Main features	2
Cautions on handling	2
Part names and functions	3
Top panel	3
Front panel	4
Rear panel	5
Connections	6
Preparations	6
Cables used for connection	6
Input terminal connection	6
Input from external devices	6
Mic connection	7
Output terminal connections	7
Output to the amplifier	7
Connection of the booth output terminal	7
Input/Output terminal connections	8
Connection to a computer	8
Connection to an external effects processor	8
Connecting the power cord	8
Basic operation	9
Basic operation	9
MIC (Mic input)	9
Headphone monitor	9
Effector function	10
Type of Effect and operation detail.	10
Send/Return function	10
Required settings and connections	10
Selecting the send/return function	10
BeatBreaker function	10
Details of operation	10
How to operate	10
Operating the effector	11
Beat setting	11
Fader start function	12
Channel fader start	12
Cross fader start	12
Fader curve adjustment	13
Adjusting the cross fader torque	13
USB settings	13
Computer OS settings	13
USB device mode	14
USB audio input/output	14
Selecting the sampling frequency	14
USB audio output	14
USB audio input mode settings	14
MIDI command output	15
MIDI output channel settings	15
MIDI clock synchronization	15
Playback using the DVS function	15
Connections	15
DVS playback	15
Troubleshooting	17
Specifications	18
Index	19
System diagram	20

Accessories

Check that the following parts are supplied with the product.

NOTE

Conduction noise or interference noise may cause the DN-X600 to malfunction. Therefore, when connecting this device to a computer, connect using the USB cable included.

① Owner's manual	1
② CD-ROM	1
③ USB cable	1
④ Warranty (for North America model only)	1

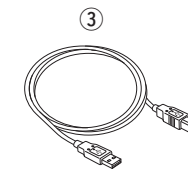

About this manual

□ Symbols



This symbol indicates a reference page on which related information is described.



This symbol indicates a supplementary information and tips for operations.

NOTE

This symbol indicates points to remember operations or function limitations.

□ Illustrations

Note that the illustrations in these instructions are for explanation purposes and may differ from the actual unit.

Main features

1. Wide range of input and output terminals

The input and output terminals available on this unit are described below.

Input

- CD 2
- PHONO 2
- Mic 1
- AUX1 1
- AUX2 1 /Effect 1 (combined use)

Output

- Master 2
- Booth 1 /Effect 1 (combined use)

Input/Output

- USB Audio Interface

Additionally, this unit is a 96kHz/32 bit DAC supported DJ full digital mixer equipped with USB MIDI and terminal output MIDI interface.

2. Designed to achieve high sound quality

- The unit features a 96 kHz/32-bit floating digital signal processor (DSP) and 32-bit digital-to-analog converter (DAC) (master output). The unit delivers high quality sound that is faithful to the original sound source.
- An electrolytic capacitor designed to enhance sound quality is employed in the power supply unit. Additionally, film capacitors that are designed to enhance sound quality and high-precision metal film resistors are used to configure the audio signal processing unit, resulting in superb quality sound.
- The unit is equipped with a microphone amplifier that features a discrete transistor configuration and low equivalent input noise of 126 dB, and a PHONO amplifier that features a signal to noise ratio of 89 dB.

3. Multiple Effects

Specific parameters for each of the 8 different effects can be linked to the beats per minute (BPM) of every track passing through the mixer. The effects processor offers its own set of controls such as, Dry/Wet mix, Parameter Low/High pass filter, Cross Over filter, Beat time adjustments, TAP, Manual and Auto BPM, Pre Efx Cueing and ON/OFF.

4. USB audio and MIDI interfaces

- 8-channel (4 stereo channels) 96 kHz USB audio input/output function
- DVS (Digital Vinyl System) compatible.
- Most of the panel operations can output MIDI.
- The MIDI clock signal is detected from the computer, and can be automatically used as a BPM value.
- The unit incorporates an effect send/return function that allows effects to be applied to audio output from this unit using effector software on a computer, and then to re-input the audio into the unit.
- A low latency ASIO driver is also included with the unit.

5. High-reliability design for professional use

- Isolator filters are incorporated for each input channel.
- Crossfader slide torque can be adjusted to personal preferences.
- Matrix source selectors enable the selection of any of 6 input sources

6. Others

- Ducking function reduces the amount of background sound during mic usage.
- Channel Fader and Crossfader start function
- Auto Standby function (Eco mode)

Cautions on handling

• Before turning the power switch on

Check once again that all connections are correct and that there are no problems with the connection cables.

- Power is supplied to some of the circuitry even when the unit is set to the standby mode. When going on vacation or leaving home for long periods of time, be sure to unplug the power cord from the power outlet.

• About Condensation

If there is a major difference in temperature between the inside of the unit and the surroundings, condensation (dew) may form on the operating parts inside the unit, causing the unit not to operate properly.

If this happens, let the unit sit for an hour or two with the power turned off and wait until there is little difference in temperature before using the unit.

• Cautions on using mobile phones

Using a mobile phone near this unit may result in noise. If that occurs, move the mobile phone away from this unit when it is in use.

• Moving the unit

Turn off the power and unplug the power cord from the power outlet. Next, disconnect the connection cables to other system units before moving the unit.

• About Care

- Wipe the cabinet and control panel clean with a soft cloth.
- Follow the instructions when using a chemical cleaner.
- Benzene, paint thinner or other organic solvents as well as insecticide may cause material changes and discoloration if brought into contact with the unit, and should therefore not be used.

Part names and functions

Top panel

For buttons not explained here, see the page indicated in parentheses ().

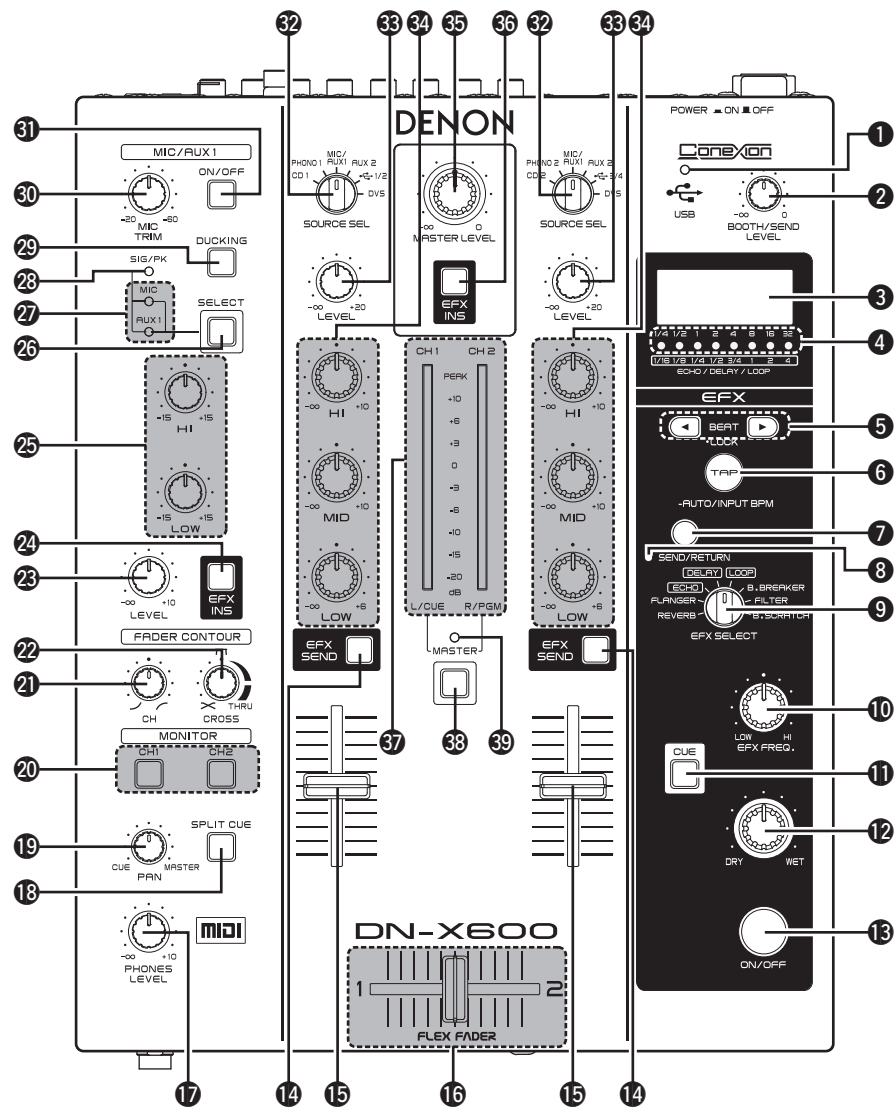

- 1 USB enable display (USB)**
 - Lights a pale blue color when connected to a computer.
 - Lights a deep blue color when MIDI command is sent.
- 2 Booth/Send, Effect/Send level adjustment knob (BOOTH/SEND LEVEL)** (5)
- 3 Display**
Displays the BPM value and device settings.
- 4 Beat display** (11)
- 5 Beat switch button (BEAT)** (11, 14, 15)
- 6 Tap button (TAP/LOCK/AUTO/INPUT BPM)** (11, 14, 15)
TAP:
 - When this button is tapped repeatedly, the BPM is measured using the intervals between taps.**LOCK:**
 - When this button is pressed once in the auto BPM mode, the BPM value measured automatically is locked.**AUTO BPM:**
 - When this button is held down for one second, the mode switches to auto BPM mode, and the measured BPM value is displayed.**INPUT BPM:**
 - When this button is held down for more than 2 seconds, the mode switches to BPM input mode, and the BPM value can be entered directly using the **5** beat selection button. This mode is cleared by pressing the button again.
- 7 Send/Return mode selection button (SEND/RETURN)** (10)
- 8 Send/Return mode display (SEND/RETURN)** (10)
- 9 Effect selection knob (EFX SELECT)** (11)
- 10 Effect filter adjustment knob (EFX FREQ)** (11)
- 11 Effect CUE button (CUE)** (11)
- 12 Dry/Wet adjustment knob (DRY/WET)** (11)
- 13 Effect ON/OFF button (ON/OFF)** (11)
- 14 Channel effect send button (EFX SEND)** (11)
 - Flashes for target AUTO BPM
- 15 Channel fader (CH FADER)** (9, 12)
- 16 Cross fader (CROSS FADER)** (9, 12)
- 17 Headphone level adjustment knob (PHONES LEVEL)** (9)
 - When using headphones, be cautious to avoid prolonged loud volume in order to protect your ears.
- 18 Split cue button (SPLIT CUE)** (9)
- 19 Headphone pan adjustment knob (PAN)** (9)
- 20 Channel monitor selection button (MONITOR CH1/CH2)** (9)
- 21 Channel fader contour adjustment knob (CH FADER CONTOUR)** (13)
- 22 Cross fader contour adjustment knob (CROSS FADER CONTOUR)** (13)
- 23 MIC/AUX1 send level adjustment knob (LEVEL)** (9)
 - Adjusts the send level to the master output for the mic signal or AUX1 input signal.
- 24 MIC/AUX1 effect insertion button (EFX INS)** (9)
 - Various effects can be applied to mic input signals and AUX1 input signals. Flashes for target AUTO BPM
- 25 MIC/AUX1 EQ adjustment knob (HI/LOW)** (9)
 - Adjusts the frequency characteristics for the mic input signal and AUX1 input signal.

- 26 MIC/AUX1 input selection button (SELECT)** (9)
- 27 MIC/AUX1 input display (MIC/AUX1)** (9)
- 28 SIG/PK display** (9)
Signal/peak meter for MIC/AUX1 input level.
Off:
- No signal input. (Less than -60dBFS)
- Green:**
- Signal Input (More than -60dBFS – less than -20dBFS)
- Orange:**
- Suitable Input Level (More than -20dBFS – less than -6dBFS)
- Red:**
- Excessively high signal input level (more than -6dBFS)
- 29 DUCKING ON/OFF button (DUCKING)** (9)
- 30 Mic trim adjustment knob (MIC TRIM)** (9)
Adjusts the input level for the mic input signal and AUX1 input signal.
- 31 Mic ON/OFF button (MIC)** (9)
- 32 Channel input source selection knob (SOURCE SEL)** (9, 12, 15)
- 33 Channel input level adjustment knob (LEVEL)** (9)
- 34 Channel isolator EQ adjustment knob (HI, MID, LOW)** (9)
- 35 Master output level adjustment knob (MASTER LEVEL)** (9)
- 36 Master effect insertion button (EFX INS)** (11, 14)
When this button is pressed, various effects are applied to the master output signal. Flashes for target AUTO BPM
- 37 Channel cue master level meter (CH1, CH2, L/CUE, R/PGM)**
The display can be switched between 2 display modes.
Split CUE OFF:
- Displays the master output volume level.
- Split CUE ON:**
- Displays the volume level for the right channel master CUE (monaural) and left channel CUE (monaural).
- 38 Channel cue master level meter display switch** (14)
- 39 Master level mode display (MASTER)**
• Lights red for the master output mode.
• Off for the channel input mode.

Front panel

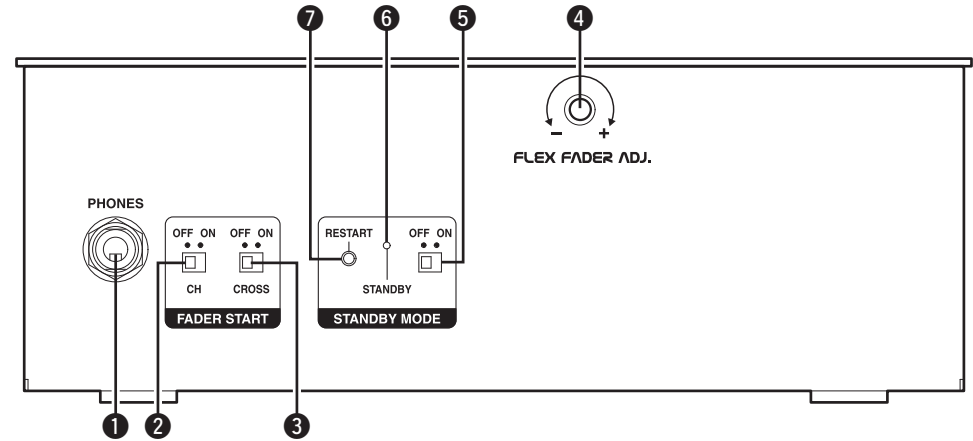

- 1 Headphone jack (PHONES)**
- 2 Channel fader start switch (CH FADER START)** (12)
- 3 Cross fader start switch (CROSS FADER START)** (12)
- 4 Cross fader torque adjustment hole (FLEX FADAR ADJ.)** (13)
- 5 Standby mode switch (STANDBY MODE)** (4)
• **ON:**
Enables the automatic standby function.
• **OFF:**
Disables the automatic standby function.
- 6 Standby display (STANDBY)** (4)
Lights red when in standby mode.
- 7 Restart button (RESTART)** (4)
While this button is pressed when the unit is in standby mode from the automatic standby function, standby mode is cancelled, and the power switches on.

□ About the automatic standby function

While the power is on, if the unit is not operated (*) for approximately 8 hours, or if there is no input from the current input source for approximately 8 hours, the unit automatically enters standby mode.
* :Excluding the mic trim adjustment knob.

Rear panel

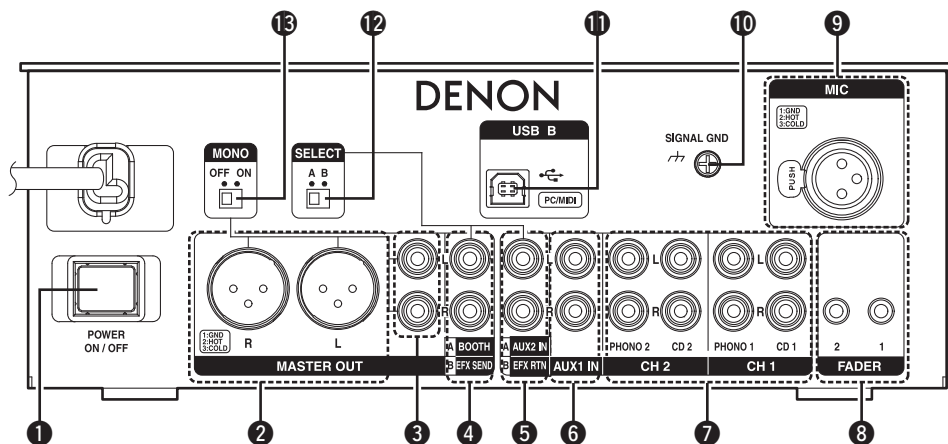

1 Power switch (POWER) (9)

2 Master output (balanced) terminal (MASTER OUT) (7)

Pin layout:

1. Ground (GND)
2. Hot (HOT)
3. Cold (COLD)

Suitable connector:

Cannon XLR-3-31 or equivalent.

3 Master output (unbalanced) terminal (MASTER OUT) (7)

4 Booth/Effect send output terminal (BOOTH/EFX SEND) (7, 8)

SEND (Output) :

- Connect to the input terminal of an external effect processor.

BOOTH (Output) :

- Connect to the input terminal of an active speaker.

5 AUX2/Effect return input terminal (AUX2 IN/EFX RTN) (6, 8)

RETURN (Input):

- Connect to the output terminal of an external effect processor.

AUX2 (Input):

- Connect to the output terminal of an external device.

6 Audio input terminal (AUX1 IN) (6)

7 Audio input terminal (CH1, CH2) (6)
Connect a device such as an MM (Moving Magnet) cartridge turntable (RIAA) or CD player.

8 Fader output terminal (FADER1, 2) (6, 12)

Connect these terminals to the Fader input terminals of the DN-S1200 or DN-S3700 etc using a 3.5 mm stereo mini plug.

9 MIC input terminal (MIC)
Connect a microphone to this balanced combo jack using an XLR connector.

Pin layout:

1. Ground (GND)
2. Hot (HOT)
3. Cold (COLD)

Suitable connector:

Cannon XLR-3-32 or equivalent.

10 Signal earth terminal (SIGNAL GND) (6)

11 USB B terminal (USB B) (8, 15)

12 Input/Output mode selection switch (SELECT A, B) (7, 8)
Selects between the **4** and **5** terminal functions.

NOTE

The input and output volume levels are different for the input mode (SELECT) settings (A or B). Set the correct level to match the connected device.

13 Monaural output selection switch (MONO) (7)
When "ON", mixed monaural audio is outputted from the L and R terminals for XLR and RCA Master outputs.

Connections

NOTE

- Do not plug in the power cord until all connections have been completed.
- When making connections, also refer to the operating instructions of the other components.
- Insert the plugs securely. Loose connections will result in the generation of noise.
- Be sure to connect the left and right channels properly (left with left, right with right).
- Connect the cables to the correct input and output terminals.
- Do not bundle power cords together with connection cables. Doing so can result in humming or noise.

Preparations

Cables used for connection

Select the cables according to the equipment being connected.

For RCA input terminals

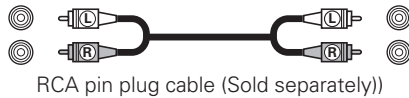

For XLR input/output terminals



For FADER terminals



For USB terminal

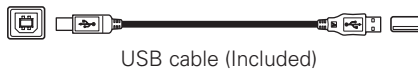

Input terminal connection

Input from external devices

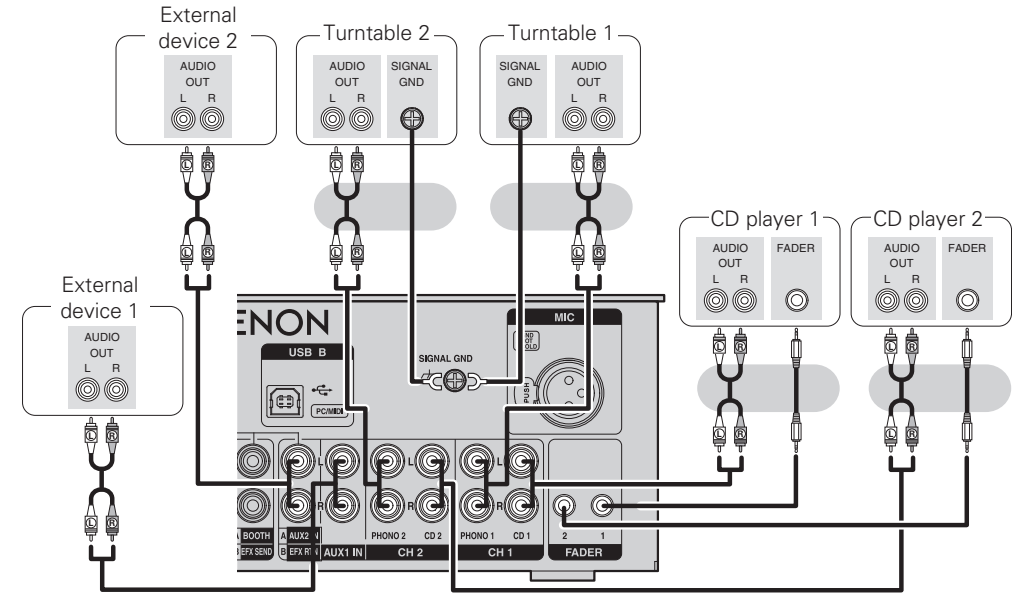

NOTE

- To use the AUX2/Effect/Return input terminal as the AUX2 input terminal, set the SELECT switch to "A".
- To connect a DJ CD player to this unit and use the fader start function, connect this unit to the FADER terminal of the CD player.

Mic connection

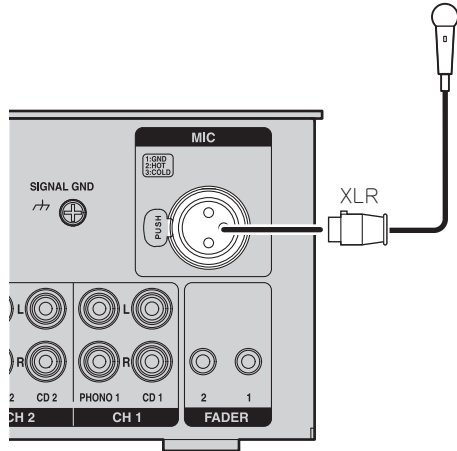

Connect a microphone to this balanced jack using an XLR connector.

Pin layout:

1. Ground (GND)
2. Hot (HOT)
3. Cold (COLD)

Suitable connector:

Cannon XLR-3-32 or equivalent.

Output terminal connections

Output to the amplifier

To switch to monaural audio output



Set the monaural selection switch to "ON".

- When this is "OFF", audio is output in stereo.

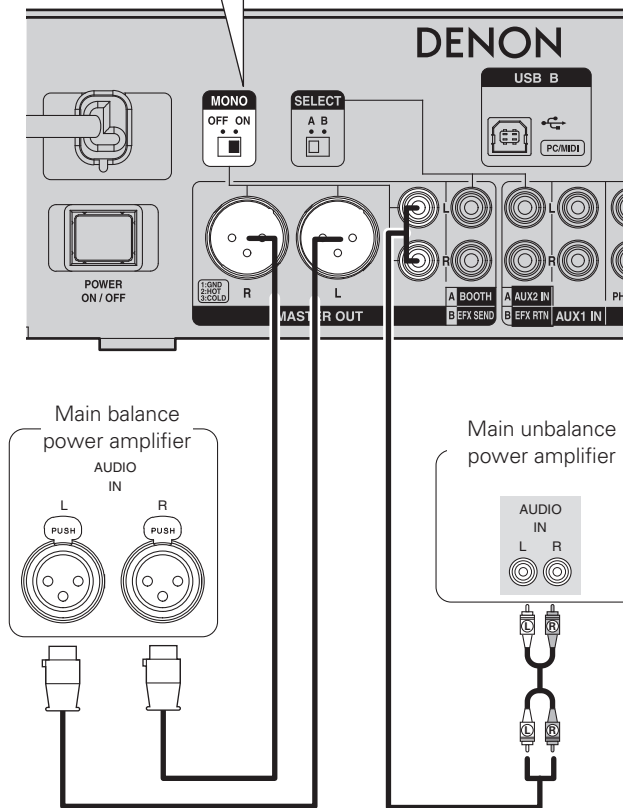

Connection of the booth output terminal



If active speakers or other audio monitors are connected to the booth output terminal, set the SELECT switch to "A".

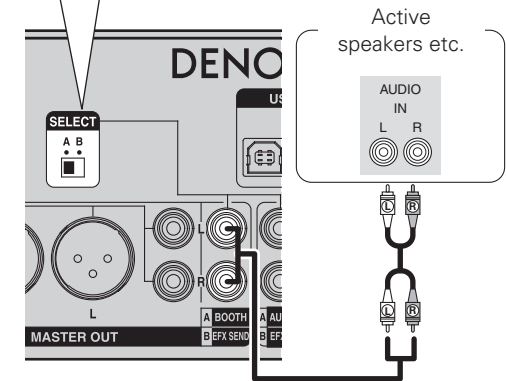

Input/Output terminal connections

Connection to a computer

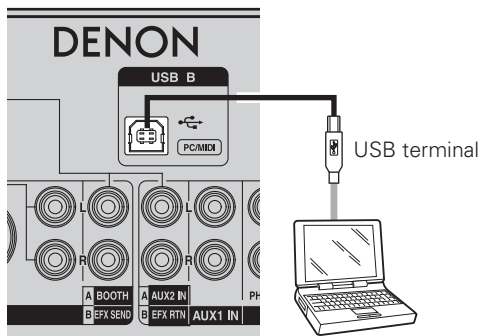

Before connecting a computer to this unit, perform the settings as shown in "Computer OS settings" (page 13).

Compatible computers

- Computers running the following computer OS versions can be connected to this unit.
 - Windows XP SP3 or later (32 Bit only)
 - Windows Vista SP2 or later (32 or 64 Bit)
 - Windows 7 (32 or 64 Bit)
 - Mac OSX 10.6.4 or later
- Computers running other OS versions may not be compatible with the USB MIDI. For this reason, such computers may function abnormally after connecting by USB to this unit.
- This unit operates correctly with Mac OS 10.6.4. Using with Mac OS 10.6.3 or earlier versions may result in unstable sound output from this unit. Also, this unit operates using a CoreAudio standard audio driver. Be sure to use application software that is guaranteed to operate with this driver.
- Windows is a registered trademark or trademark of Microsoft Corporation in the United States and / or other countries. MAC is a registered trademark or trademark of Apple Incorporated in the United States and / or other countries.

Connection to an external effects processor

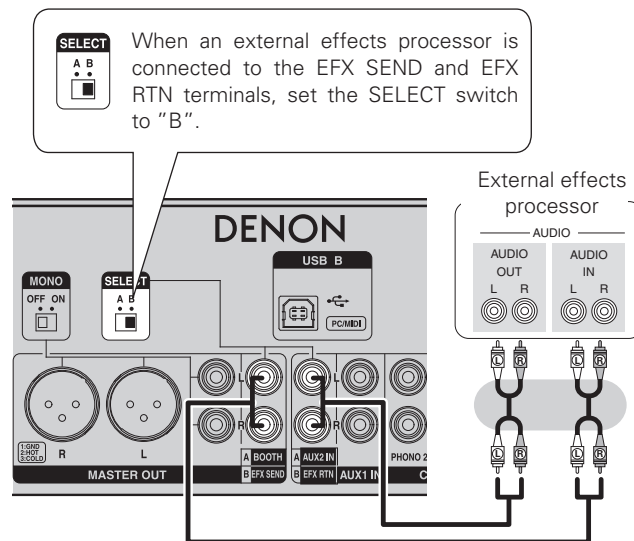

NOTE

The input and output volume levels are different for the input mode (SELECT) settings (A or B). Set the correct level to match the connected device.

Connecting the power cord

Insert the plug into the AC outlet.

NOTE

Insert the plug fully and securely into the socket. Incomplete connection to the power supply may cause damage to the unit, or noise.

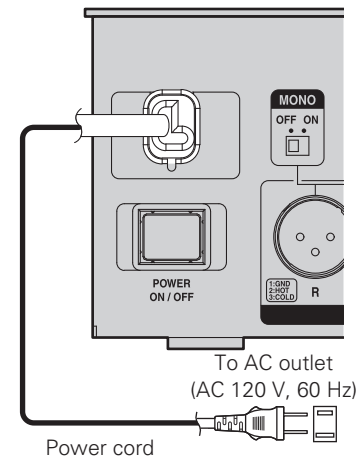

Basic operation

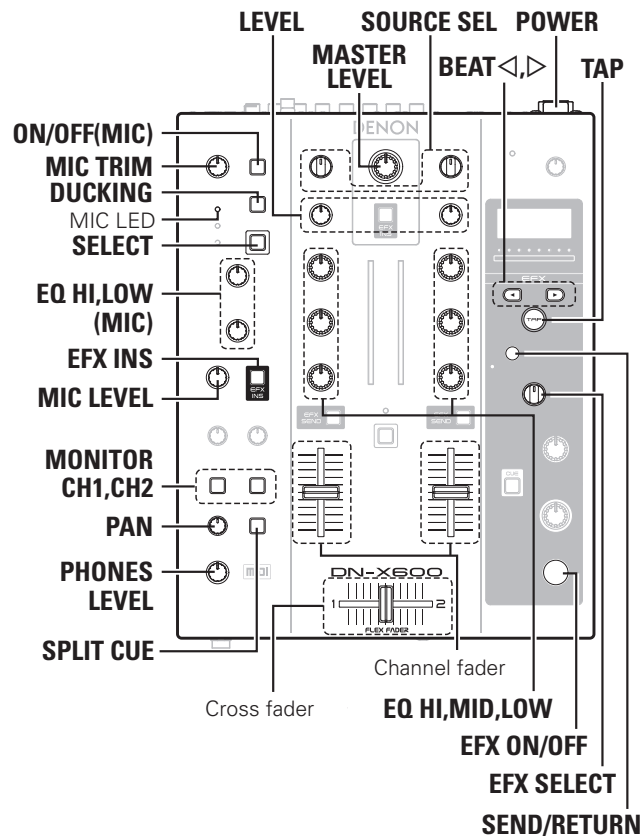

Basic operation

- 1 Press POWER.**
The power to the unit switches on, and the BPM display is shown.
- 2 Select the input source for each channel using SOURCE SEL.**
- 3 Adjust the input level using LEVEL.**
The input level is displayed in the cue master level meter.
- 4 Adjust the sound quality between EQ HI, MID, LOW .**
- 5 Adjust the volume using the channel fader and cross fader.**
- 6 Adjust the output level using MASTER LEVEL.**

MIC (Mic input)

- 1 Press ON/OFF (MIC).**
 - ON/OFF (MIC) lights up.
 - MIC input is activated.
- 2 Press SELECT to select MIC.**
The MIC LED is lit.
- 3 Adjust the mic input level using MIC TRIM.**
The optimum adjustment without distortion is at the position when the SIG/PK display is lit orange and occasionally lights red during microphone activity.
- 4 Adjust the mic sound quality using EQ HI and LOW.**
- 5 Adjust the mic output level using MIC LEVEL.**

- To apply effects to the mic input**
Press **EFX INS (MIC/AUX1)**.

- To activate the ducking function**

The ducking function attenuates the master output sound signal level when mic input is detected. It prevents the mic volume being covered by the music volume when a mic is used.

Press **DUCKING**.

- **DUCKING** LED is lit green.

Headphone monitor

There are two methods for headphone monitoring. Switch between the two as desired for use.

- 1 Press MONITOR CH1 or CH2 to select the source to monitor.**
The selected button lights up.
- 2 Press SPLIT CUE to select the monitoring method.**

SPLIT CUE mode ← → STEREO mode

SPLIT CUE mode

 - **SPLIT CUE** lights up.
 - The channel sound (CUE) selected in step 1 is outputted from the left headphone.
 - The master sound is outputted from the right headphone.
 - The sound is monaural sound.

STEREO mode

 - **SPLIT CUE** switches off.
 - The channel sound (CUE) selected in step 1 and master sound output in stereo.
- 3 Rotate PAN to adjust the balance between the CUE sound and master sound.**
- 4 Adjust the headphone volume using PHONES LEVEL.**

NOTE

When using headphones, be cautious to avoid prolonged loud volume in order to protect your ears.

Effector function

The unit is equipped with a powerful effector function that syncs various effects by detected BPM values measured by the input sound. You are also able to SEND multiple input channels simultaneously to the effector, enabling a wide range of acoustic effects for performance mixing.

Type of Effect and operation detail.

No	Effect Name	Details of Effect Operation
1	Reverb	Adds reverberation signals that are delayed according to the beat setting time.
2	Flanger	Adds signals whose delay time is altered in the LFO period in the beat settings.
3	Echo	Adds echo signals which are delayed by the time set in the beat settings.
4	Delay	Adds signals which are delayed by the time set in the beat settings. .
5	Loop	Initiates the same loop sampler process as the LOOP function of other Denon DJ products.
6	B.BREAKER (BeatBreaker)	Initiates partial insertion processing of the attack sounds of beats as per the beat pattern.
7	Filter	Varies the filter cut-off frequency using the beat setting time.
8	B.SCRATCH (BeatScratch)	Repeats standard playback of the beat setting time and reverse playback of the same beat setting time to produce a scratching effect.

* In order to achieve normal effects, set the BPM value to match the BPM of the musical composition.

Send/Return function

This unit can obtain effects from external effects processors and computers in addition to the built-in effects.

Required settings and connections

The settings and connections required for each effector are as shown in the following table.

Settings and connections				SEND/ RETURN display lamp color	Effector that can be used		
SELECT switch setting (Rear panel)		Connection to a Computer	This unit's effector		External Effect Processor	Computer software effector	
Input	Output						
A	BOOTH	AUX2	None	Off	-	-	-
B	EFX SEND	EFX RTN	Yes	Orange	✓		
B	EFX SEND	EFX RTN	None	Red (Dark)	✓		
B	EFX SEND	EFX RTN	-	Red	*1	✓	
A	BOOTH	AUX2	Yes	Green (Dark)	✓		
-	-	-	Yes	Green	*1		✓

*1: This unit's effector cannot be used.

Selecting the send/return function

Press **SEND/RETURN**.

Off ←→ On

- Switches to the SEND/RETURN mode.
- The SEND/RETURN display lamp color differs depending on the settings and connection status.

BeatBreaker function

This function breaks down the music signals in each bar into 16 quarter-beat sections, replaces the beats in these sections with a preset beat pattern, and then replays the musical signal to achieve an effect in which the original beat has been replaced with the new beat.

Details of operation

- The beat pattern is constructed of 16 blocks.
- The following 10 beat patterns are available.
- The sound when **EFX ON/OFF** is ON (marked "●" in the figure below) is played across 1 beat at the position marked by "○" in the figure below.

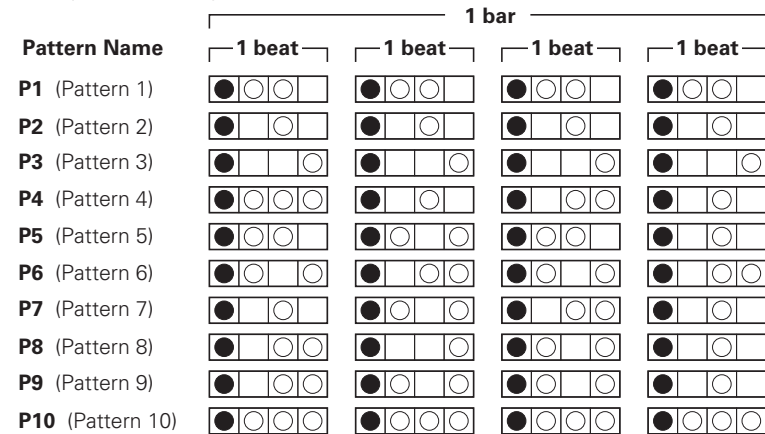

How to operate

1 Set the **EFX SELECT** to "B.BREAKER".

2 Select the beat pattern using **BEAT** ◀, ▶.

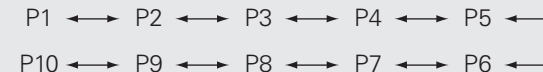

3 Press **EFX ON/OFF** to switch the effect ON.

- **EFX ON/OFF** lights up.
- When the effect is ON, press **EFX ON/OFF** to turn the effect OFF.

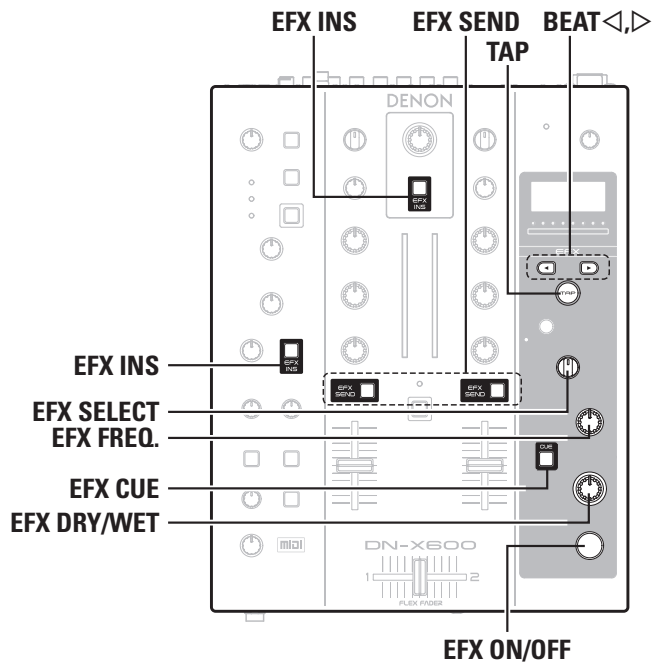

Operating the effector

1 Press **EFX SEND** for the channel that you want to apply the effector to.

- The input source sound signal is sent to the effector.
- To apply the effector to the mic input or master output, press **EFX INS**.

2 Set the BPM.

BPM is the base value for the effector. To obtain normal effects, match the BPM value with the BPM of the track. The following three setting methods are available for the BPM value.

Setting Auto BPM

- 1 Press **TAP** for more than 1 second.
 - "Auto" is shown in the display.
 - **TAP** LED lights up green.
- 2 Press **TAP** (short push).
 - The measured auto BPM value is displayed, and that value is locked.
 - **TAP** LED switches off.

Setting Manual In BPM

- 1 Press **TAP** for more than 2 seconds.
 - The BPM value in the display flashes.
- 2 Press **BEAT** to set the desired BPM value.
- 3 Press **TAP**.
 - The setting is complete.

Setting Manual TAP BPM

- 1 Repeatedly press **TAP** in time with the input source rhythm.
 - The BPM value for the interval between button presses is set.

3 Select the effector using **EFX SELECT** .

4 Press **EFX ON/OFF** to switch the effect ON.

- **EFX ON/OFF** lights up.
- Press **EFX ON/OFF** again to turn the effect off.

Adjusting the effects

Rotate **EFX FREQ.**

- Adjust the filter cut off frequency, and adjust the frequency band within which to apply the effect.
- This does not operate during SEND/RTN.

To monitor the effect sound

Press **EFX CUE**.

Off ← → On

When this is switched on, the effect volume can be monitored even when the effect is off. (Excluding ECHO and REVERB.)

To adjust the proportion of original volume and effect volume

Rotate **EFX DRY WET**.

- When rotated in the DRY direction, the original volume proportion increases.
- When rotated in the WET direction, the effect volume proportion increases.

Beat setting

Adjust the beats based on the set BPM value. The setting range for beats differs depending on the effector.

Press **BEAT** to select the set beat value.

The beat display switches.

[Selectable range]

- When **REVERB/FLANGER/B-BREAKER/FILTER/B-SCRATCH** are selected:
1/4 - 32
- When **ECHO/DELAY/LOOP** are selected:
1/16 - 4

Fader start function

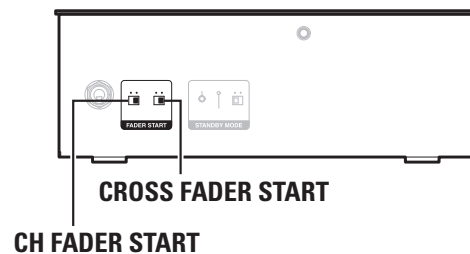
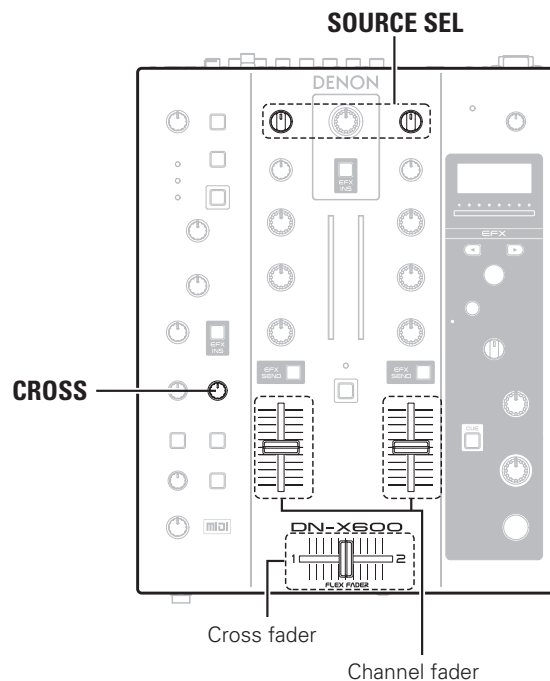

The fader start function controls playback/pause of the CD/Media player using the fader control on the unit by sending a fader command to the player.

Connect the FADER terminal on this unit to a FADER compatible DJ player using a 3.5mm stereo mini plug cable in advance.

Channel fader start

- 1** Switch the **CH FADER START** to "ON".
- 2** Adjust **SOURCE SEL** to match the CD input ("CD1" or "CD2").
- 3** Move the channel fader knob for the CD input channel to the lowest position.
The player switches to CUE up status.
- 4** Move the channel fader knob upwards.
The CD player starts playback.
If the channel fader knob is then moved all the way down, the player stops.

Cross fader start

This section explains how to start playback for a CD/Media player connected to CH1.

- 1** Switch the **CROSS FADER START** to "ON".
- 2** Turn the CH1 **SOURCE SEL** to "CD1".
- 3** Slide the cross fader all the way to the "2" (CH2) position.
- 4** The player switches to CUE up status.
- 5** Set **CROSS** to a position other than "THRU".
- 6** Move the cross fader in the opposite direction.
The player starts playback.

NOTE

If you set **CROSS** to the "THRU" position, the cross fader start function will be disabled.

Fader curve adjustment

Adjusts the startup response of the channel fader/cross fader.

Adjust the channel fader curve

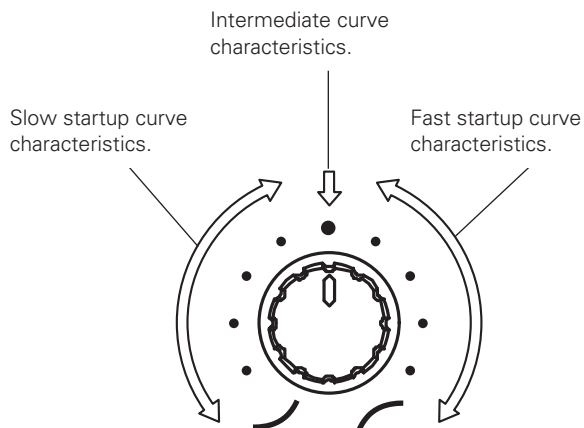

- CH1 and CH2 have the same curve characteristics.

Adjust the cross fader curve

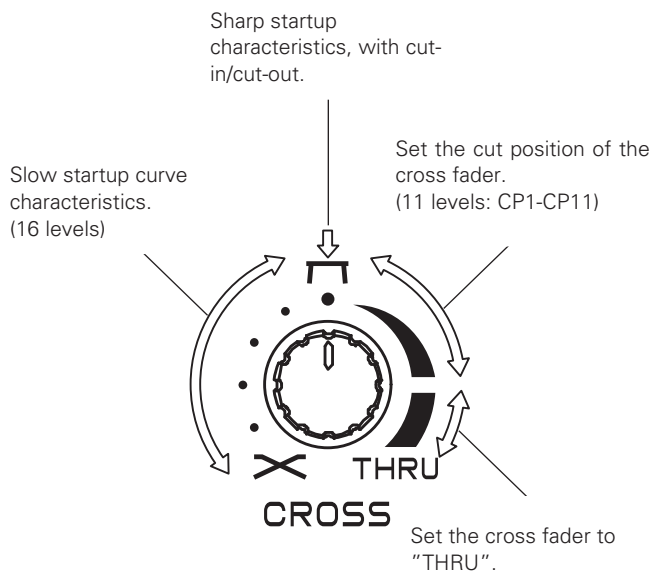

Adjusting the cross fader torque

1 Remove the rubber cap on the front panel.

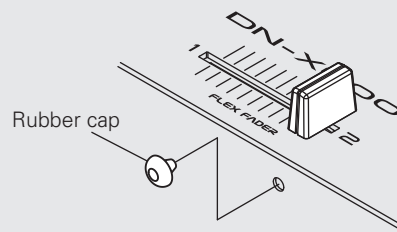

2 Move the cross fader to the far right edge so that the screwdriver will line up with the screw head inside.

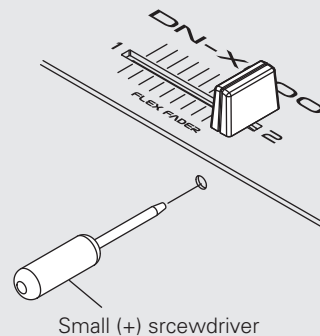

3 Using a Phillips screwdriver, adjust the sliding torque.

- Rotate to the right: Increases the sliding torque so that the cross fader resistance is increased.
- Rotate to the left: Decreases the sliding torque so that the cross fader resistance is decreased.

4 After completing the adjustment, replace the rubber cap on the front panel.

NOTE

The cross fader is constructed of precision parts. Over tightening or over loosening the cross fader may affect the performance of the cross fader, or may damage it.

USB settings

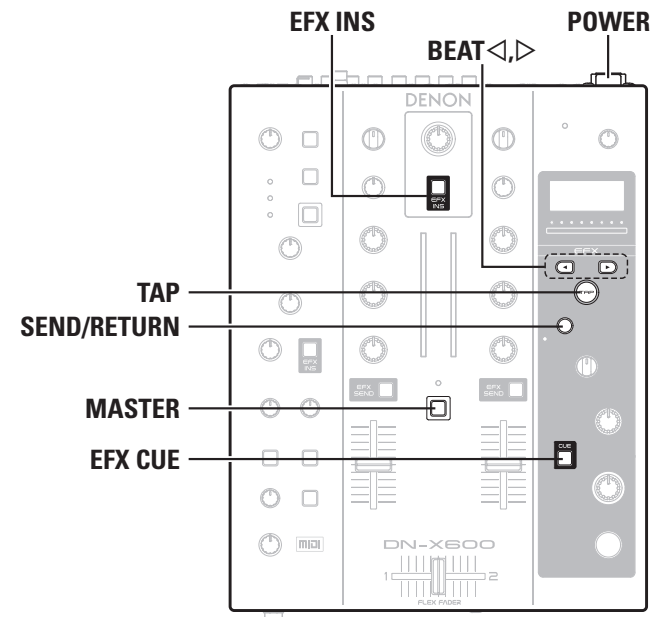

Computer OS settings

Before connecting a computer to this unit, set the OS of the computer that you want to connect with this unit.

- The default setting is "PC".
- Settings cannot be changed when the computer is connected.

1 While pressing EFX CUE, press BEAT <,>.

The mode changes to OS setting mode.

2 Press BEAT <,> to select the OS.

PC ← → MAC
(Windows OS) (Mac OS)

3 Press TAP.

The OS setting is entered.

- To cancel the settings, press SEND/RETURN.

USB device mode

The USB device mode (USB B terminal) supports the following functions.

- USB audio interface function
- USB MIDI interface function

Using this function, music files stored on the computer can be played back through this unit, and sounds played through this unit can be saved to the computer.

USB audio input/output

This unit is equipped with a maximum 8ch (stereo 4 system), 24bit, 96kHz USB audio input/output sound card function. The sampling frequency can be selected from 44.1k, 48k, and 96kHz.

- The default setting is 96kHz. If your software does not support 96kHz sampling, use the procedure below to switch the sampling frequency.

Selecting the sampling frequency

- 1** When the power is OFF, press **POWER** while holding down **EFX INS**.

The power switches on, and the mode switches to sampling frequency mode.

- 2** Press **BEAT** \triangleleft or \triangleright to display the sampling frequency that you want to set.



- 3** Press **TAP**.
The displayed sampling frequency is selected and saved.

- 4** Press **POWER** to turn the power off, and then press **POWER** again to turn the power on again.
 - When this unit restarts, the sampling frequency setting is set.

NOTE

- For Windows PC users:
If ASIO driver version 1.01 is already installed for other Denon DJ product, uninstall it first, and then install the 2.1x version found on the included CD-ROM or our website. You should do this before connecting the DN-X600 to your computer.
- Set the computer OS to match the computer you are using ((page 13) "Computer OS Settings").

USB audio output

The following signals are always outputted from the 4-system stereo USB audio output. Select the desired signals through your software application on your computer.

- USB 1/2 CH1 or DVS CH1
- USB 3/4 CH2 or DVS CH2
- USB 5/6 MIC or USB EFX SEND
- USB 7/8 REC

USB audio input mode settings

For the USB audio signal input mode, there are 2 different methods of mixing processes, channel, "CH" and master, "MAS". Set them accordingly as listed below.

- The default mode is "CH INPUT mode".

- 1** While pressing **MASTER**, press **BEAT** \triangleleft , \triangleright .
The mode changes to USB audio setting mode.

- 2** Press **BEAT** \triangleleft , \triangleright to select the USB audio mode.

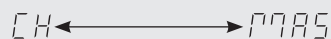

CH INPUT mode

MASTER mode

CH INPUT mode

Mixes the sources input from the channels.

Set this mode if you do not want to use the mixer function supplied in the DJ software.

- USB channel 1 and 2 inputs → Input channel 1
- USB channel 3 and 4 inputs → Input channel 2
- USB channel 5 and 6 inputs → USB EFX RTN
- USB channel 7 and 8 inputs → Master bus

MASTER mode

DJ software mixer output is mixed in the DN-X600 internal bus. Mixing is performed with both the DJ software mixer function and the DN-X600.

Assign each USB audio input signal to the following busses.

- USB channel 1 and 2 inputs → Master bus
- USB channel 3 and 4 inputs → Cue monitor bus
- USB channel 5 and 6 inputs → USB EFX RTN
- USB channel 7 and 8 inputs → Master bus

- 3** Press **TAP**.
The USB audio mode setting is entered and saved.
 - To cancel the settings, press **SEND/RETURN**.

- 4** Set the DJ software audio output settings to match the USB audio input mode settings.

- For details on how to configure the settings, see the instruction manual for the DJ software.

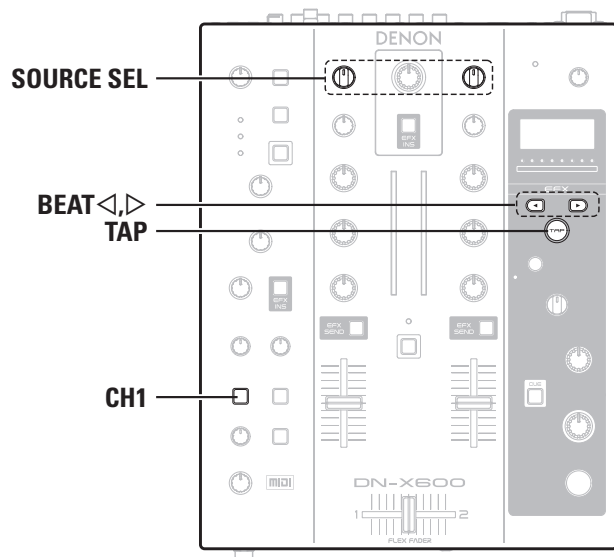

MIDI command output

This unit supports USB MIDI output.
Almost all MIDI control functions and MIDI clocks are supported.

MIDI output channel settings

- The default MIDI setting channel is "CH1".

1 While pressing **CH1**, press **BEAT** \triangleleft , \triangleright .
The mode changes to the channel setting mode.

2 Press **BEAT** \triangleleft , \triangleright to select the MIDI channel to output.

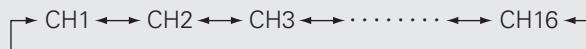

- To cancel the settings, press **SEND/RETURN**.

3 Press **TAP**.
The MIDI output channel is set and saved.

MIDI clock synchronization

If the MIDI clock Input BPM signal is detected from the computer when AUTO BPM mode is being used, this unit automatically switches to operate using the MIDI clock input BPM instead.

Playback using the DVS function

The DVS (Digital Vinyl System) function performs playback operations of music files such as MP3 or WAV that are stored on the computer by operating the software timecode signal from a turntable or CD/Media player.

If this function is used, you can use the player's outstanding operability to play back music files on the computer.

To use the DVS function, you need the following devices.

- Computer with DVS software installed
- Time code disc that accompanied the DVS software
- A CD/Media player or vinyl turntable

Connections

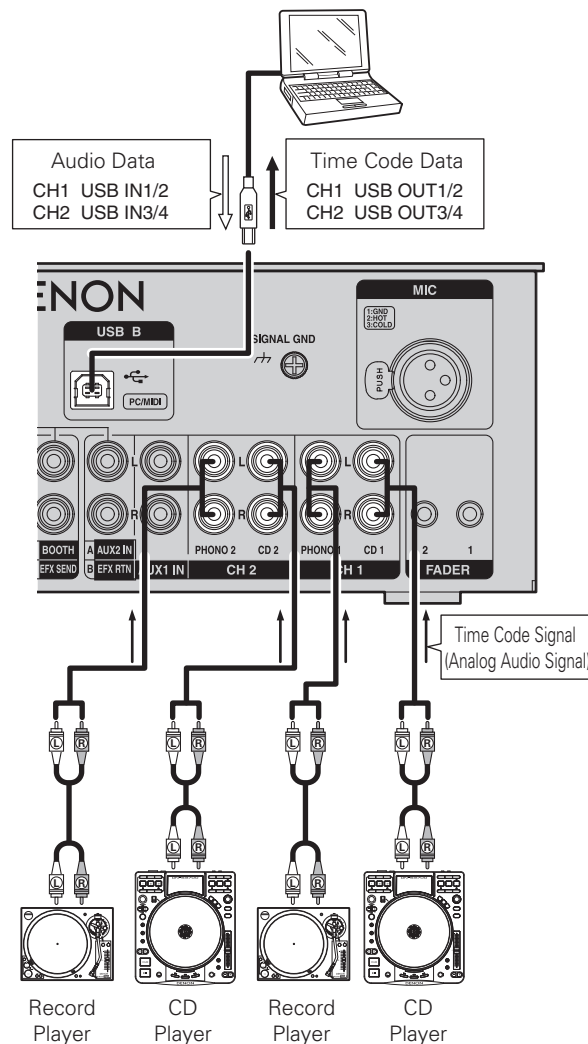

DVS playback

Configure the DVS software beforehand.

- For details on how to configure the settings, see the instruction manual for the DVS software.

1 Set the **SOURCE SEL** of the channel to be used to "DVS".

- The mode switches to the selection mode for the input source output to the computer.
 - CH1 Input: Displays "1C" or "1P".
 - CH2 Input: Displays "2C" or "2P".
 ("C" indicates CD input, "P" indicates PHONO input.)
- Switching between "C" and "P" for each channel.
 - CH1 Change: Press **BEAT** \triangleleft .
 - CH2 Change: Press **BEAT** \triangleright .

2 Press **TAP**.

The input source for each channel is set and saved.

3 Start the DVS software on the computer, and prepare it for playback.

4 Playback the time code disc on the vinyl turntable or CD player connected to the channel to be used.

- This unit outputs the input time code signal to the computer.
- The computer receives the time code signal, and starts playback.
- For details on operations during playback, see the instruction manual for the DVS software.

5 Adjust the volume etc. for the connected channel.

□ MIDI command list

Send command

	items	MIDI command			Message type	Notes
		Command	Number	Value		
CH1	EQ HIGH VR	0xBn	0x02	0x00 to 0x7F	Control Change	0-127
	EQ MID VR	0xBn	0x03	0x00 to 0x7F	↑	↑
	EQ LOW VR	0xBn	0x04	0x00 to 0x7F	↑	↑
	FADER	0xBn	0x05	0x00 to 0x7F	↑	↑
	EFFECT SEND	SW ON : 0x9n/SW OFF : 0x8n	0x01	SW ON : 0x40/SW OFF : 0x00	Note ON/OFF	
	CUE	SW ON : 0x9n/SW OFF : 0x8n	0x03	SW ON : 0x40/SW OFF : 0x00	↑	
CH2	EQ HIGH VR	0xBn	0x08	0x00 to 0x7F	Control Change	0-127
	EQ MID VR	0xBn	0x09	0x00 to 0x7F	↑	↑
	EQ LOW VR	0xBn	0x0A	0x00 to 0x7F	↑	↑
	FADER	0xBn	0x0B	0x00 to 0x7F	↑	↑
	EFFECT SEND	SW ON : 0x9n/SW OFF : 0x8n	0x05	SW ON : 0x40/SW OFF : 0x00	Note ON/OFF	
	CUE	SW ON : 0x9n/SW OFF : 0x8n	0x07	SW ON : 0x40/SW OFF : 0x00	↑	
CROSS FADER	CROSS FADER	0xBn	0x16	0x00 to 0x7F	Control Change	0-127
MASTER	MASTER LEVEL VR	0xBn	0x19	0x00 to 0x7F	↑	↑
	BOOTH LEVEL VR	0xBn	0x1B	0x00 to 0x7F	↑	↑
	EFFECT INSERT	SW ON : 0x9n/SW OFF : 0x8n	0x11	SW ON : 0x40/SW OFF : 0x00	Note ON/OFF	
EFFECT	BEAT UP	SW ON : 0x9n/SW OFF : 0x8n	0x16	SW ON : 0x40/SW OFF : 0x00	↑	
	BEAT DOWN	SW ON : 0x9n/SW OFF : 0x8n	0x17	SW ON : 0x40/SW OFF : 0x00	↑	
	TAP	SW ON : 0x9n/SW OFF : 0x8n	0x18	SW ON : 0x40/SW OFF : 0x00	↑	
	SEND/RETURN	SW ON : 0x9n/SW OFF : 0x8n	0x19	SW ON : 0x40/SW OFF : 0x00	↑	
	CUE	SW ON : 0x9n/SW OFF : 0x8n	0x1A	SW ON : 0x40/SW OFF : 0x00	↑	
	EFFECT ON/OFF	SW ON : 0x9n/SW OFF : 0x8n	0x1D	SW ON : 0x40/SW OFF : 0x00	↑	
	PARAMETER VR	0xBn	0x1C	0x00 to 0x7F	↑	0-127
	DRY/WET VR	0xBn	0x1D	0x00 to 0x7F	↑	↑
MIC/PHONES	MIC EQ HIGH VR	0xBn	0x21	0x00 to 0x7F	Control Change	↑
	MIC EQ LOW VR	0xBn	0x22	0x00 to 0x7F	↑	↑
	MIC SEND LEVEL VR	0xBn	0x23	0x00 to 0x7F	↑	↑
	MIC TRIM ON/OFF	SW ON : 0x9n/SW OFF : 0x8n	0x26	SW ON : 0x40/SW OFF : 0x00	Note ON/OFF	
	MIC EFFECT INSERT	SW ON : 0x9n/SW OFF : 0x8n	0x28	SW ON : 0x40/SW OFF : 0x00	↑	
	DUCKING	SW ON : 0x9n/SW OFF : 0x8n	0x2A	SW ON : 0x40/SW OFF : 0x00	↑	

* The "Command" "n" indicates the MIDI channel number (n=0 – F).

Troubleshooting

If a problem should arise, first check the following:

1. Are the connections correct?

2. Is the set being operated as described in this owner's manual?

3. Is the external device (player or effects processor) operating correctly?

If this unit does not operate properly, check the items listed in the table below.

If the symptom is not covered on the check list, contact your dealer or service centers.

Service centers are listed at <http://www.d-mpro.com>.

- When contacting your dealer or service center, be sure to inform them of the software version number. The software version number is shown on the display by pressing the **SPLIT CUE** button and **BEAT** button at the same time.

Symptom	Cause/Solution	Page
Power does not turn on.	<ul style="list-style-type: none"> • Check whether the power plug is correctly inserted into the power outlet. 	8
The power switch is ON, but the unit power is off.	<ul style="list-style-type: none"> • The unit is in standby mode. Press the RESTART button. 	4
There is no sound, or the sound is too quiet.	<ul style="list-style-type: none"> • Check the connections for all devices. • Change the source selection switch to the device currently being played. 	6 – 8 9
	<ul style="list-style-type: none"> • The mic ducking function is operating. Set the DUCKING switch to "OFF". 	9
The sound is distorted.	<ul style="list-style-type: none"> • Adjust the master output adjustment knob. 	9
	<ul style="list-style-type: none"> • Adjust the input level adjustment knob. 	9
Fader start cannot be performed on the CD player.	<ul style="list-style-type: none"> • Use the stereo mini terminal to connect the CD player to this unit. 	6
	<ul style="list-style-type: none"> • Set the fader start switch to "ON". 	12
This unit does not operate properly, or there is no sound.	<ul style="list-style-type: none"> • Check the connections for all devices. 	6 – 8
	<ul style="list-style-type: none"> • Check whether the sound source, audio device, application, and OS volume settings are correctly adjusted. 	9, 14
This unit does not operate properly, or there is no sound.	<ul style="list-style-type: none"> • Select a suitable device. 	–
	<ul style="list-style-type: none"> • Match the unit settings with the application settings. 	14
	<ul style="list-style-type: none"> • WAV files become mixed if the sampling frequency and bit number are different. Depending on the audio application used, WAV files that have different sampling frequencies or bit numbers cannot be played simultaneously. 	–
	<ul style="list-style-type: none"> • If another USB device is connected, connect only this unit and check whether it operates correctly. 	–
	<ul style="list-style-type: none"> • Use the USB cable provided. Also, check whether the USB connector of the connected computer is USB2.0 (Hi-Speed) compatible. 	8

Symptom	Cause/Solution	Page
Sound cuts out or is distorted.	<ul style="list-style-type: none"> • Exit any unneeded applications. • When multiple WAV files are played back simultaneously, the playback sound may cut out depending on the computer specifications. Try playing back 1 WAV file. 	– –

Specifications

Audio	(0 dBu=0.775 Vrms, 0 dBV =1 Vrms)	Load impedance:	Over 600 Ω
• PHONO inputs	2 Stereo Unbalanced RCA terminal	Level:	+ 4 dBu (Max + 24 dBu)
Input impedance:	47 kΩ	Frequency response:	20 Hz – 20 kHz(±0.5 dB)
Level:	-40 dBV(10 mV)	THD:	Less than 0.05%
Signal to Noise ratio:	89 dB	Crosstalk:	Less than -100 dB (1 kHz)
• CD inputs	2 Stereo Unbalanced RCA terminal	Unbalanced:	Stereo RCA terminal
Input impedance:	10 kΩ	Load impedance:	10 kΩ
Level:	0 dBV	Level:	0 dBu (Max + 20dBu)
Signal to Noise ratio:	100 dB	• EFX SEND/BOOTH Output	Stereo RCA terminal
• Equalizer (LINE)	3 Band	Load impedance:	10 kΩ or more
Channel EQ Adjustment Range:	HI (High Range) : -∞, -90 dB – +10 dB MID (Medium Range) : -∞, -90 dB – +10 dB LOW (Low Range) : -∞, -90 dB – +6 dB	Level:	BOOTH: 0dBu (Max + 20dBu) EFX SEND:-10dBV (Max +10dBV)
• AUX1 Input	1 Stereo RCA Terminal	• Headphone output	Stereo
Input impedance:	10 kΩ	Load impedance:	40 Ω
Level:	0 dBV	Level:	100 mW
• EFX RETURN AUX2 inputs	1 Stereo RCA Terminal	• USB audio output	4 Stereo(8 Monaural) 24bit, 44.1/48/96 kHz USB B
Input impedance:	10 kΩ	General	
Level:	AUX2:0 dBV EFX RETURN:-10 dBV	USB MIDI I/O:	IN:1ch, OUT:1ch MIDI1.0, MIDI Clock USB B
• MIC inputs	Monaural	CH Meter:	PPM 10 Point LED-20 – + 10 dB, Peak
MIC:	Balanced XLR (1: Ground, 2: Hot, 3: Cold)	MASTER Meter:	PPM 10 Point LED-20 – + 10 dB, Peak
Input impedance:	5kΩ	CH Fader:	45 mm Slim Type fader
Level:	-60 – +20 dBu	Cross Fader:	45 mm FLEX Fader (Fader Torque Adjustable)
EIN:	-126 dBu or less (Rs=150Ω)	• Power supply:	
CMRR:	89 dB or more (1 kHz)	U.S.A. and Canada models:	AC 120 V, 60 Hz
• Equalizer (MIC/AUX1)	2 Band	European,U.K. and Asia/ Pacific models:	AC 230 V, 50 Hz
Adjustment Range:	HI (High Range) :-15 – +15 dB LOW (Low Range) :-15 – +15dB	Power consumption:	24 W (Less than 0.3 W during standby)
• USB audio inputs	4 Stereo(8 Monaural) 24 bit, Fs:44.1/48/96 kHz USB B	Operating temperature:	+5 °C – +35 °C
• MASTER output Balanced:	Stereo, balanced XLR terminal (1: Ground, 2: Hot, 3: Cold)	Operating humidity:	25 % – 85 %
DA converter:	32 bit 128-times oversampling advanced segment	Storage temperature:	-20 °C – 60 °C

Dimensions	
Width:	250 mm / 9.8"
Height:	315 mm / 12.4"
Depth:	90 mm / 3.5"
Weight:	4.0 kg (8 lbs 13.1 oz)

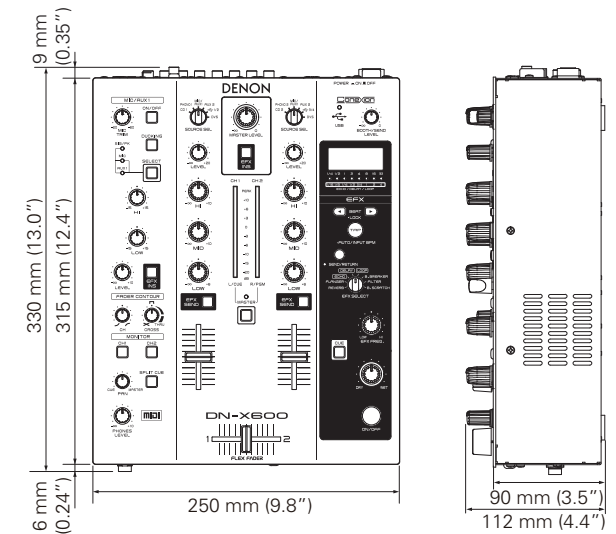

* For the purpose of improvement, the specifications and design are subject to change without notice.

Index

A

Automatic standby function 4

B

Beat 11

BeatBreaker 10

Beat pattern 10

C

Cable 6

 Balanced cable 6

 RCA pin plug cable 6

 Stereo mini plug cable 6

 USB cable 6

Channel fader 12, 13

Connection 6

 Active speakers 7

 Computer 8

 External effects processor 8

 Main balance power amp 7

 Main unbalance power amp 7

 Mic connection 7

 Power cord 8

Cross fader 12, 13

D

Ducking 9

DVS 15

E

Effector 10, 11

F

Fader start 12

Front panel 4

H

Headphone monitor 9

M

MIDI command 15, 16

P

Power on/off (standby) 9

R

Rear panel 5

S

Selecting the sampling frequency 14

Send/Return function 10

T

Top panel 3

U

USB audio 14

USB settings 13

System diagram

DNX600 Signal System Chart

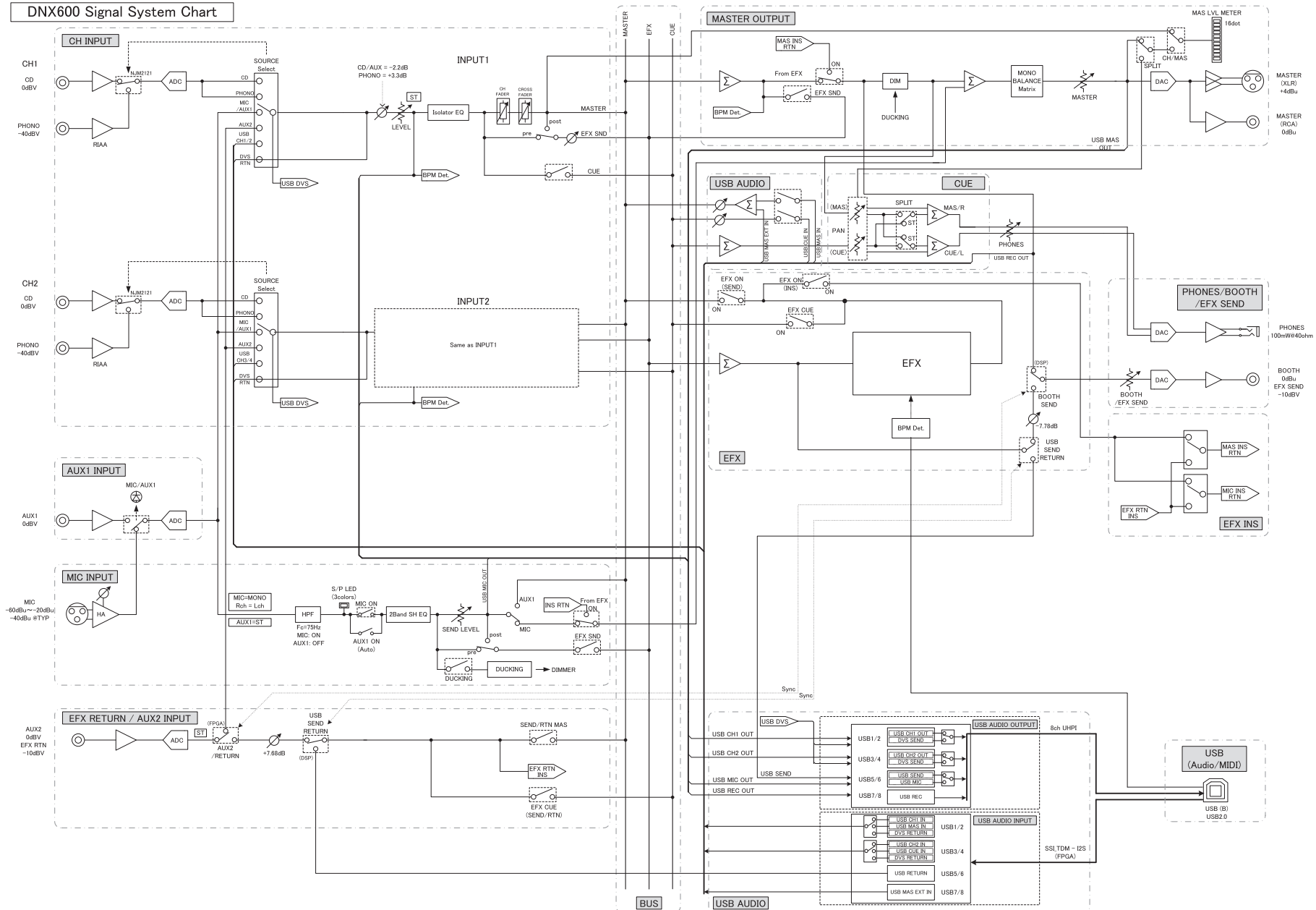

Before use
Part names and functions
Connections
Basic operations
Effector function
Fader function
USB settings
Troubleshooting
specifications
Index
System diagram

D&M Holdings Inc.

Free Manuals Download Website

<http://myh66.com>

<http://usermanuals.us>

<http://www.somanuals.com>

<http://www.4manuals.cc>

<http://www.manual-lib.com>

<http://www.404manual.com>

<http://www.luxmanual.com>

<http://aubethermostatmanual.com>

Golf course search by state

<http://golfingnear.com>

Email search by domain

<http://emailbydomain.com>

Auto manuals search

<http://auto.somanuals.com>

TV manuals search

<http://tv.somanuals.com>