

INSTRUCTION MANUAL

DEWALT®

D26676-XE
1.5 mm PLANER



Definitions: Safety Guidelines

The definitions below describe the level of severity for each signal word. Please read the manual and pay attention to these symbols.

⚠DANGER: Indicates an imminently hazardous situation which, if not avoided, **will** result in **death or serious injury**.

⚠WARNING: Indicates a potentially hazardous situation which, if not avoided, **could** result in **death or serious injury**.

⚠CAUTION: Indicates a potentially hazardous situation which, if not avoided, **may** result in **minor or moderate injury**.

NOTICE: Indicates a practice **not related to personal injury** which, if not avoided, **may** result in **property damage**.

IF YOU HAVE ANY QUESTIONS OR COMMENTS ABOUT THIS OR ANY DEWALT TOOL, CALL US AT: **1800 338 002** (Aust) or **0800 339 258** (NZ).

Technical Data

D26676-XE		
Voltage	V	230
Frequency	Hz	50
Power output	W	550
No-load/rated speed	min ⁻¹	17,000
Depth of cut	mm	1.5
Cutting width	mm	82
Rabetting depth	mm	9.0
Weight	kg	2.8
L_{pa} (sound pressure)	dB(A)	88
K_{pa} (sound pressure uncertainty)	dB(A)	3
L_{wa} (sound power)	dB(A)	99
K_{wa} (sound power uncertainty)	dB(A)	3

Vibration total values (triax vector sum) determined according to EN 60745:

Vibration emission value a_h		
$a_h =$	m/s ²	1.8
Uncertainty K =	m/s ²	1.5

The vibration emission level given in this information sheet has been measured in accordance with a standardised test given in EN 60745 and may be used to compare one tool with another. It may be used for a preliminary assessment of exposure.

⚠ WARNING: The declared vibration emission level represents the main applications of the tool. However if the tool is used for different applications, with different accessories or poorly maintained, the vibration emission may differ. This may significantly increase the exposure level over the total working period.

An estimation of the level of exposure to vibration should also take into account the times when the tool is switched off or when it is running but not actually doing the job. This may significantly reduce the exposure level over the total working period.

Identify additional safety measures to protect the operator from the effects of vibration such as: maintain the tool and the accessories, keep the hands warm, organisation of work patterns.

SAFETY INSTRUCTIONS FOR POWER TOOLS

When using power tools, always observe the safety regulations applicable in your country to reduce the risk of fire, electric shock and personal injury. Read the following safety instructions before attempting to operate this product. Keep these instructions in a safe place.



WARNING: To reduce the risk of injury, user must read the instruction manual.

GENERAL POWER TOOL SAFETY WARNINGS



WARNING! Read all safety warnings and all instructions Failure to follow the warnings and instructions may result in electric shock, fire and/or serious injury.

SAVE ALL WARNINGS AND INSTRUCTIONS FOR FUTURE REFERENCE

The term "power tool" in the warnings refers to your mains-operated (corded) power tool or battery-operated (cordless) power tool.

1) WORK AREA SAFETY

- a) **Keep work area clean and well lit.** Cluttered or dark areas invite accidents.
- b) **Do not operate power tools in explosive atmospheres, such as in the presence of flammable liquids, gases or dust.** Power tools create sparks which may ignite the dust or fumes.
- c) **Keep children and bystanders away while operating a power tool.** Distractions can cause you to lose control.

2) ELECTRICAL SAFETY

- a) **Power tool plugs must match the outlet. Never modify the plug in any way. Do not use any adapter plugs with earthed (grounded) power tools.** Unmodified plugs and matching outlets will reduce risk of electric shock.
- b) **Avoid body contact with earthed or grounded surfaces such as pipes, radiators, ranges and refrigerators.** There is an increased risk of electric shock if your body is earthed or grounded.
- c) **Do not expose power tools to rain or wet conditions.** Water entering a power tool will increase the risk of electric shock.
- d) **Do not abuse the cord. Never use the cord for carrying, pulling or unplugging the power tool. Keep cord away from heat, oil, sharp edges or moving parts.** Damaged or entangled cords increase the risk of electric shock.
- e) **When operating a power tool outdoors, use an extension cord suitable for outdoor use.** Use of a cord suitable for outdoor use reduces the risk of electric shock.
- f) **If operating a power tool in a damp location is unavoidable, use a residual current device (RCD) protected supply.** Use of an RCD reduces the risk of electric shock.

3) PERSONAL SAFETY

- a) **Stay alert, watch what you are doing and use common sense when operating a power tool. Do not use a power tool while you are tired or**

under the influence of drugs, alcohol or medication. A moment of inattention while operating power tools may result in serious personal injury.

- b) **Use personal protective equipment. Always wear eye protection.** Protective equipment such as dust mask, non-skid safety shoes, hard hat, or hearing protection used for appropriate conditions will reduce personal injuries.
- c) **Prevent unintentional starting. Ensure the switch is in the off position before connecting to power source and/or battery pack, picking up or carrying the tool.** Carrying power tools with your finger on the switch or energising power tools that have the switch on invites accidents.
- d) **Remove any adjusting key or wrench before turning the power tool on.** A wrench or a key left attached to a rotating part of the power tool may result in personal injury.
- e) **Do not overreach. Keep proper footing and balance at all times.** This enables better control of the power tool in unexpected situations.
- f) **Dress properly. Do not wear loose clothing or jewellery. Keep your hair, clothing and gloves away from moving parts.** Loose clothes, jewellery or long hair can be caught in moving parts.
- g) **If devices are provided for the connection of dust extraction and collection facilities, ensure these are connected and properly used.** Use of dust collection can reduce dust-related hazards.

4) POWER TOOL USE AND CARE

- a) **Do not force the power tool. Use the correct power tool for your application.** The correct power tool will do the job better and safer at the rate for which it was designed.
- b) **Do not use the power tool if the switch does not turn it on and off.** Any power tool that cannot be controlled with the switch is dangerous and must be repaired.
- c) **Disconnect the plug from the power source and/or the battery pack from the power tool before making any adjustments, changing accessories, or storing power tools.** Such preventive safety measures reduce the risk of starting the power tool accidentally.
- d) **Store idle power tools out of the reach of children and do not allow persons unfamiliar with the power tool or these instructions to operate the power tool.** Power tools are dangerous in the hands of untrained users.

- e) **Maintain power tools. Check for misalignment or binding of moving parts, breakage of parts and any other condition that may affect the power tool's operation. If damaged, have the power tool repaired before use.** Many accidents are caused by poorly maintained power tools.
- f) **Keep cutting tools sharp and clean.** Properly maintained cutting tools with sharp cutting edges are less likely to bind and are easier to control.
- g) **Use the power tool, accessories and tool bits, etc. in accordance with these instructions, taking into account the working conditions and the work to be performed.** Use of the power tool for operations different from those intended could result in a hazardous situation.

5) SERVICE

- a) **Have your power tool serviced by a qualified repair person using only identical replacement parts.** This will ensure that the safety of the power tool is maintained.

Electrical Safety

The electric motor has been designed for one voltage range only. Always check that the power supply corresponds to the voltage on the rating plate. 220–240 V AC means your tool will operate on alternating current. Operation at a voltage outside this range can cause loss of power and can result in overheating. All DeWALT tools are factory tested; if this tool does not operate, check the power supply. Your DeWALT tool is double insulated, therefore no earth wire is required.

- **Young children and the infirm.** This appliance is not intended for use by young children or infirm persons without supervision.
 - This appliance is not intended for use by persons (including children) with reduced physical, sensory or mental capabilities, or lack of experience and knowledge, unless they have been given supervision or instruction concerning use of the appliance by a person responsible for their safety.
 - Children should be supervised to ensure that they do not play with the appliance.
- **Replacement of the supply cord.** If the supply cord or plug is damaged, it must be replaced by the manufacturer or an authorised DeWALT Service Centre in order to avoid a hazard.

Extension Cords

⚠ CAUTION: Use only extension cords that are approved by the country's Electrical Authority. Before using extension cords, inspect them for loose or exposed wires, damaged insulation and defective fittings. Replace the cord if necessary.

Planer Safety Rules

- **Wait for the cutter to stop before setting the tool down.** An exposed cutter may engage the surface leading to possible loss of control and serious injury.
- **Use clamps or other practical way to secure and support the workpiece to a stable platform.** Holding the work by your hand or against the body is unstable and may lead to loss of control.
- **Hold the power tool by insulated gripping surfaces only, because the cutter may contact its own cord.** Cutting a "live" wire may make exposed metal parts of the power tool "live" and could give the operator an electric shock.
- **Never reach under the tool for any reason unless it is turned off and unplugged. BLADES ARE EXPOSED AND EXTREMELY SHARP.**
- **Planer blades are extremely sharp.** Handle with great care.
- Use this tool for working with wood and wood products only.
- **Air vents often cover moving parts and should be avoided.** Loose clothes, jewellery or long hair can be caught in moving parts.

⚠ WARNING: We recommend the use of a residual current device with a residual current rating of 30mA or less.

⚠ WARNING: ALWAYS wear approved protective safety equipment complying with the following standards:

- Eye protection: AS/NZS1337 Eye Protectors for Industrial Applications;
- Hearing protection: AS/NZS1270 Acoustics – Hearing Protection;
- Respiratory protection: AS/NZS1716 Respiratory Protective Devices.

⚠ WARNING: Some dust created by power sanding, sawing, grinding, drilling, and other construction activities contains chemicals known to cause cancer, birth defects or other reproductive harm. Some examples of these chemicals are:

- lead from lead-based paints,
- crystalline silica from bricks and cement and other masonry products, and
- arsenic and chromium from chemically-treated lumber.

Your risk from these exposures varies, depending on how often you do this type of work. To reduce your exposure to these chemicals: work in a well ventilated area, and work with approved safety equipment, such as those dust masks that are specially designed to filter out microscopic particles.

- **Avoid prolonged contact with dust from power sanding, sawing, grinding, drilling, and other construction activities. Wear protective clothing and wash exposed areas with soap and water.** Allowing dust to get into your mouth, eyes, or lay on the skin may promote absorption of harmful chemicals.

⚠ WARNING: Use of this tool can generate and/or disburse dust, which may cause serious and permanent respiratory or other injury. Always use AS/NZS1716 approved respiratory protection appropriate for the dust exposure. Direct particles away from face and body.

⚠ WARNING: Always wear proper personal hearing protection that conforms to AS/NZS1270 during use. Under some conditions and duration of use, noise from this product may contribute to hearing loss.

- The label on your tool may include the following symbols. The symbols and their definitions are as follows:

V.....volts	A.....amperes
Hz.....hertz	W.....watts
min.....minutes	~ or AC.....alternating current
== or DC.....direct current	⎓ or AC/DC.....alternating or direct current
Ⓛ.....Class I Construction (grounded)	no.....no load speed
Ⓚ.....Class II Construction (double insulated)	n.....rated speed
.../min.....per minute	Ⓧ.....earthing terminal
BPM.....beats per minute	⚠.....safety alert symbol
RPM.....revolutions per minute	IPM.....impacts per minute
sfpm.....surface feet per minute	SPM.....strokes per minute

SAVE ALL WARNINGS AND INSTRUCTIONS FOR FUTURE REFERENCE

COMPONENTS (FIG. 1)

⚠ WARNING: Never modify the power tool or any part of it. Damage or personal injury could result.

- On/Off-switch
- Lock button
- Shavings discharge outlet
- Planing depth adjustment knob
- Planing depth graduation
- Parallel fence tightening bolt
- Hole for parallel fence
- Side guard
- Motor cover
- Drive belt cover
- Parking foot
- Parallel fence

INTENDED USE

This heavy-duty planer is designed for professional planing of wood.

DO NOT use under wet conditions or in presence of flammable liquids or gases.

This heavy-duty planer is a professional power tool. **DO NOT** let children come into contact with the tool. Supervision is required when inexperienced operators use this tool.

FIG. 1

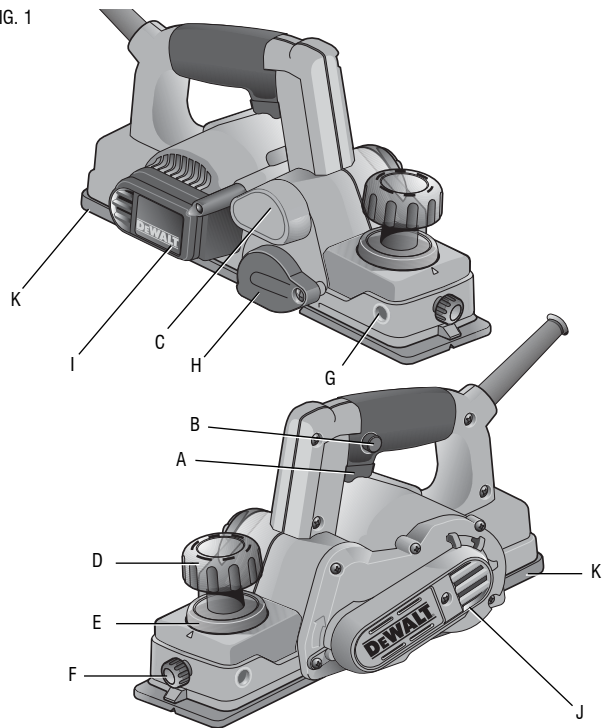

ASSEMBLY AND ADJUSTMENTS

⚠ WARNING: To reduce the risk of serious personal injury, turn tool off and disconnect tool from power source before making any adjustments or removing/installing attachments or accessories. An accidental start-up can cause injury.

Adjusting the Depth of Cut (Fig. 2)

Turn the planing depth adjustment knob (D).

One revolution of the adjustment knob equals a 1.5 mm change in depth. Each click of the adjustment knob represents 0.1 mm of depth, and will increase up to 1.0 mm in depth.

FIG. 2

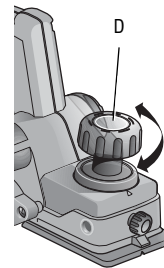
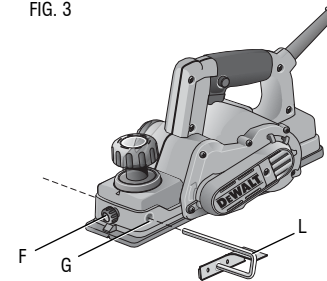

FIG. 3



Attaching and Removing the Parallel Fence (Fig. 3)

The parallel fence (L) is used for optimum tool control on narrow workpieces.

1. Loosen the wing parallel fence tightening bolt (F).
2. Fit the parallel fence (L) into hole (G) from either side.
3. Tighten the parallel fence tightening bolt.
4. To remove the parallel fence, proceed in reverse order.

Removing the Blades (Fig. 4)

1. Remove the three bolts (M) with the spanner (N) supplied.
2. Push the side guard (H) up.
3. Remove drum cover (Q) and remove the blade (O) from its holder.
4. Sharpen or replace the blades. To sharpen blades, see **Sharpen Blades**.

NOTICE: Risk of property damage. Always replace both blades.

5. Replace the drum cover (Q). Make sure the blade is flush with the planing shoe (P).
6. Tighten the three bolts (M).

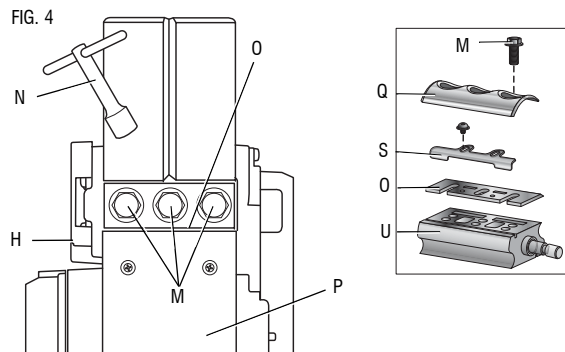

Adjusting Blades (Fig. 5)

1. Place the blade (O) on the gauge (R), and make sure the blade edge is perfectly flush with the inside edge of the gauge (R).
2. Place the bracket (S) on the blade, and make sure the flange of bracket is flush with the back side of the gauge.
3. Tighten the two screws (T) on the bracket.
4. Place the flange of the bracket into the groove of drum (U).
5. Replace the drum cover (Q) and tighten the three bolts (M).

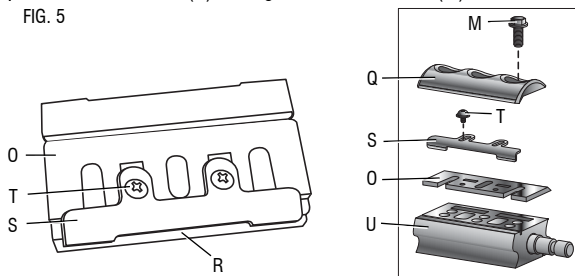

Sharpening Blades (Fig. 6)

1. Fasten the blade to the sharpening holder (V). Make sure both blade edges are facing the same direction.
2. Place the blade edges so they rest flat on the grinding stone.
3. Firmly grip the sharpening holder and move it back and forward to sharpen the blade (O).

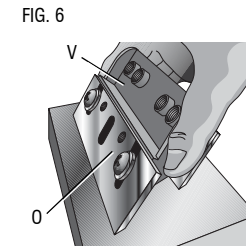

OPERATION

⚠ WARNING: To reduce the risk of serious personal injury, turn tool off and disconnect tool from power source before making any adjustments or removing/installing attachments or accessories. An accidental start-up can cause injury.

NOTICE: Risk of property damage. Use sharp blades only.

PRIOR TO OPERATION:

- Adjust the depth of cut.
- Fit and adjust the parallel fence, if needed.

Switch (Fig. 1)

⚠ WARNING: Check that the tool is not locked on before connecting it to a power supply. If the trigger switch is locked on when the tool is connected to the power supply, it will start immediately. Damage to your tool or personal injury may result.

⚠ CAUTION: Risk of property damage. Allow the tool to reach full speed before touching tool to the work surface. Lift the tool from the work surface before turning the tool off.

To start the planer depress the trigger switch (A). To turn the planer off, release the trigger switch.

LOCK-ON BUTTON

The tool can be locked on for continuous use. To lock the tool ON depress the trigger switch (A) and push in the lock-on button (B). Hold the lock-on button in as you gently release the trigger switch. The tool will continue to run.

To turn the tool off from a locked-on position, squeeze and release the trigger once.

Planing (Fig. 1, 7)

⚠ CAUTION: Risk of property damage. Allow the tool to reach full speed before touching tool to the work surface. Lift the tool from the work surface before turning the tool off.

Hold the planer in the correct position with one hand on the front handle and the other on the auxiliary handle, as shown in Figure 7.

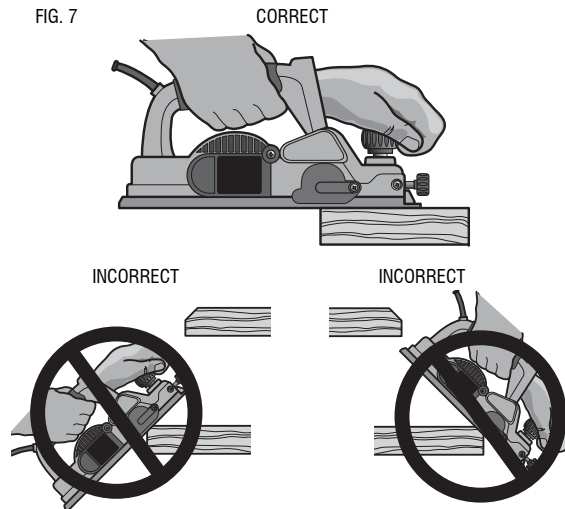

Place the front of the shoe on the surface to be planed, making certain that the cutting blades are not touching the surface. Push down firmly on the front handle of the planer so that the front shoe is **ABSOLUTELY FLAT** on the work surface. Turn the tool on and allow the motor to reach full speed before touching the planer blades to the work surface.

Move the tool slowly into the work and maintain downward pressure to keep the planer flat. Be particularly careful to keep the tool flat at the beginning and the end of the work surface.

Planing Tip: For a smoother appearance, fasten a piece of scrap wood to the end of the piece you are planing. Don't stop planing until the cutting blades of the planer are past your work piece and into the scrap material.

Parking Foot (Fig. 1)

Your planer is equipped with a parking foot (K) that automatically lowers into place when the tool is lifted from the work surface. When planing, the parking foot raises as the tool is pushed forward. When the parking foot is lowered, the planer can set on the work surface without the blade touching.

⚠ CAUTION: Do not lock the trigger switch on and engage the parking foot. The vibration of the running motor will cause the planer to move, possibly falling from the work piece.

MAINTENANCE

⚠ WARNING: To reduce the risk of serious personal injury, turn tool off and disconnect tool from power source before making any adjustments or removing/installing attachments or accessories. An accidental start-up can cause injury.

Lubrication

Your power tool requires no additional lubrication.

Cleaning

⚠ WARNING: Blow dirt and dust out of all air vents with clean, dry air at least once a week. To minimize the risk of eye injury, always wear AS/NZS1337 approved eye protection when performing this.

⚠ WARNING: Never use solvents or other harsh chemicals for cleaning the non-metallic parts of the tool. These chemicals may weaken the plastic materials used in these parts. Use a cloth dampened only with water and mild soap. Never let any liquid get inside the tool; never immerse any part of the tool into a liquid.

Repairs

To assure product SAFETY and RELIABILITY, repairs, maintenance and adjustment (including brush inspection and replacement) should be performed by certified service centers or other qualified service organizations, always using identical replacement parts.

Accessories

▲ WARNING: Since accessories, other than those offered by DEWALT, have not been tested with this product, use of such accessories with this tool could be hazardous. To reduce the risk of injury, only DEWALT recommended accessories should be used with this product.

Recommended accessories for use with your tool are available at extra cost from your local service center. If you need any assistance in locating any accessory, please contact Stanley Black & Decker, 82 Taryn Drive, Epping, VIC 3076 Australia or call 1800 338 002 or (NZ) 0800 339 258.

Stanley Black & Decker
82 Taryn Drive, Epping, VIC 3076 Australia • 1800 338 002 (Aust) or 0800 339 258 (NZ)
www.dewalt.com.au • www.dewalt.co.nz
(APR14) Part No. N396019 D26676-XE Copyright © 2009, 2014 DeWALT

The following are trademarks for one or more DeWALT power tools: the yellow and black color scheme; the "D" shaped air intake grill; the array of pyramids on the handgrip; the kit box configuration; and the array of lozenge-shaped humps on the surface of the tool.

Free Manuals Download Website

<http://myh66.com>

<http://usermanuals.us>

<http://www.somanuals.com>

<http://www.4manuals.cc>

<http://www.manual-lib.com>

<http://www.404manual.com>

<http://www.luxmanual.com>

<http://aubethermostatmanual.com>

Golf course search by state

<http://golfingnear.com>

Email search by domain

<http://emailbydomain.com>

Auto manuals search

<http://auto.somanuals.com>

TV manuals search

<http://tv.somanuals.com>