

# President<sup>®</sup> 4-Ball Pumps

3A1450D

EN

**Air-powered pumps for low pressure, high volume circulation of finishing materials. Do not use for flushing or purging lines with caustics, acids, abrasive line strippers, and other similar fluids. For professional use only.**



### Important Safety Instructions

Read all warnings and instructions in this manual. Save these instructions.

See page 2 for model information, including maximum working pressure.

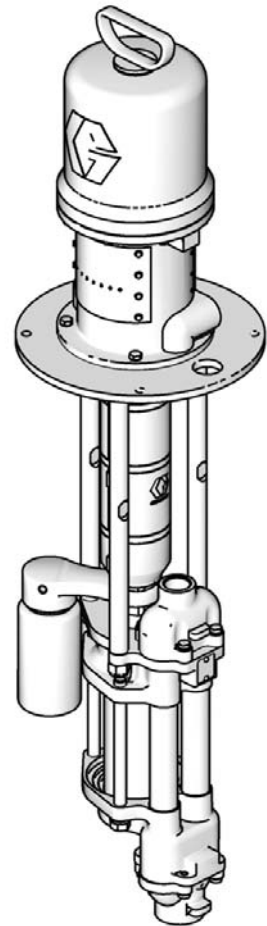

T116614a



PROVEN QUALITY. LEADING TECHNOLOGY.

# Contents

<b>Models</b> .....	<b>2</b>	<b>Maintenance</b> .....	<b>9</b>
<b>Related Manuals</b> .....	<b>2</b>	Preventive Maintenance Schedule .....	9
<b>Warnings</b> .....	<b>3</b>	Flushing .....	9
<b>Installation</b> .....	<b>5</b>	Air Line Filter .....	9
Grounding .....	5	Mix Tank Volume .....	9
Stand Mount .....	5	Stall Test .....	9
Wall Mount .....	5	Changing the TSL .....	10
Plumbing .....	6	<b>Troubleshooting</b> .....	<b>11</b>
Flush Before Using Equipment .....	6	<b>Repair</b> .....	<b>12</b>
Accessories .....	6	Disassembly .....	12
<b>Operation</b> .....	<b>8</b>	Reassembly .....	12
Pressure Relief Procedure .....	8	Reassemble the Coupling Adapter and	
Prime the Pump .....	8	Tie Rods to the Motor .....	13
Stop the Pump at the Bottom of Its Stroke .....	8	<b>Parts</b> .....	<b>15</b>
Shutdown .....	8	<b>Dimensions</b> .....	<b>16</b>
		<b>Mounting Hole Layouts</b> .....	<b>17</b>
		<b>Performance Charts</b> .....	<b>18</b>
		<b>Technical Data</b> .....	<b>19</b>
		<b>Graco Standard Warranty</b> .....	<b>20</b>
		<b>Graco Information</b> .....	<b>20</b>

# Models



Model No.	Series	Pump Length	Maximum Fluid Working Pressure psi (MPa, bar)	Maximum Air Inlet Pressure psi (MPa, bar)	Ratio	Lower Size	Connection Style	Material
24H627	A	standard	460 (3.2, 32.0)	150 (1.0, 10)	3:1	750cc	npt	cst
24H628	A	standard	460 (3.2, 32.0)	150 (1.0, 10)	3:1	750cc	npt	sst
24H629	A	standard	460 (3.2, 32.0)	180 (1.2, 12)	2:1	1000cc	npt	sst
24H997	A	standard	460 (3.2, 32.0)	180 (1.2, 12)	2:1	1000cc	npt	cst
24J074	A	stubby	460 (3.2, 32.0)	150 (1.0, 10)	3:1	750cc	npt	cst
24J075	A	stubby	460 (3.2, 32.0)	150 (1.0, 10)	3:1	750cc	npt	sst

# Related Manuals

Part No.	Description
306982	President Air Motor manual
3A0539	4-Ball Lower manual

# Warnings

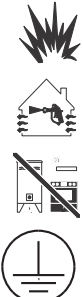
The following warnings are for the setup, use, grounding, maintenance, and repair of this equipment. The exclamation point symbol alerts you to a general warning and the hazard symbols refer to procedure-specific risks. When these symbols appear in the body of this manual, refer back to these Warnings. Product-specific hazard symbols and warnings not covered in this section may appear throughout the body of this manual where applicable.

 <b>WARNING</b>	
	<p><b>FIRE AND EXPLOSION HAZARD</b></p> <p>Flammable fumes, such as solvent and paint fumes, in <b>work area</b> can ignite or explode. To help prevent fire and explosion:</p> <ul style="list-style-type: none"> <li>• Use equipment only in well ventilated area.</li> <li>• Eliminate all ignition sources; such as pilot lights, cigarettes, portable electric lamps, and plastic drop cloths (potential static arc).</li> <li>• Keep work area free of debris, including solvent, rags and gasoline.</li> <li>• Do not plug or unplug power cords, or turn power or light switches on or off when flammable fumes are present.</li> <li>• Ground all equipment in the work area. See <b>Grounding</b> instructions.</li> <li>• Use only grounded hoses.</li> <li>• Hold gun firmly to side of grounded pail when triggering into pail.</li> <li>• If there is static sparking or you feel a shock, <b>stop operation immediately</b>. Do not use equipment until you identify and correct the problem.</li> <li>• Keep a working fire extinguisher in the work area.</li> </ul> <p>Static charge may build up on plastic parts during cleaning and could discharge and ignite flammable vapors. To help prevent fire and explosion:</p> <ul style="list-style-type: none"> <li>• Clean plastic parts only in a well ventilated area.</li> <li>• Do not clean with a dry cloth.</li> <li>• Do not operate electrostatic guns in equipment work area.</li> </ul>
	<p><b>PRESSURIZED EQUIPMENT HAZARD</b></p> <p>Fluid from the gun/dispense valve, leaks, or ruptured components can splash in the eyes or on skin and cause serious injury.</p> <ul style="list-style-type: none"> <li>• Follow the <b>Pressure Relief Procedure</b> when you stop spraying and before cleaning, checking, or servicing equipment.</li> <li>• Tighten all fluid connections before operating the equipment.</li> <li>• Check hoses, tubes, and couplings daily. Replace worn or damaged parts immediately.</li> </ul>
	<p><b>TOXIC FLUID OR FUMES HAZARD</b></p> <p>Toxic fluids or fumes can cause serious injury or death if splashed in the eyes or on skin, inhaled, or swallowed.</p> <ul style="list-style-type: none"> <li>• Read MSDSs to know the specific hazards of the fluids you are using.</li> <li>• Store hazardous fluid in approved containers, and dispose of it according to applicable guidelines.</li> </ul>

# ! WARNING



## PERSONAL PROTECTIVE EQUIPMENT

You must wear appropriate protective equipment when operating, servicing, or when in the operating area of the equipment to help protect you from serious injury, including eye injury, hearing loss, inhalation of toxic fumes, and burns. This equipment includes but is not limited to:

- Protective eyewear, and hearing protection.
- Respirators, protective clothing, and gloves as recommended by the fluid and solvent manufacturer.



## EQUIPMENT MISUSE HAZARD

Misuse can cause death or serious injury.

- Do not operate the unit when fatigued or under the influence of drugs or alcohol.
- Do not exceed the maximum working pressure or temperature rating of the lowest rated system component. See **Technical Data** in all equipment manuals.
- Use fluids and solvents that are compatible with equipment wetted parts. See **Technical Data** in all equipment manuals. Read fluid and solvent manufacturer's warnings. For complete information about your material, request MSDS from distributor or retailer.
- Do not leave the work area while equipment is energized or under pressure. Turn off all equipment and follow the **Pressure Relief Procedure** when equipment is not in use.
- Check equipment daily. Repair or replace worn or damaged parts immediately with genuine manufacturer's replacement parts only.
- Do not alter or modify equipment.
- Use equipment only for its intended purpose. Call your distributor for information.
- Route hoses and cables away from traffic areas, sharp edges, moving parts, and hot surfaces.
- Do not kink or over bend hoses or use hoses to pull equipment.
- Keep children and animals away from work area.
- Comply with all applicable safety regulations.



## MOVING PARTS HAZARD

Moving parts can pinch, cut or amputate fingers and other body parts.

- Keep clear of moving parts.
- Do not operate equipment with protective guards or covers removed.
- Pressurized equipment can start without warning. Before checking, moving, or servicing equipment, follow the **Pressure Relief Procedure** and disconnect all power sources.



# Installation

## Grounding

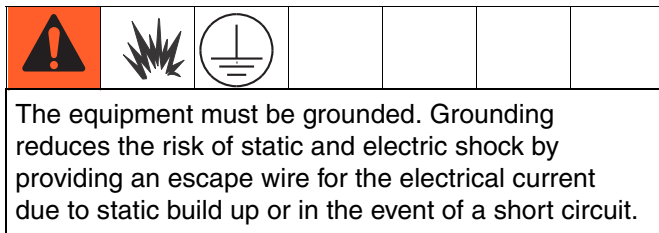

**Pump:** use a ground wire and clamp (Y). See FIG. 1. Loosen the grounding lug locknut (W) and washer. Insert one end of the ground wire into the slot in the lug and tighten the locknut securely. Connect the ground clamp to a true earth ground. Order Part No. 237569, Ground Wire and Clamp.

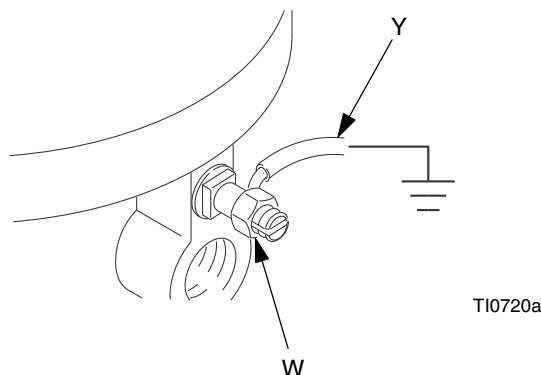

**FIG. 1. Ground Wire**

**Air and fluid hoses:** use only electrically conductive hoses with a maximum of 500 ft. (150 m) combined hose length to ensure grounding continuity. Check the electrical resistance of hoses. If total resistance to ground exceeds 25 megohms, replace hose immediately.

**Air compressor:** follow manufacturer's recommendations.

**Surge tank:** use a ground wire and clamp.

**Dispense valve:** ground through a connection to a properly grounded fluid hose and pump.

**Fluid supply container:** follow local code.

**Object being sprayed:** follow local code.

**Solvent pails used when flushing:** follow local code. Use only conductive metal pails, placed on a grounded surface. Do not place the pail on a nonconductive surface, such as paper or cardboard, which interrupts grounding continuity.

**To maintain grounding continuity when flushing or relieving pressure:** hold metal part of the spray gun firmly to the side of a grounded metal pail, then trigger the gun.

## Stand Mount

Order Part No. 253692 Pump Stand Kit (accessory). Mount the pump in the pump stand and secure with the four screws and lockwashers supplied in the kit.

See **Mounting Hole Layouts** on page 17. Secure the stand to the floor with M19 (5/8 in.) bolts which engage at least 152 mm (6 in.) into the concrete floor to prevent the pump from tipping.

## Wall Mount

Order Part No. 255143 Wall Bracket Kit (accessory).

1. Ensure the wall is strong enough to support the weight of the pump assembly and accessories, fluid, hoses, and stress caused during pump operation.
2. Ensure that the mounting location has sufficient clearance for easy operator access.
3. Position the wall bracket at a convenient height, ensuring that there is sufficient clearance for the fluid suction line and for servicing the lower.
4. Drill four 7/16 in. (11 mm) holes using the bracket as a template. Use either of the two mounting hole groupings in the bracket. See **Mounting Hole Layouts**, page 17.
5. Bolt the bracket securely to the wall using bolts and washers designed to hold in the wall's construction.
6. Attach the pump assembly to the mounting bracket.
7. Connect air and fluid hoses.

## Plumbing

See FIG. 2. Install a fluid shutoff valve (D) between the mix tank (A) and the pump.

When using a stainless steel pump, use stainless steel plumbing to maintain a corrosion-resistant system.

## Flush Before Using Equipment

The equipment was tested with lightweight oil, which is left in the fluid passages to protect parts. To avoid contaminating your fluid with oil, flush the equipment with a compatible solvent before using the equipment. See **Flushing**, page 9.

## Accessories

Install the following accessories in the order shown in FIG. 2, using adapters as necessary.

### Air Line

- **Bleed-type master air valve (M):** required in your system to relieve air trapped between it and the air motor when the valve is closed.

<p>Trapped air can cause the pump to cycle unexpectedly, which could result in serious injury from splashing or moving parts. Be sure the valve is easily accessible from the pump and located downstream from the air regulator. Be sure the air bleed hole points away from the operator.</p>						

<p>To help prevent fluid overpressurization, do not exceed the maximum air inlet pressure rating to the air motor (see page 2). If you can apply more than the maximum air input pressure to the system, install a safety relief valve between the bleed-type master air valve and the air motor. The safety relief valve must be set to open if the air inlet pressure to the motor exceeds the motor rating.</p>						

- **Pump air regulator (L):** to control pump speed and outlet pressure. Locate close to the pump.
- **Air line filter (K):** removes harmful dirt and moisture from compressed air supply.
- **Second bleed-type air valve (H):** isolates air line accessories for servicing. Locate upstream from all other air line accessories.

### Fluid Line

- **Fluid filter:** with a 60 mesh (250 micron) stainless steel element to filter particles from the fluid as it leaves the pump.
- **Fluid drain valve (N):** required in your system, to relieve fluid pressure in the hose and gun.
- **Fluid shutoff valve (D):** shuts off fluid flow.



# Operation

## Pressure Relief Procedure



1. Close the bleed-type master air valve (M).
2. Open the dispensing valve, if used.
3. Open all fluid drain valves (N) in the system, having a waste container ready to catch drainage. Leave drain valve(s) open until you are ready to pump again.

## Prime the Pump

1. Fill the TSL reservoir to the Maximum fill line with Throat Seal Liquid (TSL). See FIG. 3 on page 10.

**NOTE:** During operation the TSL level in the reservoir will fluctuate slightly at pump changeover.

2. Close pump air regulator (L) by turning knob counterclockwise reducing pressure to zero. Close bleed-type air valve (M). Also verify that all drain valves (N) are closed.
3. Connect air line (J) to bleed type air valve (M).
4. Check that all fittings throughout system are tightened securely.
5. Connect the fluid supply line (C) from the mix tank shutoff valve (D) to the pump.
6. Connect the fluid line (E) to the pump outlet.
7. Open bleed-type air valve (M). Slowly turn pump air regulator (L) clockwise, increasing pressure until pump starts.
8. Cycle pump slowly until all air is pushed out and pump and hoses are fully primed.

9. Verify that pump actuations are priming the pump wet-cup. If not, confirm that the TSL pump piston is being depressed at bottom changeover, and that reservoir check valves are not stuck closed.

10. Close the fluid shutoff valve (D) downstream of the pump. The pump should stall against pressure.

**NOTE:** In a circulation system, the pump operates continuously until the power supply is shut off. In a direct-supply system, the pump starts when the dispense valve is opened, and stops when the dispense valve is closed.

## Stop the Pump at the Bottom of Its Stroke



Relieve the pressure when you stop the pump for any reason. Stop the pump on the downstroke, before the air motor changes over.

### NOTICE

Failure to stop the pump at the bottom of its stroke allows fluid to dry on the piston rod, which can damage the throat packings and the TSL pump piston seal when the pump is restarted.

## Shutdown



Follow **Pressure Relief Procedure**, page 8.

Always flush the pump before the fluid dries on the displacement rod. See **Flushing** on page 9.



# Maintenance

## Preventive Maintenance Schedule

The operating conditions of your particular system determine how often maintenance is required. Establish a preventive maintenance schedule by recording when and what kind of maintenance is needed, and then determine a regular schedule for checking your system. Your maintenance schedule should include the following:

## Flushing

- Flush before changing colors, before fluid can dry in the equipment, at the end of the day, before storing, and before repairing equipment.
- Flush at the lowest pressure possible. Check connectors for leaks and tighten as necessary.
- Flush with a fluid that is compatible with the fluid being dispensed and the equipment wetted parts.

## Air Line Filter

Drain and clean as necessary.

## Mix Tank Volume

Do not let the mix tank run dry. When the tank is empty, the pump demands more power as it tries to suck in some fluid. This causes the pump to run too fast, which can seriously damage the pump.

## Stall Test

Perform a stall test periodically to ensure the piston seal is in good working condition and prevent system over-pressurization:

Close the fluid shutoff valve (D) closest to the pump on the downstroke and be sure that the pump stalls. Open the fluid shutoff valve to restart the pump. Close the fluid shutoff valve (D) closest to the pump on the upstroke and be sure that the pump stalls.

### NOTICE

Do not allow the pump to run quickly for a long period of time as this may damage the packings.

## Changing the TSL

Check the condition of the TSL and the level in the reservoir every week, minimum. TSL should be changed at least every month.

Part No. 206995 Throat Seal Liquid (TSL) carries residue from the pump rod into the reservoir. Discoloration of the TSL fluid is to be expected during normal operation. After some time the TSL will thicken and darken, and must be replaced. Thick, dirty TSL will not pump through the lines and will harden in the pump wet-cup.

How long TSL lasts depends on which chemicals are used, how much is used, what pressure, and condition of the pump seal and rod.

A drop in the level of TSL in the reservoir indicates that the throat packings are starting to wear. Add TSL to the reservoir and keep the level above the Minimum fill line. Monitor the usage and condition of the TSL. If pumped material bypasses the throat packings and enters the TSL reservoir, replace the packings.

To change the TSL:

1. Shut off the pump.



To avoid the buildup of static charge, do not rub the plastic bottle with a dry cloth while it is attached to the pump. Remove the bottle to clean, if needed.

2. Remove and empty the reservoir bottle. Clean any residue.
3. Clean screen (Z) of inlet check valve (VI). If check valves are not sealing and dirty TSL is getting into the wet-cup, replace the check valves (VI, VO). See FIG. 3.
4. Fill the reservoir to the Maximum fill line with Throat Seal Liquid (TSL).
5. Run pump. Each time pump rod reaches bottom of stroke, check that some TSL is pumped from reservoir through wet-cup and back to reservoir.

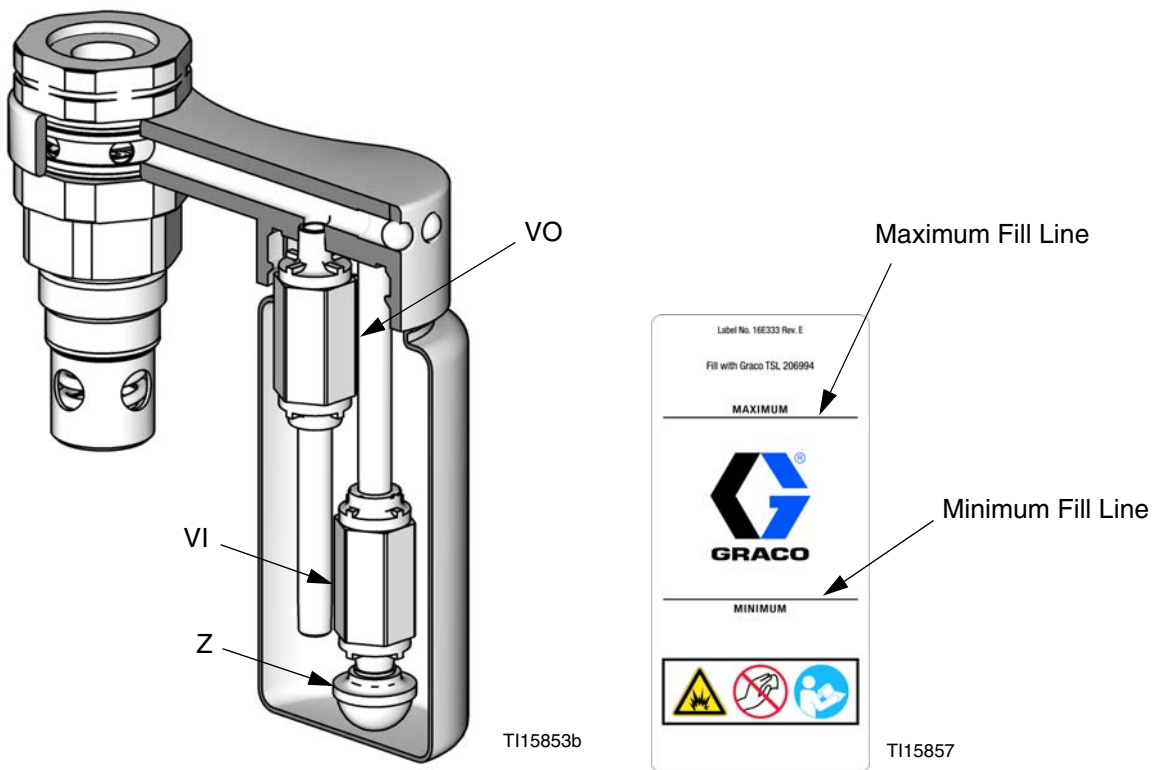

FIG. 3. Cutaway of TSL Reservoir, and Fill Lines

# Troubleshooting

Problem	Cause	Solution
Pump output low on both strokes.	Restricted air supply lines.	Clear any obstructions; be sure all shutoff valves are open; increase pressure, but do not exceed maximum working pressure.
	Exhausted fluid supply.	Refill and reprime pump.
	Clogged fluid outlet line, valves, etc.	Clear.
	Worn piston packing.	Replace. See lower manual.
Pump output low on only one stroke.	Held open or worn ball check valves.	Check and repair.
	Worn piston packings.	Replace. See lower manual.
No output.	Improperly installed ball check valves.	Check and repair.
Pump operates erratically.	Exhausted fluid supply.	Refill and reprime pump.
	Held open or worn ball check valves.	Check and repair.
	Worn piston packing.	Replace. See lower manual.
Pump will not operate.	Restricted air supply lines.	Clear any obstructions; be sure all shut off valves are open; increase pressure, but do not exceed maximum working pressure.
	Exhausted fluid supply.	Refill and reprime pump.
	Clogged fluid outlet line, valves, etc.	Clear.
	Damaged air motor.	See air motor manual.
	Fluid dried on piston rod.	Disassemble and clean pump. See lower manual. In future, stop pump at bottom of stroke.
TSL pump not pumping TSL fluid.	Plugged manifold.	Clear the manifold. Verify that the manifold is clear by blowing compressed air through the opening.
	Plugged check valves.	Clear obstruction in check valves.
	Plugged inlet strainer.	Clear strainer mesh.
	Damaged TSL pump piston.	Replace TSL pump piston.

# Repair

## Disassembly



1. Relieve the pressure, see **Pressure Relief Procedure** page 8.
2. Disconnect the hoses from the lower and plug the ends to prevent fluid contamination.
3. See FIG. 4. Remove the 2-piece shield (109) by inserting a screwdriver straight into the slot, and using it as a lever to release the tab. Repeat for all tabs. **Do not** use the screwdriver to pry the shields apart.
4. Loosen the coupling nut (110) and remove the collars (111). Remove the coupling nut from the piston rod (R). Unscrew the locknuts (105) from the tie rods (104). Separate the motor (101) and lower (102). See FIG. 5.
5. To repair the air motor or lower, see the separate manuals listed under **Related Manuals** on page 2.

## Reassembly

**NOTE:** If the coupling adapter (108) and tie rods (104) have been disassembled from the motor, see **Reassemble the Coupling Adapter and Tie Rods to the Motor** on page 13.

1. See FIG. 5. Assemble the coupling nut (110) to the piston rod (R).
2. Orient the lower (102) to the motor (101). Position the lower on the tie rods (104). Lubricate the threads of the tie rods. Screw the tie rod locknuts (105) onto the tie rods. Tighten the locknuts and torque to 50-55 ft-lb (68-75 N•m).
3. Insert the collars (111) into the coupling nut (110). Tighten the coupling nut onto the coupling adapter (108) and torque to 75-80 ft-lb (102-109 N•m).
4. See FIG. 4. Install the shields (109) by engaging the bottom lips with the groove in the wet-cup cap. Snap the two shields together.
5. Flush and test the pump before reinstalling it in the system. Connect hoses and flush the pump. While it is pressurized, check for smooth operation and leaks. Adjust or repair as necessary before reinstalling in the system. Reconnect the pump ground wire before operating.

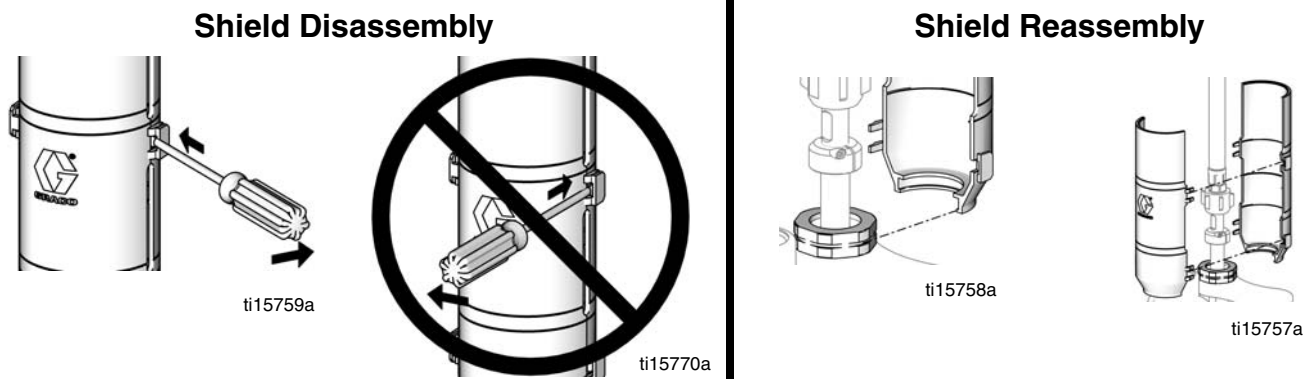
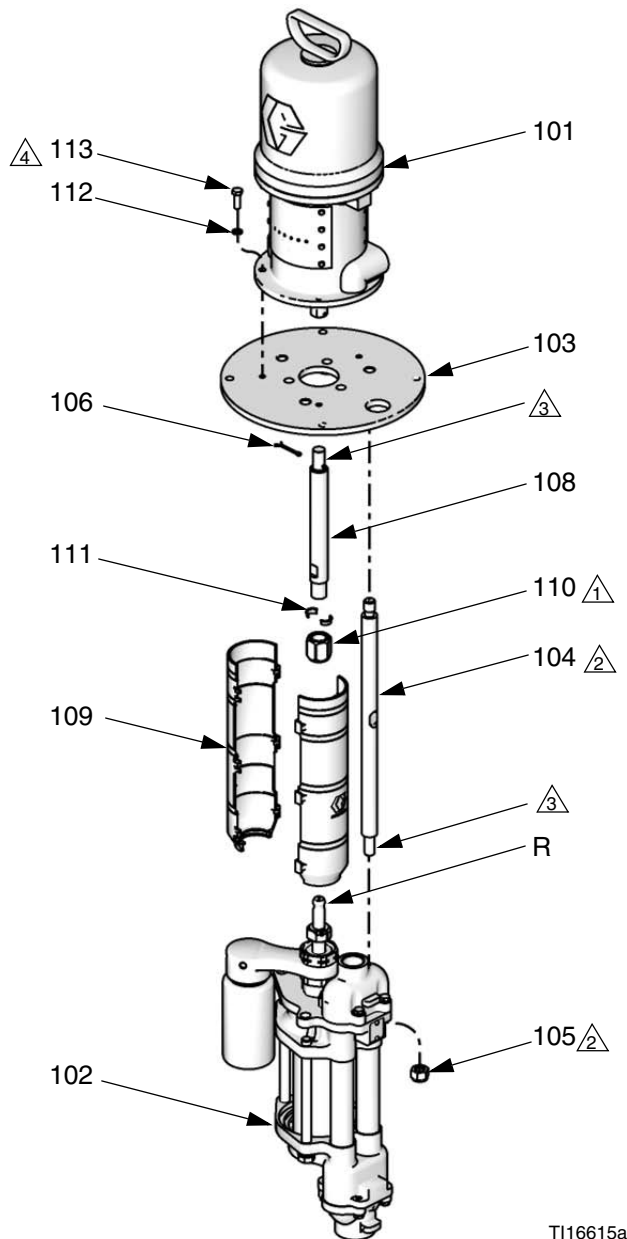

FIG. 4. Disassembly and Reassembly of the Shields

## Reassemble the Coupling Adapter and Tie Rods to the Motor

**NOTE:** Use this procedure only if the coupling adapter (108) and tie rods (104) have been disassembled from the motor, to ensure proper alignment of the motor shaft to the piston rod (R).



TI16615a

1. See FIG. 5. Screw the tie rods (104) into the motor (101) and torque to 50-55 ft-lb (68-75 N•m).
2. Fill the cavity in the bottom of the motor shaft with grease. Lubricate the threads of the coupling adapter (105). Screw the adapter into the motor shaft and install the pin (106).
3. Assemble the coupling nut (110) to the piston rod (R).
4. Orient the lower (102) to the motor (101). Position the lower on the tie rods (104). Lubricate the threads of the tie rods. Screw the tie rod locknuts (105) onto the tie rods. Tighten the locknuts and torque to 50-55 ft-lb (68-75 N•m).
5. Insert the collars (111) into the coupling nut (110). Tighten the coupling nut onto the coupling adapter (108) and torque to 75-80 ft-lb (102-109 N•m).

△1 Torque to 75-80 ft-lb (102-109 N•m).

△2 Torque to 50-55 ft-lb (68-75 N•m).

△3 Apply lubricant.

△4 Torque to 15-17 ft-lb (20-23 N•m).

**FIG. 5. Reassembly**



# Parts

24H627 3:1 Ratio Pump with 750cc CST Lower  
 24H628 3:1 Ratio Pump with 750cc SST Lower  
 24H629 2:1 Ratio Pump with 1000cc SST Lower  
 24H997 2:1 Ratio Pump with 1000cc CST Lower  
 24J074 3:1 Ratio Pump (stubby size) with 750cc CST Lower  
 24J075 3:1 Ratio Pump (stubby size) with 750cc SST Lower

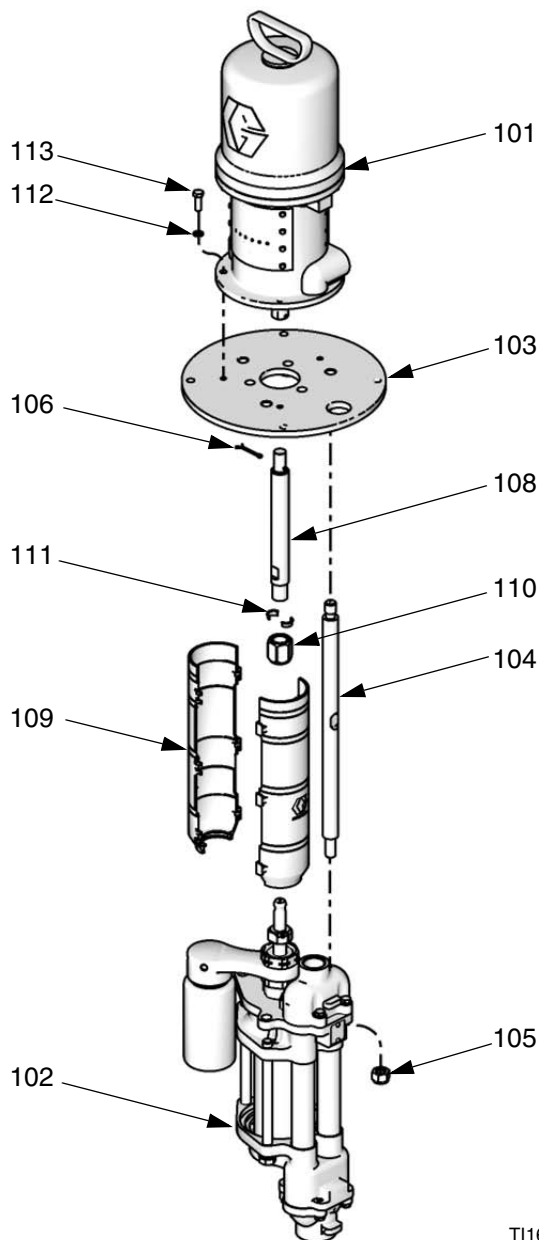

T116615a

Ref. No.	Part No.	Description	Qty.
101	205038	MOTOR, air, President; see manual 306982	1
102		LOWER, 4-Ball, see manual 3A0539	1
	24F420	750cc carbon steel, used on Model 24H627 and 24J074	
	24F413	750cc stainless steel, used on Model 24H628 and 24J075	
	24F424	1000cc stainless steel, used on Model 24H629	
	24F431	1000cc carbon steel, used on Model 24H997	
103	186071	PLATE, adapter	1
104	15G924	TIE ROD, 14.25 in. (362 mm) between shoulders	3
	16H434	TIE ROD, 8.375 in. (213 mm) between shoulders, used on Model 24J074 and 24J075 only	3
105	108683	NUT, lock, hex; 9/16-12 unc	3
106	101946	PIN, cotter; stainless steel	1
108	16C373	ADAPTER, coupling	1
	16H375	ADAPTER, coupling, used on Model 24J074 and 24J075 only	1
109	24F252	SHIELD KIT; includes 2 shields	1
	24A640	SHIELD KIT; includes 2 shields, used on Model 24J074 and 24J075 only	1
110	15T311	NUT, coupling	1
111	184128	COLLAR, coupling	2
112	100214	WASHER, lock	3
113	100450	SCREW, cap, hex hd; 5/16-18 x 1 in. (25 mm)	3

# Dimensions

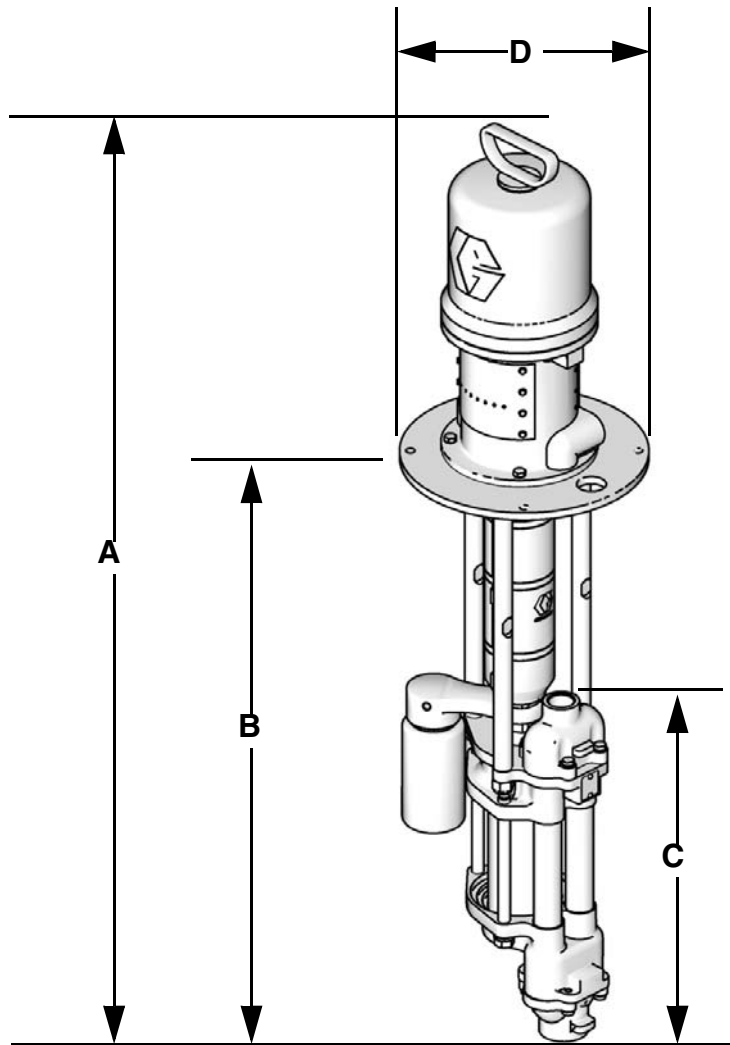

T116614a

Model	Lower Size	A in. (mm)	B in. (mm)	C in. (mm)	D in. (mm)	Approx. Weight lb (kg)
24H627	750cc	46.3 (1176)	29.8 (757)	17.5 (445)	11.5 (292)	73 (33)
24H628	750cc					74 (34)
24H629	1000cc					74 (34)
24H997	1000cc	40.4 (1026)	24.0 (610)			71 (32)
24J074	750cc					71 (32)
24J075	750cc					71 (32)



# Mounting Hole Layouts

**255143 Wall Bracket Accessory**

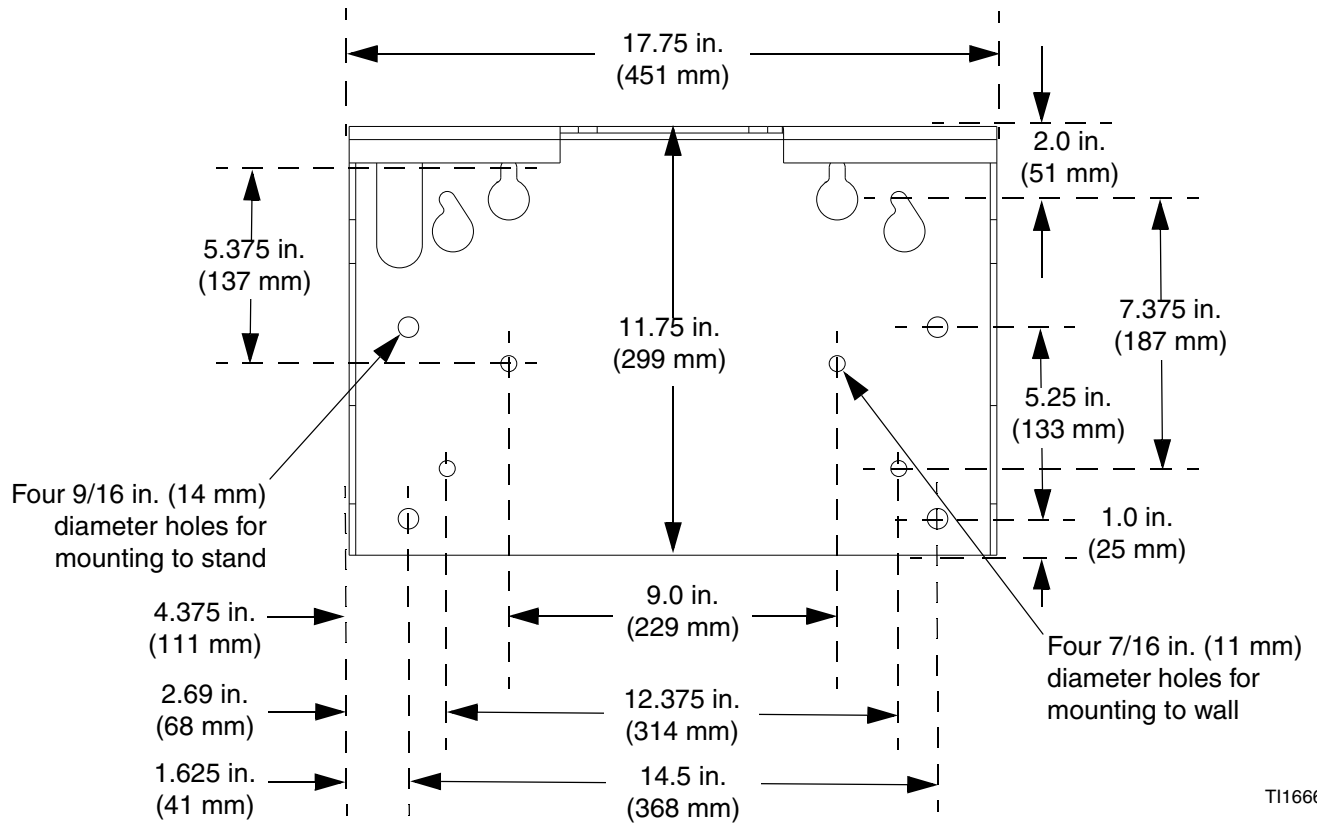

T116666a

**253692 Floor Stand Accessory**

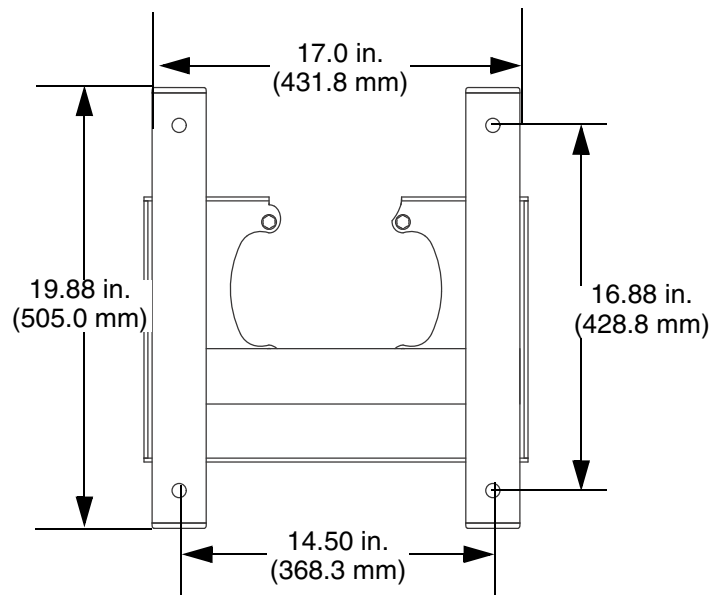

T115859a

# Performance Charts

## Fluid Outlet Pressure

To find fluid outlet pressure (MPa/bar/psi) at a specific flow (lpm/gpm) and operating pressure (A/B/C):

1. Locate desired flow at bottom of chart.
2. Follow vertical line up to intersection with selected operating pressure curve (solid line). Follow left to scale to read fluid outlet pressure.

## Air Consumption

To find air consumption (l/min. or gpm) at a specific fluid flow (l/min. or gpm) and operating pressure (A/B/C):

1. Locate desired flow along bottom of chart.
2. Read vertical line up to intersection with selected air consumption curve (dashed line). Follow left to scale to read air consumption.

### Key

- A** 0.7 MPa, 7 bar (100 psi) air pressure
  - B** 0.5 MPa, 4.9 bar (70 psi) air pressure
  - C** 0.3 MPa, 2.8 bar (40 psi) air pressure
- Test Fluid: No. 10 Weight Oil

### 3:1 President with 750cc Lower

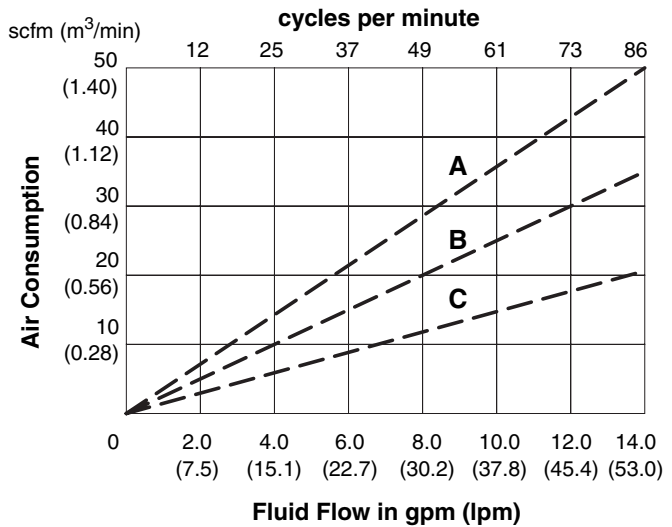
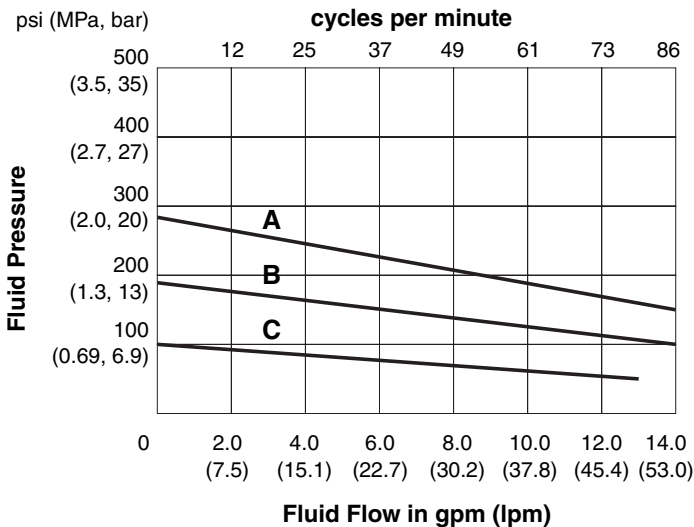

### 2:1 President with 1000cc Lower

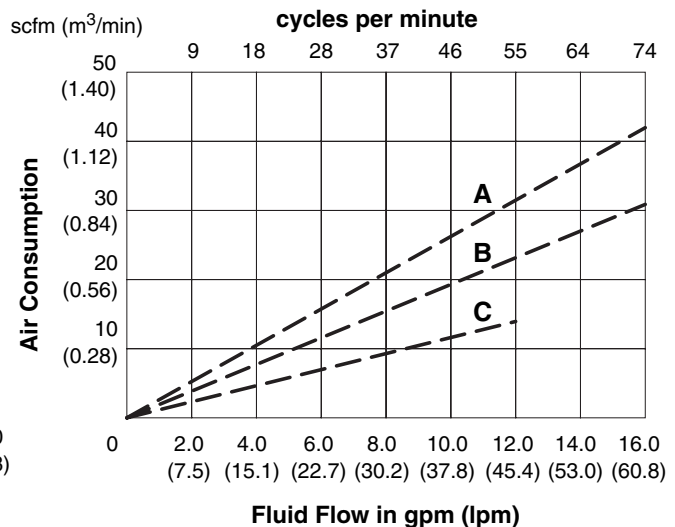
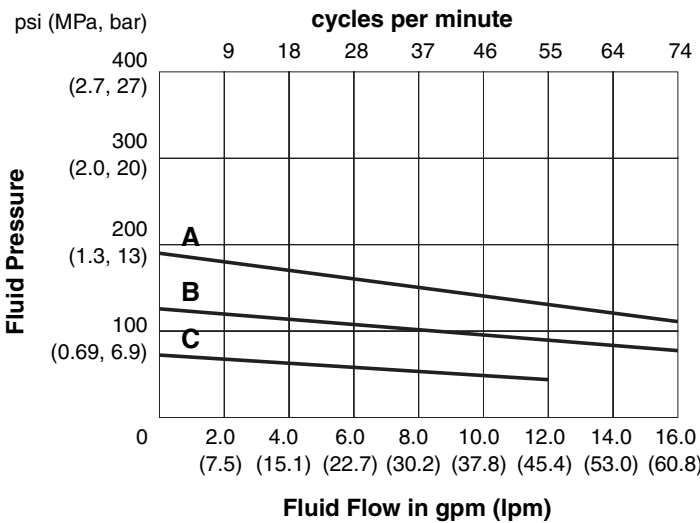

# Technical Data

Model	Maximum Fluid Working Pressure psi (MPa, bar)	Maximum Air Input Pressure psi (MPa, bar)	Air Consumption	Fluid Flow at 60 cycles per minute gpm (lpm)	Output per Cycle gal. (cc)	Maximum Fluid Temperature Rating °F (°C)
24H627	460 (3.2, 32.0)	150 (1.0, 10)	See Performance Charts	9.6 (36.4)	0.16 (610)	150° (66°)
24H628	460 (3.2, 32.0)	150 (1.0, 10)		9.6 (36.4)	0.16 (610)	
24H629	460 (3.2, 32.0)	180 (1.2, 12)		14.1 (53.5)	0.23 (890)	
24H997	460 (3.2, 32.0)	180 (1.2, 12)		14.1 (53.5)	0.23 (890)	
24J074	460 (3.2, 32.0)	150 (1.0, 10)		9.6 (36.4)	0.16 (610)	
24J075	460 (3.2, 32.0)	150 (1.0, 10)		9.6 (36.4)	0.16 (610)	

Air inlet size: 1/2 npt(f)

Fluid inlet size: 1-1/2 npt(f)

Fluid outlet size: 1 npt(f)

Wetted parts: See Lower manual 3A0539.

### Sound Pressure Levels (measured at 1 meter from unit)

Air Motor	Input Air Pressures at 15 cycles per minute		
	40 psi (0.28 MPa, 2.8 bar)	70 psi (0.48 MPa, 4.8 bar)	100 psi (0.7 MPa, 7.0 bar)
President	73.6 dB(A)	78.3 dB(A)	80.9 dB(A)

### Sound Power Levels (tested in accordance with ISO 9614-2)

Air Motor	Input Air Pressures at 15 cycles per minute		
	40 psi (0.28 MPa, 2.8 bar)	70 psi (0.48 MPa, 4.8 bar)	100 psi (0.7 MPa, 7.0 bar)
President	87.4 dB(A)	92.1 dB(A)	94.6 dB(A)

**NOTE:** See President motor manual 306982 for sound data at higher air pressures.

# Graco Standard Warranty

Graco warrants all equipment referenced in this document which is manufactured by Graco and bearing its name to be free from defects in material and workmanship on the date of sale to the original purchaser for use. With the exception of any special, extended, or limited warranty published by Graco, Graco will, for a period of twelve months from the date of sale, repair or replace any part of the equipment determined by Graco to be defective. This warranty applies only when the equipment is installed, operated and maintained in accordance with Graco's written recommendations.

This warranty does not cover, and Graco shall not be liable for general wear and tear, or any malfunction, damage or wear caused by faulty installation, misapplication, abrasion, corrosion, inadequate or improper maintenance, negligence, accident, tampering, or substitution of non-Graco component parts. Nor shall Graco be liable for malfunction, damage or wear caused by the incompatibility of Graco equipment with structures, accessories, equipment or materials not supplied by Graco, or the improper design, manufacture, installation, operation or maintenance of structures, accessories, equipment or materials not supplied by Graco.

This warranty is conditioned upon the prepaid return of the equipment claimed to be defective to an authorized Graco distributor for verification of the claimed defect. If the claimed defect is verified, Graco will repair or replace free of charge any defective parts. The equipment will be returned to the original purchaser transportation prepaid. If inspection of the equipment does not disclose any defect in material or workmanship, repairs will be made at a reasonable charge, which charges may include the costs of parts, labor, and transportation.

**THIS WARRANTY IS EXCLUSIVE, AND IS IN LIEU OF ANY OTHER WARRANTIES, EXPRESS OR IMPLIED, INCLUDING BUT NOT LIMITED TO WARRANTY OF MERCHANTABILITY OR WARRANTY OF FITNESS FOR A PARTICULAR PURPOSE.**

Graco's sole obligation and buyer's sole remedy for any breach of warranty shall be as set forth above. The buyer agrees that no other remedy (including, but not limited to, incidental or consequential damages for lost profits, lost sales, injury to person or property, or any other incidental or consequential loss) shall be available. Any action for breach of warranty must be brought within two (2) years of the date of sale.

**GRACO MAKES NO WARRANTY, AND DISCLAIMS ALL IMPLIED WARRANTIES OF MERCHANTABILITY AND FITNESS FOR A PARTICULAR PURPOSE, IN CONNECTION WITH ACCESSORIES, EQUIPMENT, MATERIALS OR COMPONENTS SOLD BUT NOT MANUFACTURED BY GRACO.** These items sold, but not manufactured by Graco (such as electric motors, switches, hose, etc.), are subject to the warranty, if any, of their manufacturer. Graco will provide purchaser with reasonable assistance in making any claim for breach of these warranties.

In no event will Graco be liable for indirect, incidental, special or consequential damages resulting from Graco supplying equipment hereunder, or the furnishing, performance, or use of any products or other goods sold hereto, whether due to a breach of contract, breach of warranty, the negligence of Graco, or otherwise.

## **FOR GRACO CANADA CUSTOMERS**

The Parties acknowledge that they have required that the present document, as well as all documents, notices and legal proceedings entered into, given or instituted pursuant hereto or relating directly or indirectly hereto, be drawn up in English. Les parties reconnaissent avoir convenu que la rédaction du présente document sera en Anglais, ainsi que tous documents, avis et procédures judiciaires exécutés, donnés ou intentés, à la suite de ou en rapport, directement ou indirectement, avec les procédures concernées.

# Graco Information

For the latest information about Graco products, visit [www.graco.com](http://www.graco.com).

For patent information, see [www.graco.com/patents](http://www.graco.com/patents).

**TO PLACE AN ORDER**, contact your Graco distributor or call to identify the nearest distributor.

**Phone:** 612-623-6921 **or Toll Free:** 1-800-328-0211 **Fax:** 612-378-3505

*All written and visual data contained in this document reflects the latest product information available at the time of publication. Graco reserves the right to make changes at any time without notice.*

Original instructions. This manual contains English. MM 3A1450

**Graco Headquarters:** Minneapolis

**International Offices:** Belgium, China, Japan, Korea

**GRACO INC. AND SUBSIDIARIES • P.O. BOX 1441 • MINNEAPOLIS MN 55440-1441 • USA**

**Copyright 2011, Graco Inc. All Graco manufacturing locations are registered to ISO 9001.**

[www.graco.com](http://www.graco.com)

Revision D, January 2014

## Free Manuals Download Website

<http://myh66.com>

<http://usermanuals.us>

<http://www.somanuals.com>

<http://www.4manuals.cc>

<http://www.manual-lib.com>

<http://www.404manual.com>

<http://www.luxmanual.com>

<http://aubethermostatmanual.com>

Golf course search by state

<http://golfingnear.com>

Email search by domain

<http://emailbydomain.com>

Auto manuals search

<http://auto.somanuals.com>

TV manuals search

<http://tv.somanuals.com>